



sinamics



SINAMICS G110/SINAMICS G120
Inverter chassis units
SINAMICS G120D
Distributed frequency inverters

SIEMENS

Related catalogs

Low-Voltage Motors

IEC Squirrel-Cage Motors
Frame sizes 56 to 450

D 81.1

Order No.:
E86060-K5581-A111-A1-7600

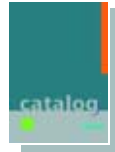

Low-Voltage Motors

IEC Squirrel-Cage Motors
New Generation 1LE1
Frame size 100 to 160

D 81.1
News

Order No.:
E86060-K5581-A121-A1-7600

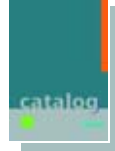

SINAMICS G130

Drive Converter Chassis Units
SINAMICS G150
Drive Converter Cabinet Units

D 11

Order No.:
E86060-K5511-A101-A3-7600

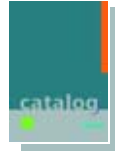

MICROMASTER

MICROMASTER 410/420/430/440
Inverters
0.12 kW to 250 kW

DA 51.2

Order No.:
E86060-K5151-A121-A5-7600

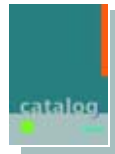

MICROMASTER/COMBIMASTER

MICROMASTER 411 Inverters
COMBIMASTER 411 Distributed
Drive Solutions

DA 51.3

Order No.:
E86060-K5251-A131-A2-7600

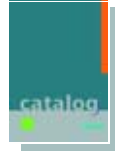

Industrial Communication for Automation and Drives

Part 6: ET 200 Distributed I/O
ET 200S FC Frequency Converter

IK PI

Order No.:
E86060-K6710-A101-B5-7600

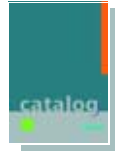

AC NEMA & IEC Motors

Further details available on the
Internet at:

D 81.2
U.S./
Canada

[http://www.sea.siemens.com/
motors](http://www.sea.siemens.com/motors)

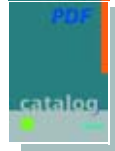

Catalog CA 01

The Offline Mall of Automation and
Drives

CA 01

Order No.:
CD: E86060-D4001-A110-C5-7600
DVD: E86060-D4001-A510-C5-7600



A&D Mall

Internet:
<http://www.siemens.de/automation/mall>



Additional documentation

You will find all information material, such as brochures, catalogs, manuals and operating instructions for standard drive systems up-to-date on the Internet at the address

<http://www.siemens.com/sinamics-g110/printmaterial>

<http://www.siemens.com/sinamics-g120/printmaterial>

<http://www.siemens.com/sinamics-g120d/printmaterial>

You can order the listed documentation or download it in common file formats (PDF, ZIP).

Catalog CA 01 – Selection tool SD configurator

The selection tool **SD configurator** is available in combination with the electronic catalog CA 01.



On CD 2 for the selection and configuring tools, you will find the SD configurators for low-voltage motors, MICROMASTER 4 inverters, SINAMICS G110 inverter chassis units and SIMATIC ET 200S FC frequency converters for distributed I/O, complete with:

- Dimension drawing generator for motors
- Data sheet generator for motors and inverters
- Starting calculation
- 3D models in STP format
- Extensive documentation

Hardware and software requirements

- PC with 500 MHz CPU or faster
- Operating systems
 - Windows 98/ME
 - Windows 2000
 - Windows XP
 - Windows NT 4.0 (Service Pack 6 or higher)
- 256 MB work memory (minimum)
- Screen resolution 1024 x 768, graphic with more than 256 colors, small fonts
- 150 MB spare hard disk space (after installation)
- CD-ROM drive
- Windows-compatible sound card
- Windows-compatible mouse

Installation

You can install this catalog directly from the CD-ROM as a partial version or full version on your hard disk or in the network.

SINAMICS G110/G120 Inverter chassis units

SINAMICS G120D Distributed inverters

Catalog D 11.1 · 2007

Supersedes:
Catalog D 11.1 · 2005
Catalog News D 11.1 N · May 2006

The products contained in this catalog
can also be found in the electronic catalog CA 01
Order No.:
E86060-D4001-A110-C5 -7600 (CD-ROM)
E86060-D4001-A510-C5-7600 (DVD)

Please contact
your local Siemens branch

© Siemens AG 2007



The products and systems described in this catalog are manufactured/distributed under application of a certified quality management system in accordance with DIN EN ISO 9001 (Certified Registration No. DE-000357 QM) and DIN EN ISO 14001 (Certificate Registration No. 0813420 UM and EMS 57390). The certificate is recognized by all IQNet countries.



SIEMENS

Introduction	The SINAMICS drive family The members of the SINAMICS drive family	1
SINAMICS G110 Inverter chassis units 0.12 kW to 3 kW	Overview, Benefits Application Design, Function Technical specifications Dimensional drawings Selection and ordering data Accessories, Starter kit	2
SINAMICS G120 Inverter chassis units 0.37 kW to 90 kW	Overview, Benefits Application Design, Configuration Technical specifications Dimensional drawings Selection and ordering data Components, Accessories	3
SINAMICS G120D Distributed frequency inverter 0.75 kW to 7.5 kW	Overview, Benefits Application Design, Configuration Technical specifications Dimensional drawings Selection and ordering data Accessories	4
Engineering Tools	SD configurator selection aid SIZER configuration tool STARTER drive/commissioning tool Engineering System Drive ES	5
Services and documentation	Training Training case Documentation Replacement fans Service & Support	6
Appendix	Frequency inverters for the distributed I/O ET 200 Siemens contacts worldwide A&D online services Subject index Index of order numbers Terms and conditions of sale and delivery Export regulations	7

Siemens Automation and Drives. Welcome

More than 60,000 people aiming for the same goal: increasing your competitiveness. That's Siemens Automation and Drives.

We offer you a comprehensive portfolio for sustained success in your sector, whether you're talking automation engineering, drives or electrical installation systems. Totally Integrated Automation (TIA) and Totally Integrated Power (TIP) form the core of our offering. TIA and TIP are the basis of our integrated range of products and systems for the manufacturing and process industries as well as building automation. This portfolio is rounded off by innovative services over the entire life cycle of your plants.

Learn for yourself the potential our products and systems offer. And discover how you can permanently increase your productivity with us.

Your regional Siemens contact can provide more information. He or she will be glad to help.



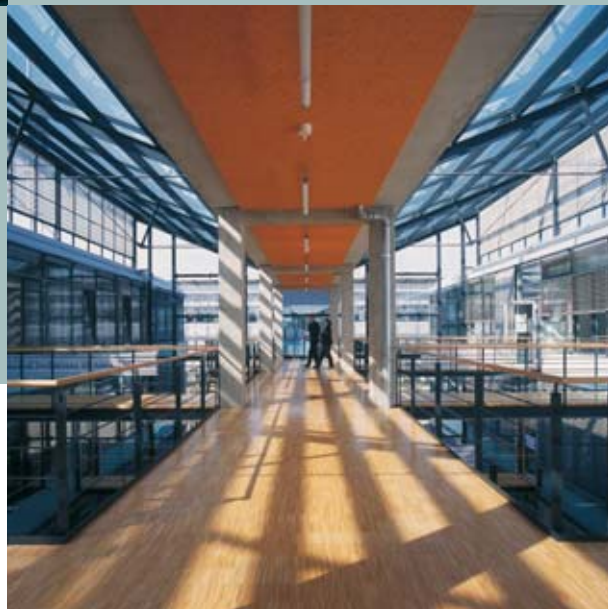

Sharpen your competitive edge. Totally Integrated Automation

With Totally Integrated Automation (TIA), Siemens is the only manufacturer to offer an integrated range of products and systems for automation in all sectors – from incoming goods to outgoing goods, from the field level through the production control level to connection with the corporate management level.

On the basis of TIA, we implement solutions that are perfectly tailored to your specific requirements and are characterized by a unique level of integration. This integration not only ensures significant reductions in interface costs but also guarantees the highest level of transparency across all levels.

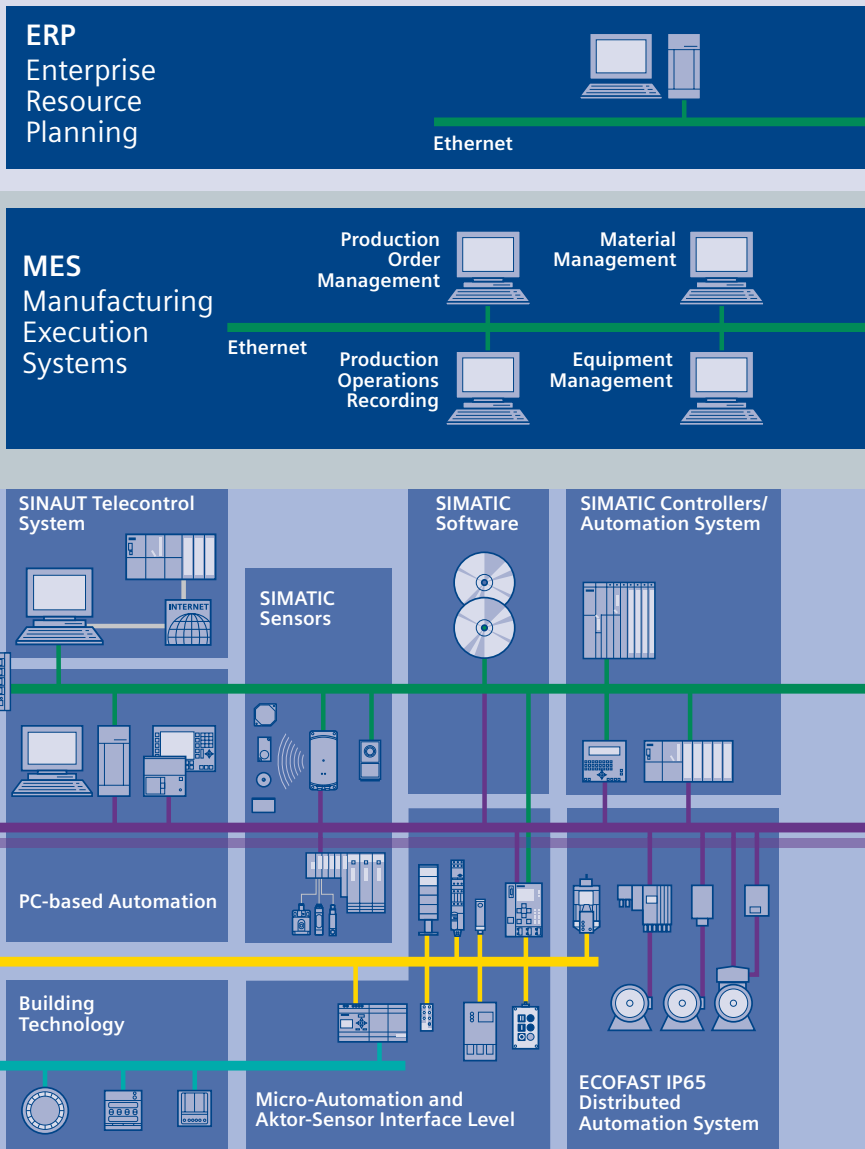

It goes without saying that you profit from Totally Integrated Automation during the entire life cycle of your plants – from the first planning steps, through operation, right up to modernization. Consistent integration in the further development of our products and systems guarantees a high degree of investment security here.

Totally Integrated Automation makes a crucial contribution towards optimizing everything that happens in the plant and thus creates the conditions for a significant increase in productivity.

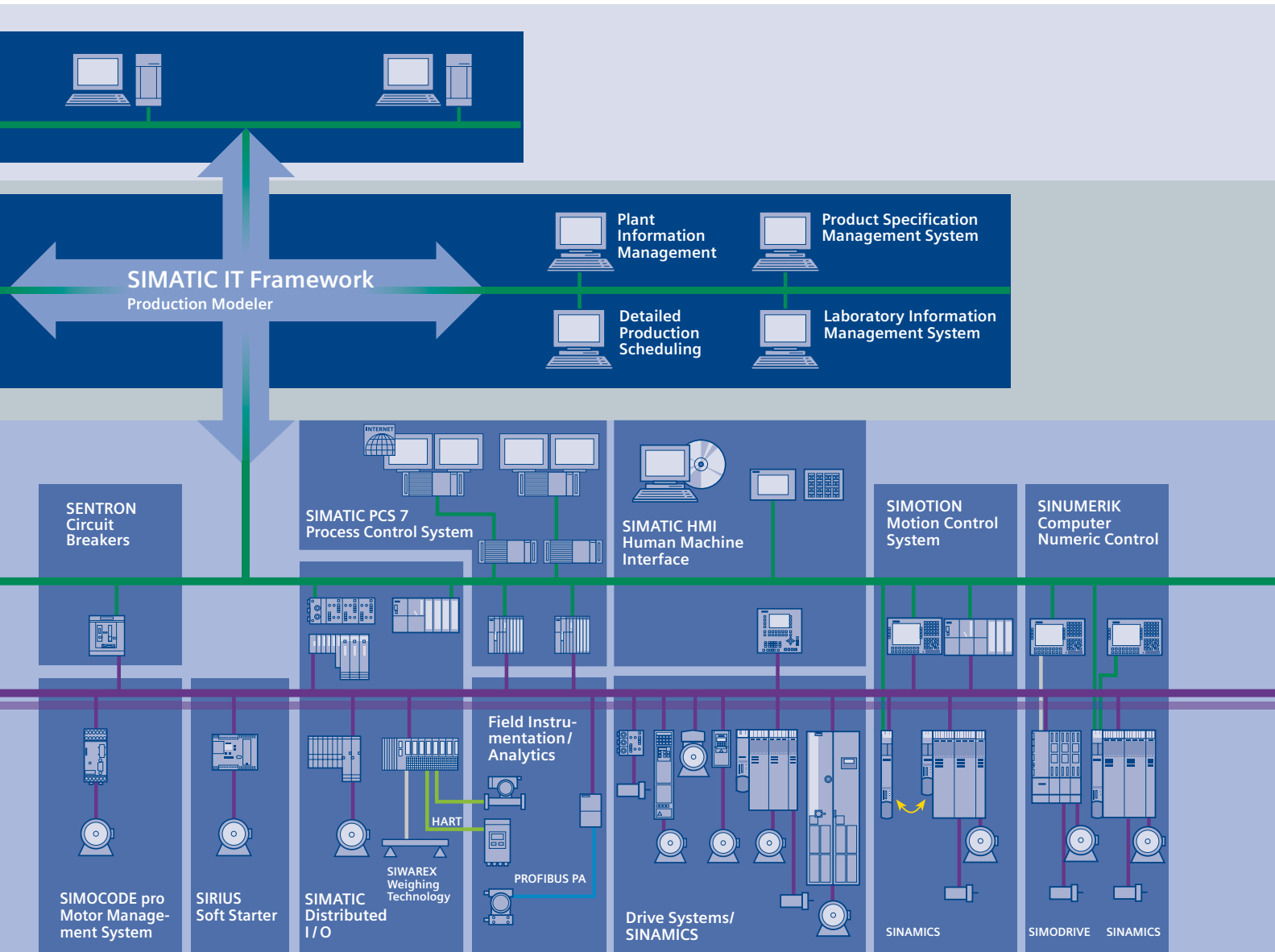

Protecting the environment and resources. Environmental sustainability

Environmental protection will continue to grow in importance as a result of progressive urbanization and global population growth. These global mega-trends make the careful and sustainable handling of natural resources a central challenge.

We are convinced that every individual – and especially every company – has an ecological responsibility. At Siemens Automation and Drives, we stand by this conviction. Our high environmental protection goals are part of our strict environmental management. We investigate the possible effects of our products and systems on the environment right back at the development stage. We concern ourselves, for example, with the question of how to reduce power consumption in plant operation – and we offer appropriate solutions, such as our energy-saving motors that cut power consumption in industrial manufacturing by up to 40% thanks to their high efficiency levels.

Many of our products and systems comply with the EC Directive RoHS (Restriction of Hazardous Substances). All the relevant Siemens AG sites are, of course, certified in accordance with DIN EN ISO 14001.

Our commitment goes well beyond compliance with the relevant directives and legislation: we are an active driving force behind environmental protection, through further development of environmental management systems, for example, and we are involved in professional associations such as the German Electrical and Electronic Manufacturers Association (ZVEI).





Introduction



1/2 The SINAMICS drive family

- 1/2 Applications
- 1/2 Versions
- 1/2 Platform concept
- 1/3 Quality in accordance with DIN EN ISO 9001
- 1/3 Suitable for global use

1/6 The members of the SINAMICS drive family

Low-voltage inverters

- 1/6 SINAMICS G110
- 1/6 SINAMICS G120
- 1/6 SINAMICS G120D
- 1/7 SINAMICS G130/SINAMICS G150
- 1/7 SINAMICS S120
- 1/7 SINAMICS S150

Medium-voltage inverters

- 1/8 SINAMICS GM150
- 1/8 SINAMICS SM150

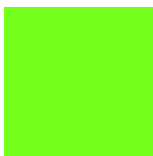

SINAMICS

Introduction

The SINAMICS drive family

SINAMICS G



Mixer/mills

Pumps/fans/
compressors

Conveyor systems



Extrusion



Textiles

Metal forming
technology

Woodworking

SINAMICS S



Rolling mills



Packaging



Machine tools

Printing and paper
machines

Applications of the SINAMICS drive family

Applications

SINAMICS is the new family of Siemens drives designed for machine and plant engineering applications. SINAMICS offers solutions for all drive tasks:

- Simple pump and fan applications in the process industry
- Applied single drives in centrifuges, presses, extruders, elevators, as well as conveyor and transport systems
- Drive line-ups in textile, plastic film, and paper machines, as well as in rolling mill plants
- Highly dynamic servo drives for machine tools, as well as packaging and printing machines

Versions

Depending on the application, the SINAMICS range offers the ideal variant for any drive task.

- SINAMICS G is designed for standard applications with asynchronous (induction) motors. These applications have less stringent requirements regarding the dynamics and accuracy of the motor speed.
- SINAMICS S handles complex drive tasks with synchronous and asynchronous (induction) motors and fulfills stringent requirements regarding
 - dynamics and accuracy,
 - integration of extensive technological functions in the drive control system

Platform concept and Totally Integrated Automation

All SINAMICS versions are based on a platform concept. Common hardware and software components, as well as standardized tools for design, configuration and commissioning tasks, ensure high-level integration across all components. SINAMICS handles a wide variety of drive tasks with no system gaps. The different SINAMICS versions can easily be combined with each other.

SINAMICS is a part of the Siemens "Totally Integrated Automation" concept. Integrated SINAMICS systems covering configuration, data storage and communication at the automation level, ensure low-maintenance solutions with the SIMATIC, SIMOTION and SINUMERIK control systems.

G_D211_EN_00137

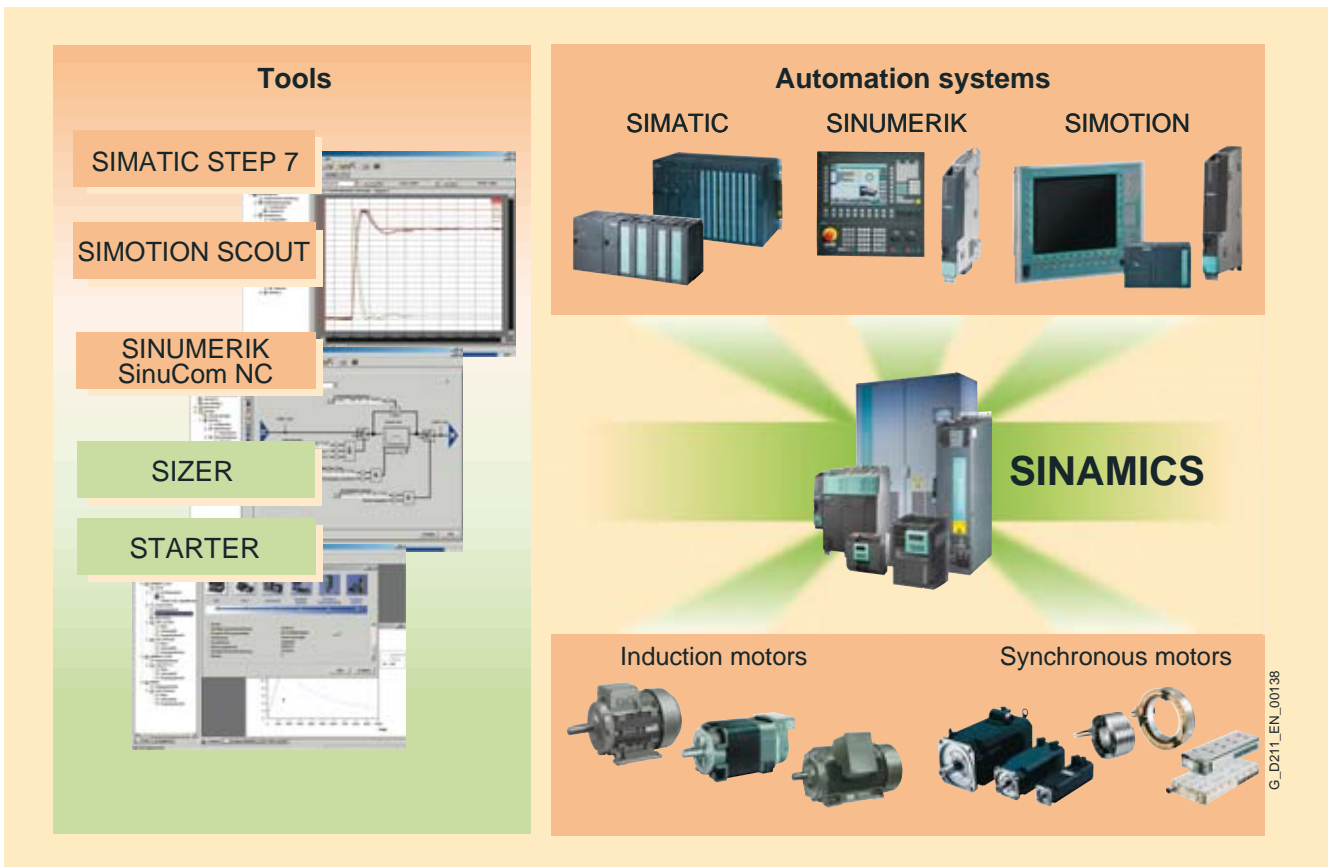

SINAMICS as part of the Siemens modular automation system

Quality in accordance with EN ISO 9001

SINAMICS conforms to the most exacting quality requirements. Comprehensive quality assurance measures in all development and production processes ensure a consistently high level of quality.

Of course, our quality assurance system is certified by an independent authority in accordance with EN ISO 9001.

Suitable for global use

SINAMICS meets the requirements of relevant international standards and regulations – from the EN standards and IEC standards to UL and cULus regulations.

SINAMICS

Introduction

1

The SINAMICS drive family

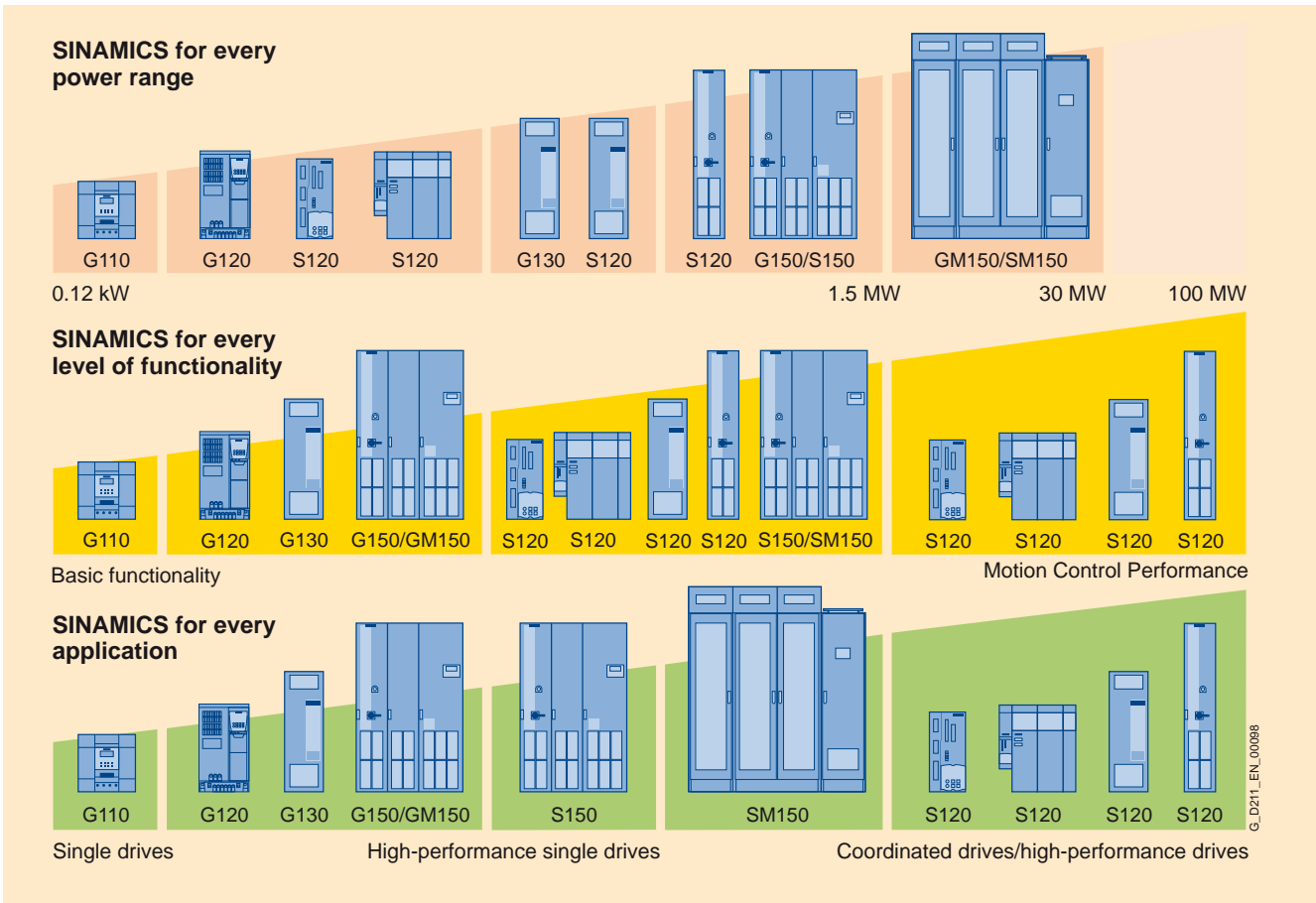

The SINAMICS drive family

Tailored to the respective areas of application, SINAMICS is divided into the following family members:

Low-voltage drives (line supply < 1000 V)

- **SINAMICS G110** – the versatile drive for low power ranges
- **SINAMICS G120** – the modular single drive for low to medium power ranges
- **SINAMICS G120D** – the distributed single drive with high degree of protection for design without control cabinet
- **SINAMICS G130** and **SINAMICS G150** – the universal drive solution for high-power single drives
- **SINAMICS S120** – the flexible, modular drive system for complex tasks
- **SINAMICS S150** – the sophisticated drive solution for high-performance single drives

Medium-voltage drives (line supply > 1000 V)

- **SINAMICS GM150** – the universal drive solution for single drives
- **SINAMICS SM150** – the sophisticated drive solution for single and multi-motor drives

The SINAMICS range is characterized by the following system features:

- uniform functionality based on a single platform concept
- standardized engineering
- high degree of flexibility and combination
- wide power range
- designed for global use
- SINAMICS Safety Integrated
- greater efficiency and effectivity
- multiple communications options
- Totally Integrated Automation

SINAMICS

Introduction

1

The members of the SINAMICS drive family

SINAMICS Low-voltage inverters

SINAMICS G110



The versatile drive for low power ranges

SINAMICS G120



The modular single drive for low to medium power ranges

SINAMICS G120D



The distributed single drive with a high degree of protection for a design without control cabinet

Main applications

- Machines and plants for industrial and commercial applications
- Machines and plants for industrial and commercial applications (mechanical engineering, automotive, textiles, chemicals, printing, steel)
- Machines and plants in the process and production industry, particularly for automotive applications; also suitable for high-performance applications, e.g. in airports and in the food processing industry and luxury food processing industry

Application examples

- Pumps and fans
- Auxiliary drives
- Conveyor belts
- Billboards
- Door/gate operating mechanisms
- Centrifuges
- Pumps and fans
- Compressors
- Conveyor belts
- Conveyor belts
- Electric suspension monorails in the logistics of distribution

Highlights

- Compact
- Flexible adaptation to different applications
- Simple, fast commissioning
- Clear terminal layout
- Optimum interaction with SIMATIC and LOGO!
- Modular
- Flexible expansion capability
- Simple, fast commissioning
- Regenerative feedback
- Innovative cooling concept
- Optimum interaction with SIMOTION and SIMATIC
- SINAMICS Safety Integrated
- Flat design with uniform drilling dimensions (constant footprint) with degree of protection IP65
- Modular
- Flexible expansion capability
- Simple, fast commissioning
- Regenerative feedback
- Innovative cooling concept
- Optimum interaction with SIMOTION and SIMATIC
- SINAMICS Safety Integrated

The members of the SINAMICS drive family

SINAMICS Low-voltage inverters

SINAMICS G130/G150



The universal drive solution for high-power single drives

SINAMICS S120



The flexible, modular drive system for complex drive tasks

SINAMICS S150



The sophisticated drive solution for high-performance single drives

Main applications

- Machines and plants in the process and production industry, water/waste, power stations, oil and gas, petrochemicals, chemical raw materials, paper, cement, stone, steel
- Machines and plants for industrial applications (packaging, plastics, textile, printing, wood, glass, ceramics, presses, paper, lifting equipment, semiconductors, automated assembly and testing equipment, handling, machine tools)
- Machines and plants in the process and production industry, food, beverages and tobacco, automotive and steel industry, mining/open-cast mining, shipbuilding, lifting equipment/conveyors

Application examples

- Pumps and fans
- Compressors
- Extruders and mixers
- Mills
- Motion Control applications (e.g. positioning, synchronous operation)
- Numeric Control, interpolated motion control
- Converting
- Technological applications
- Test bay drives
- Centrifuges
- Elevators and cranes
- Cross cutters and shears
- Conveyor belts
- Presses
- Cable winches

Highlights

- Space-saving
- Low-noise
- Simple, fast commissioning
- SINAMICS G130: modular components
- SINAMICS G150: ready-to-connect cabinet unit
- Optimum interaction with SIMATIC
- For universal use
- Flexible and modular
- Scalable in terms of power, function, number of axes, performance
- Simple, fast commissioning, auto-configuration
- Innovative system architecture
- Wide range of motors
- Optimum interaction with SIMOTION and SIMATIC
- SINAMICS Safety Integrated
- Four-quadrant operation as standard
- High control accuracy and dynamic response
- Almost no line harmonic distortions
- Tolerant to fluctuations in line voltage
- Option of power factor compensation
- Simple, fast commissioning
- Ready-to-connect cabinet unit
- Optimum interaction with SIMATIC

SINAMICS

Introduction

1

The members of the SINAMICS drive family

SINAMICS Medium-voltage inverters

SINAMICS GM150



The drive solution for variable-speed drives

SINAMICS SM150



The drive solution for high-performance variable-speed single and multi-motor drives

Main applications

- Machines and plants in the process industry
- Machines and plants, e.g. steel manufacture and mining

Application examples

- Pumps and fans
- Compressors
- Extruders and mixers
- Mills
- Marine drives
- Rolling mills
- Mine cages
- Test stands
- Conveyor belts

Highlights

- Space-saving
- Simple, fast commissioning
- Ready-to-connect cabinet unit
- Optimum interaction with SIMATIC
- Four-quadrant operation as standard
- High-efficiency and motor-friendly operation
- High level of control accuracy and dynamic response
- Almost no line harmonic distortions
- Option of power factor compensation
- Simple, fast commissioning
- Ready-to-connect cabinet unit
- Optimum interaction with SIMATIC

SINAMICS G110

Inverter chassis units

0.12 kW to 3 kW

2



2/2 **SINAMICS G110 chassis units**
2/2 Overview
2/2 Benefits

2/3 **Controlled Power Modules**
2/3 Application
2/3 Design
2/3 Function
2/4 Technical specifications
2/8 **Selection and ordering data**
2/9 **Accessories**
2/10 Dimensional drawings
2/11 Circuit diagrams

2/12 **Starter kit**
2/12 Overview
2/12 **Selection and ordering data**

2/13 **Line-side power components**
2/13 Overview
2/14 **Selection and ordering data**



SINAMICS G110

Inverter chassis units 0.12 kW to 3 kW

SINAMICS G110 chassis units

Overview



SINAMICS G110, frame size A (on the right with flat heat sink)



SINAMICS G110, frame sizes B and C

SINAMICS G110 is a frequency inverter with basic functions for a variety of industrial variable-speed drive applications.

The particularly compact SINAMICS G110 inverter operates with voltage frequency control on single-phase supplies (200 V to 240 V).

It is the ideal low-cost frequency inverter solution for the lower power range of the SINAMICS family.

The following **line-side power components** are available for SINAMICS G110 inverters:

- EMC filters
- Line reactors
- Fuses
- Circuit-breakers

The following **accessories** are also available:

- Operator panels
- Mounting accessories
- Commissioning tool

The latest technical documentation (catalogs, dimensional drawings, certificates, user manuals and operating instructions) is available on the Internet at:

<http://www.siemens.com/sinamics-g110>

and also on CD-ROM CA 01 Vol. 2 "Planning" in the SD configurator, which can be ordered from the following address:

<http://www.siemens.com/automation/CA01>

Benefits

- Simple installation, parameterization, and commissioning
- Robust EMC design
- Large parameter range enables configurations for a wide range of applications
- Simple cable connection
- Scaleable functionality with analog and USS variants
- Low-noise motor operation resulting from high pulse frequency
- Status information and alarms via the optional BOP (Basic Operator Panel)
- Rapid copying of parameters via the optional BOP
- External options for PC communication and BOP
- Fast, repeatable digital input response time for rapid-response applications
- Fine adjustment using a high-resolution 10-bit analog input (analog variants only)
- LED for status information
- Variants with internal EMC filter class A or B
- DIP switches for easy adaptation to 50 Hz or 60 Hz applications
- DIP switches for simple bus termination for the USS version (RS485)
- Bus-capable serial RS485 interface (USS variants only) enables integration in a networked drive system
- 2/3-wire method (static/pulsated signals) for universal control via digital inputs
- Variable lower voltage limit in DC link to ensure controlled motor braking if the power fails

Accessories (overview)

- BOP operator panel
- Adapter for installation on DIN rail (frame sizes A and B)
- PC inverter connection kit
- STARTER commissioning tool

Line-side power components (overview)

- EMC filter class B with low leakage currents
- Additional EMC filter, class B
- Line reactors

International standards

- Fulfills the requirements of the EU low-voltage guidelines
- CE mark
- Certified to UL and cUL
- c-tick

SINAMICS G110

Inverter chassis units 0.12 kW to 3 kW

Controlled Power Modules

2

Application

SINAMICS G110 is especially suited for use with pumps and fans, or as a drive in various industrial sectors, such as the food, textile and packaging industries, as well as for conveyor systems, factory gate and garage door operating mechanisms, and as a universal drive for moving billboards.

Design

The SINAMICS G110 inverter chassis units are equipped with a control and power module and provide CPM 110 inverters (Controlled Power Module) with a compact and efficient design. They operate with the latest IGBT technology and digital micro-processor control.

The SINAMICS G110 inverter product range consists of the following variants and versions:

- The **analog variant** is available in the following versions:
 - Without EMC filter, with heat sink
 - Integrated EMC filter, class A/B, with heat sink
 - Without EMC filter, with flat heat sink (FSA only)
 - Integrated EMC filter, class B, with flat heat sink (FSA only).
- The **USS variant** (RS485) is available in the following versions:
 - Without EMC filter, with heat sink
 - Integrated EMC filter, class A/B, with heat sink
 - Without EMC filter, with flat heat sink (FSA only)
 - Integrated EMC filter, class B, with flat heat sink (FSA only).

With housing size FSA, cooling is achieved through a heat sink and natural convection. The FSA design with flat heat sink offers space-saving and favorable heat dissipation since an additional heat sink can be installed outside the control cabinet. With housing sizes FSB and FSC, an integrated fan is used to cool the heat sink which has resulted in the compact design.

The connections for all inverter variants are easily accessible and in the same location. To ensure optimum electromagnetic compatibility and easy connection, the line and motor connections are located on opposite sides (as with contactors). The control terminal block does not require screws to install it.

The optional BOP (Basic Operator Panel) can be installed without the use of tools.

Function

- Careful handling of the machine mechanical system due to a skip frequency band in case of resonance, parameterizable ramp up/ramp down times up to 650 s, ramp smoothing, as well as bringing the inverter into circuit on turning motor (flying start)
- Increased installation availability by automatic restart facility following power failure or fault
- Fast current limit (FCL) for trip-free operation in case of sudden load changes
- Programmable V/f characteristic (e.g. for synchronous motors)
- Fast DC and compound braking without external braking resistor
- Limitation of DC link voltage by means of the V_{DCmax} controller
- Slip compensation, electronic motor potentiometer function and three fixed speed setpoints
- Configurable voltage boost for higher dynamic response when starting and accelerating
- Motor holding brake function to control an external mechanical brake

SINAMICS G110

Inverter chassis units 0.12 kW to 3 kW

Controlled Power Modules

Technical specifications

	Controlled Power Modules
Power range	0.12 ... 3.0 kW
Line voltage	200 ... 240 V 1 AC ±10%
Line frequency	47 ... 63 Hz
Output frequency	0 ... 650 Hz
cos φ	≥ 0.95
Inverter efficiency	90 ... 94%
• with devices < 0.75 kW	90 ... 94%
• with devices ≥ 0.75 kW	≥ 95%
Overload capability	Overload current 1.5 × rated output current (i.e. 150% overload) for 60 s, then 0.85 × rated output current for 240 s, cycle time 300 s
Inrush current	Less than rated input current
Control methods	Linear V/f characteristic (with parameterizable voltage boost); quadratic V/f characteristic; multipoint characteristic (parameterizable V/f characteristic)
Pulse frequency	8 kHz (standard) 2 ... 16 kHz (in 2 kHz increments)
Fixed frequencies	3, programmable
Skipped frequency range	1, programmable
Setpoint resolution	0.01 Hz digital 0.01 Hz serial 10 bit analog (motorized potentiometer 0.1 Hz)
Digital inputs	3 programmable digital inputs, non-floating, PNP, SIMATIC-compatible
Analog input (analog variant)	1, for setpoint (0 V to 10 V, scaleable or for use as 4th digital input)
Digital output	1 isolated optocoupler output (24 V DC, 50 mA, ohmic, NPN type)
Universal serial interface (USS variant)	RS485, for operation with USS protocol
Motor cable length, max.	
• Shielded	25 m
• Unshielded	50 m
Electromagnetic compatibility	All devices with integrated EMC filter for drive systems in category C2 installations (limit value in accordance with EN 55011, class A, group 1) and category C3 installations (limit value in accordance with EN 55011, class A, group 2). All devices with an integrated EMC filter and shielded cables with a maximum length of 5 m also fulfill the limit values of EN 55011, class B.
Braking	DC braking, compound braking
Degree of protection	IP20
Operating temperature	-10 ... +40 °C up to +50 °C with derating
Storage temperature	-40 ... +70 °C
Relative humidity	95% (non-condensing)
Installation altitude	Up to 1000 m above sea level without derating
	• Rated output current at 4000 m above sea level: 90%
	• Line voltage up to 2000 m above sea level: 100% at 4000 m above sea level: 75%
Standard SCCR (Short Circuit Current Rating) ¹⁾	10 kA
Protective functions for	<ul style="list-style-type: none"> • Undervoltage • Overvoltage • Ground fault • Short-circuit • Stall prevention • Thermal motor protection I^2t • Inverter overtemperature • Motor overtemperature
Compliance with standards	UL, cUL, CE, c-tick
CE mark	Conformity with Low-Voltage Directive 73/23/EEC

¹⁾ Applies to industrial control cabinet installations to NEC article 409/UL 508A. For further information, visit us on the Internet at: <http://support.automation.siemens.com/WWW/view/en/23995621>

SINAMICS G110

Inverter chassis units 0.12 kW to 3 kW

Controlled Power Modules

Technical specifications (continued)

	Controlled Power Modules						
	• FSA ≤ 0.37 kW	• FSA 0.55 kW and 0.75 kW	• FSA ≤ 0.37 kW with flat heat sink	• FSA 0.55 kW and 0.75 kW with flat heat sink	• FSB 1.1 kW and 1.5 kW	• FSC 2.2 kW	• FSC 3.0 kW
Dimensions (without accessories)							
• Width	90	90	90	90	140	184	184
• Height	150	150	150	150	160	181	181
• Depth	116	131	101	101	142	152	152
Weight, approx.							
• Without filter	0.7	0.8	0.6	0.7	1.4	1.9	2.0
• with filter	0.8	0.9	0.7	0.8	1.5	2.1	2.2

Technical specifications for variant with flat heat sink

The design with flat heat sink offers space-saving and favorable heat dissipation since an additional heat sink can be installed outside the control cabinet.

	Controlled Power Modules FSA with flat heat sink				
	0.12 kW	0.25 kW	0.37 kW	0.55 kW	0.75 kW
Operating temperature	-10 ... +50 °C	-10 ... +50 °C	-10 ... +50 °C	-10 ... +50 °C	-10 ... +40 °C
Total power losses at full load and maximum operating temperature as specified	22 W	28 W	36 W	43 W	54 W
Line-side and control electronics losses	9 W	10 W	12 W	13 W	15 W
Recommended thermal resistance of heat sink	3.0 K/W	2.2 K/W	1.6 K/W	1.2 K/W	1.2 K/W
Recommended output current	0.9 A	1.7 A	2.3 A	3.2 A	3.9 A

Derating data and power loss

Pulse frequency

Output kW	Power loss W	Rated output current in A at a pulse frequency of							
		2 kHz	4 kHz	6 kHz	8 kHz	10 kHz	12 kHz	14 kHz	16 kHz
0.12	22	0.9	0.9	0.9	0.9	0.9	0.9	0.9	0.9
0.25	28	1.7	1.7	1.7	1.7	1.7	1.7	1.7	1.7
0.37	36	2.3	2.3	2.3	2.3	2.3	2.3	2.3	2.3
0.55	43	3.2	3.2	3.2	3.2	3.0	2.7	2.5	2.2
0.75 (at 40 °C)	54	3.9	3.9	3.9	3.9	3.6	3.3	3.0	2.7
0.75	54	3.2	3.2	3.2	3.2	3.0	2.7	2.5	2.2
1.1	86	6.0	6.0	6.0	6.0	5.9	5.7	5.6	5.4
1.5 (at 40 °C)	118	7.8	7.8	7.8	7.8	7.6	7.4	7.2	7.0
1.5	118	6.0	6.0	6.0	6.0	5.9	5.7	5.6	5.4
2.2	174	11.0	11.0	11.0	11.0	10.8	10.5	10.2	9.9
3.0 (at 40 °C)	210	13.6	13.6	13.6	13.6	13.3	12.9	12.6	12.3
3.0	210	11.0	11.0	11.0	11.0	10.8	10.5	10.2	9.9

The current data apply to an ambient temperature of 50 °C unless specified otherwise.

SINAMICS G110

Inverter chassis units 0.12 kW to 3 kW

Controlled Power Modules

Technical specifications (continued)

Compliance with standards

CE mark



The SINAMICS G110 inverters meet the requirements of the Low-Voltage Directive 73/23/EEC.

Low-voltage directive

The inverters comply with the following standards listed in the EU gazette:

- EN 60204
Safety of machinery, electrical equipment of machines
- EN 61800-5-1
Electrical power drive systems with variable speed – Part 5-1: Requirements regarding safety – electrical, thermal, and energy requirements

UL listing



Converter devices in UL category NMMS certified to UL and cUL, in compliance with UL508C. UL list number E121068.

For use in pollution degree 2 environment.

On the Internet at <http://www.ul.com>

Machine directive

The inverters are suitable for installation in machines. Compliance with the machine directive 89/392/EEC requires a separate certificate of conformity. This must be provided by the plant constructor or the installer of the machine.

EMC directive

- EN 61800-3
Variable-speed electric drives
Part 3: EMC product standard including specific test methods

The modified EMC product standard EN 61800-3 for electrical drive systems is valid since 07/01/2005. The transition period for the predecessor standard EN 61800-3/A11 from February 2001 ends on October 1, 2007. The following information applies to the SINAMICS G110 frequency inverters from Siemens:

- The EMC product standard EN 61800-3 does not apply directly to a frequency inverter but to a PDS (Power Drive System), which comprises the complete circuitry, motor and cables in addition to the inverter.
- Frequency inverters are normally only supplied to experts for installation in machines or systems. A frequency inverter must, therefore, only be considered as a component which, on its own, is not subject to the EMC product standard EN 61800-3. The inverter's Instruction Manual, however, specifies the conditions regarding compliance with the product standard if the frequency inverter is expanded to a PDS. The EMC directive in the EU is complied with for a PDS by observance of the product standard EN 61800-3. The frequency inverters on their own do not generally require identification according to the EMC directive.

- In the new EN 61800-3 of July 2005, a distinction is no longer made between "general availability" and "restricted availability". Instead, different categories have been defined, C1 to C4, in accordance with the environment of the PDS at the operating site:
 - **Category C1:** Drive systems for rated voltages < 1000 V for use in environment 1
 - **Category C2:** Stationary drive systems not connected by means of a plug connector for rated voltages < 1000 V. When used in environment 1, the system must be installed and commissioned by personnel familiar with EMC requirements. A warning is required.
 - **Category C3:** Drive systems for rated voltages < 1000 V for exclusive use in the second environment. A warning is required.
 - **Category C4:** Drive systems for rated voltages ≥ 1000 V, for rated currents ≥ 400 A, or for use in complex systems in environment 2. An EMC plan must be created.
- The EMC product standard EN 61800-3 also defines limit values for conducted interference and radiated interference for "environment 2" (= industrial power supply systems that do not supply households). These limit values are below the limit values of filter class A to EN 55011. Unfiltered inverters can be used in industrial environments as long as they are installed in a system that contains line filters on the higher-level infeed side.
- With SINAMICS G110, Power Drive Systems (PDS) that fulfill EMC product standard EN 61800-3 can be set up (see the setup instructions). The table "Overview of SINAMICS G110 components and PDS categories" and the SINAMICS G110 ordering documentation show which of the components can be installed directly in a PDS.
- A differentiation must be made between the product standards for electrical drive systems (PDS) of the range of standards EN 61800 (of which Part 3 covers EMC topics) and the product standards for the devices/systems/machines, etc. This will probably not result in any changes in the practical use of frequency inverters. Since frequency inverters are always part of a PDS and these are part of a machine, the machine manufacturer must observe various standards depending on their type and environment (e.g. EN 61000-3-2 for line harmonics and EN 55011 for radio interference). The product standard for PDS on its own is, therefore, either insufficient or irrelevant.
- Regarding the compliance of limit values for line harmonics, EMC product standard EN 61800-3 for PDS refers to compliance with EN 61000-3-2 and EN 61000-3-12.
- Regardless of the configuration with SINAMICS G110 and its components, the mechanical engineer can also implement other measures to ensure that the machine complies with the EU EMC directive. The EU EMC directive is generally fulfilled when the relevant EMC product standards are observed. If they are not available, the generic standards (e.g. DIN EN 61000-x-x) can be used instead. It is important that the conducted and emitted interference at the line connection point and outside the machine remain below the relevant limit values. Any suitable technical means can be used to ensure this.

SINAMICS G110

Inverter chassis units 0.12 kW to 3 kW

Controlled Power Modules

Technical specifications (continued)

Overview of SINAMICS G110 components and PDS categories

Environment 1 (Residential, commercial)	Category C1	Environment 2 Industrial
	Unfiltered devices and external filter class B with low leakage currents (shielded motor cable up to 5 m)	
	<p>Category C2</p> <p>All devices with integrated filter (shielded motor cable up to 5 m)</p> <p>or</p> <p>All devices with integrated filter (frame size FSA: up to 10 m; FSB and FSC: shielded motor cable up to 25 m) + warning</p> <p>or</p> <p>All devices with integrated filter + external filter, class B (shielded motor cable up to 25 m)</p>	<p>Category C2</p> <p>All devices with integrated filter (shielded motor cable up to 5 m)</p> <p>or</p> <p>All devices with integrated filter (frame size FSA: up to 10 m; FSB and FSC: shielded motor cable up to 25 m)</p> <p>or</p> <p>All devices with integrated filter + external filter, class B (shielded motor cable up to 25 m)</p> <p>Note: When devices with an integrated filter and a max. motor cable length of 5 m or external class B filters are used, this exceeds the requirements of EN 61800-3 by a considerable margin!</p>
	<p>Category C3</p> <p>All devices with integrated filter (frame size FSA: up to 10 m; FSB and FSC: shielded motor cable up to 25 m)</p> <p>or</p> <p>All devices with integrated filter + external filter, class B (shielded motor cable up to 25 m)</p> <p>A warning is required.</p> <p>Note: When devices with an integrated filter and external class B filters are used, this exceeds the requirements of EN 61800-3 by a considerable margin!</p>	
	<p>Category C4</p> <p>Not applicable to SINAMICS G110</p>	

Electromagnetic compatibility

No impermissible electromagnetic radiation occurs if the installation guidelines specific to the product are correctly observed.

The table below lists the measured results for emissions of and immunity to interference for the SINAMICS G110 inverters.

The inverters were installed according to the guidelines with shielded motor cables and shielded control cables.

EMC phenomenon Standard/test	Relevant criteria	Limit value
Noise emissions EN 61800-3 (environment 1)	Conducted via mains cable	150 kHz to 30 MHz Unfiltered devices: not tested All devices with internal/external filter: Depending on filter type and planned PDS installation: Category C1: limit complies with EN 55011, class B. Category C2: limit complies with EN 55011, class A, Group 1. All devices with an internal/external filter also fulfill the limit for category C3 installations. Limit complies with EN 55011, class A, group 2.
	Emitted by the drive	30 MHz to 1 GHz All devices limit complies with EN 55011, class A, Group 1
ESD immunity EN 61000-4-2	ESD by air discharge	Test level 3 8 kV
	ESD by contact discharge	Test level 3 6 kV
Electrical fields immunity EN 61000-4-3	Electrical field applied to unit	Test level 3 80 MHz to 1 GHz 10 V/m
Burst interference immunity EN 61000-4-4	Applied to all cable terminations	Test level 4 4 kV
Surge immunity EN 61000-4-5	Applied to mains cables	Test level 3 2 kV
Immunity to RFI emissions, conducted EN 61000-4-6	Applied to mains, motor and control cables	Test level 3 0.15 MHz to 80 MHz 80% AM (1 kHz) 10 V

SINAMICS G110

Inverter chassis units 0.12 kW to 3 kW

Controlled Power Modules

Selection and ordering data

Output		Rated input current (at 230 V)		Rated output current	Frame size	Type	SINAMICS G110 without filter	SINAMICS G110 with integrated filter	Filter class ¹⁾ With use of shielded cables with a max. cable length of		
kW	hp	A	A	A	(Frame size)		Order No.	Order No.	5 m	10 m	25 m
0.12	0.16	2.3	0.9	FSA	Analog	6SL3211-0AB11-2UA1	6SL3211-0AB11-2BA1	B	A ²⁾	A ²⁾	
						6SL3211-0AB11-2UB1	6SL3211-0AB11-2BB1	B	A ²⁾	A ²⁾	
						6SL3211-0KB11-2UA1	6SL3211-0KB11-2BA1	B	A ²⁾	A ²⁾	
						6SL3211-0KB11-2UB1	6SL3211-0KB11-2BB1	B	A ²⁾	A ²⁾	
0.25	0.33	4.5	1.7	FSA	Analog	6SL3211-0AB12-5UA1	6SL3211-0AB12-5BA1	B	A ²⁾	A ²⁾	
						6SL3211-0AB12-5UB1	6SL3211-0AB12-5BB1	B	A ²⁾	A ²⁾	
						6SL3211-0KB12-5UA1	6SL3211-0KB12-5BA1	B	A ²⁾	A ²⁾	
						6SL3211-0KB12-5UB1	6SL3211-0KB12-5BB1	B	A ²⁾	A ²⁾	
0.37	0.5	6.2	2.3	FSA	Analog	6SL3211-0AB13-7UA1	6SL3211-0AB13-7BA1	B	A ²⁾	A ²⁾	
						6SL3211-0AB13-7UB1	6SL3211-0AB13-7BB1	B	A ²⁾	A ²⁾	
						6SL3211-0KB13-7UA1	6SL3211-0KB13-7BA1	B	A ²⁾	A ²⁾	
						6SL3211-0KB13-7UB1	6SL3211-0KB13-7BB1	B	A ²⁾	A ²⁾	
0.55	0.75	7.7	3.2	FSA	Analog	6SL3211-0AB15-5UA1	6SL3211-0AB15-5BA1	B	A ²⁾	A ²⁾	
						6SL3211-0AB15-5UB1	6SL3211-0AB15-5BB1	B	A ²⁾	A ²⁾	
						6SL3211-0KB15-5UA1	6SL3211-0KB15-5BA1	B	A ²⁾	A ²⁾	
						6SL3211-0KB15-5UB1	6SL3211-0KB15-5BB1	B	A ²⁾	A ²⁾	
0.75	1.0	10.0	3.9 (at 40 °C)	FSA	Analog	6SL3211-0AB17-5UA1	6SL3211-0AB17-5BA1	B	A ²⁾	A ²⁾	
						6SL3211-0AB17-5UB1	6SL3211-0AB17-5BB1	B	A ²⁾	A ²⁾	
						6SL3211-0KB17-5UA1	6SL3211-0KB17-5BA1	B	A ²⁾	A ²⁾	
						6SL3211-0KB17-5UB1	6SL3211-0KB17-5BB1	B	A ²⁾	A ²⁾	
1.1	1.5	14.7	6.0	FSB	Analog	6SL3211-0AB21-1UA1	6SL3211-0AB21-1AA1	B	A ²⁾	A ²⁾	
						6SL3211-0AB21-1UB1	6SL3211-0AB21-1AB1	B	A ²⁾	A ²⁾	
1.5	2.0	19.7	7.8 (at 40 °C)	FSB	Analog	6SL3211-0AB21-5UA1	6SL3211-0AB21-5AA1	B	A ²⁾	A ²⁾	
						6SL3211-0AB21-5UB1	6SL3211-0AB21-5AB1	B	A ²⁾	A ²⁾	
2.2	3.0	27.2	11.0	FSC	Analog	6SL3211-0AB22-2UA1	6SL3211-0AB22-2AA1	B	A ²⁾	A ²⁾	
						6SL3211-0AB22-2UB1	6SL3211-0AB22-2AB1	B	A ²⁾	A ²⁾	
3.0	4.0	35.6	13.6 (at 40 °C)	FSC	Analog	6SL3211-0AB23-0UA1	6SL3211-0AB23-0AA1	B	A ²⁾	A ²⁾	
						6SL3211-0AB23-0UB1	6SL3211-0AB23-0AB1	B	A ²⁾	A ²⁾	

The current data apply to an ambient temperature of 50 °C unless specified otherwise.

The last digit of the complete order number for the SINAMICS G110 inverters represents the release version. When ordering, a different digit from the one specified may be present as a result of further technical development.

All SINAMICS G110 inverters are supplied without an operator panel (OP). A BOP or other accessories must be ordered separately.

¹⁾ The **highlighted** filter class is quoted on the rating plate of the inverter.

²⁾ Class B also with additional filter.

SINAMICS G110

Inverter chassis units 0.12 kW to 3 kW

Controlled Power Modules

Accessories

Basic operator panel (BOP)



The BOP can be used to make individual parameter settings. Values and units are displayed via a 5-digit display.

One BOP can be used for several inverters. It is plugged directly into the inverter.

The BOP offers a function that enables you to copy parameters quickly and easily. A parameter set of one inverter can be saved and then loaded to another inverter.

PC inverter connection kit

For controlling and commissioning an inverter directly from a PC if the appropriate software (STARTER) has been installed.

Isolated RS232 adapter module for a reliable point-to-point connection to a PC.

The scope of supply includes a 9-pin Sub-D connector, an RS232 standard cable (3 m), and the STARTER commissioning tool on CD-ROM.

Commissioning tool

STARTER is a commissioning tool with a graphical interface for commissioning SINAMICS G110 frequency inverters in Windows NT/2000/XP Professional. It can be used to read, change, store, enter, and print parameter lists.

Selection and ordering data

The accessories listed here are suitable for all SINAMICS G110 inverters.

Accessories	Order No.
BOP (Basic Operator Panel)	6SL3255-0AA00-4BA1
PC inverter connection kit incl. 9-pin Sub-D connector, standard RS232 cable (3 m), and STARTER commissioning tool on CD-ROM ¹⁾	6SL3255-0AA00-2AA1
Adapter for DIN rail attachment	
• Size 1 (FSA)	6SL3261-1BA00-0AA0
• Size 2 (FSB)	6SL3261-1BB00-0AA0
Documentation CD , with operating instructions, parameter list, and Getting Started guide	6SL3271-0CA00-0AG0
STARTER commissioning tool on CD-ROM ¹⁾	6SL3072-0AA00-0AG0

¹⁾ STARTER commissioning tool also available on the Internet at <http://www4.ad.siemens.de/WWW/view/de/10804985/133100>

SINAMICS G110

Inverter chassis units 0.12 kW to 3 kW

Controlled Power Modules

Dimensional drawings

2

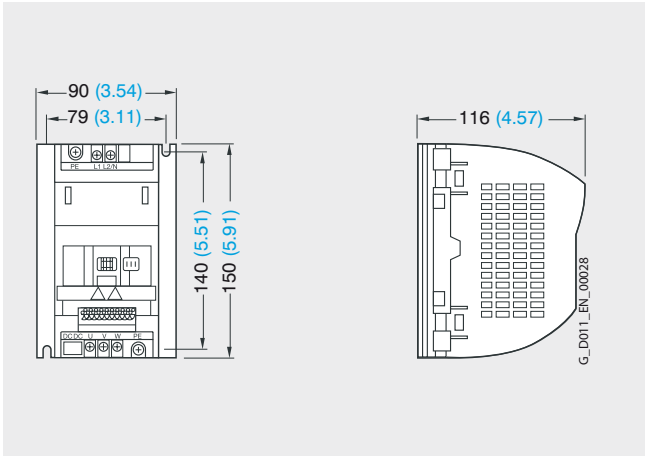

Inverter FSA; 0.12 kW to 0.37 kW

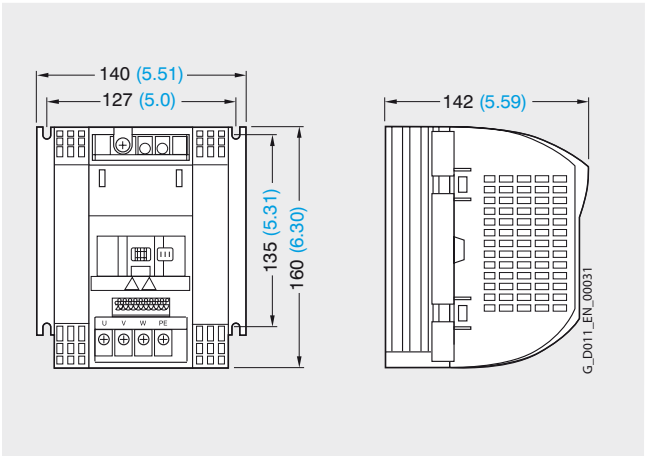

Inverter FSB; 1.1 kW to 1.5 kW

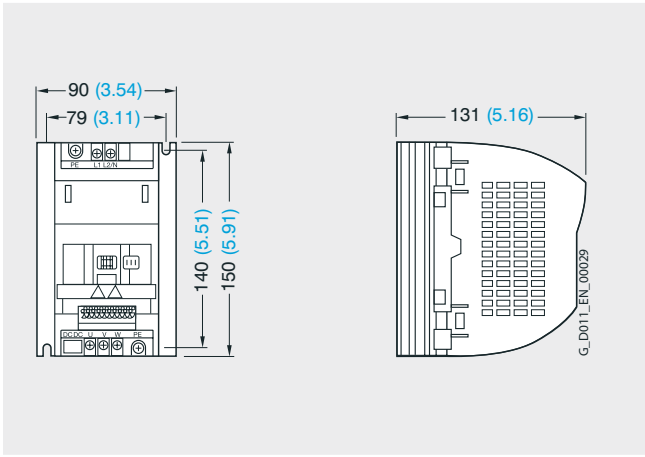

Inverter FSA; 0.55 kW to 0.75 kW

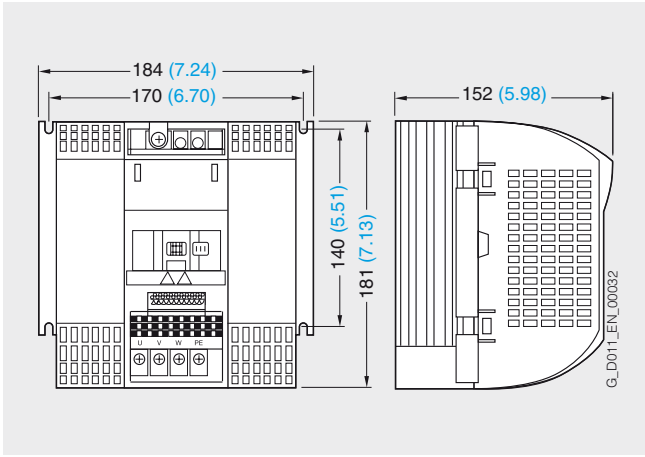

Inverter FSC; 2.2 kW to 3.0 kW

With attached operator panel (BOP), the mounting depth is increased by 8 mm (0.31 inches).

All dimensions in mm (values in brackets are in inches).

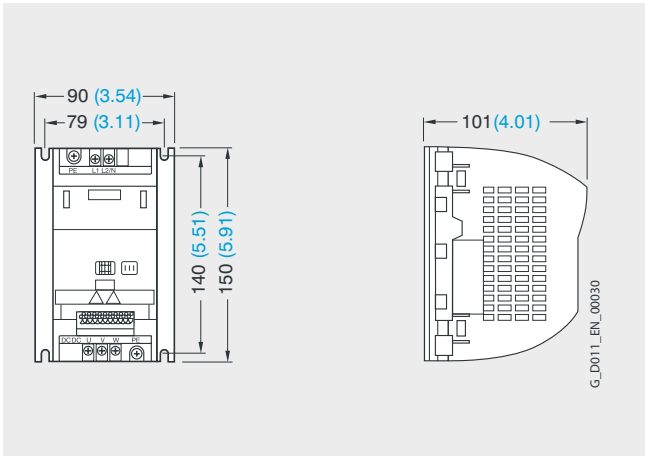

Inverter FSA with flat heat sink; 0.12 kW to 0.75 kW

SINAMICS G110

Inverter chassis units 0.12 kW to 3 kW

Controlled Power Modules

Schematics
General circuit diagram

2

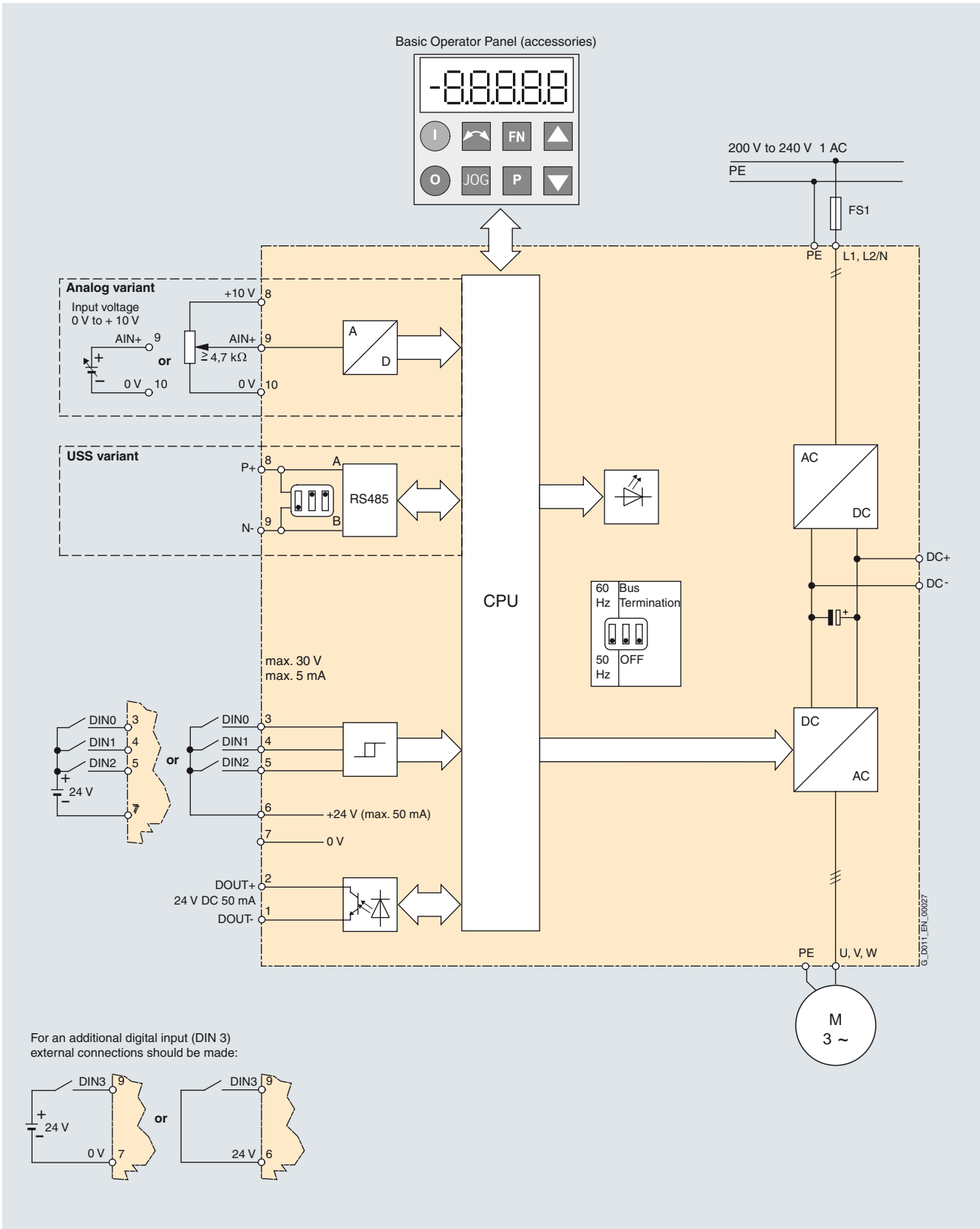

SINAMICS G110

Inverter chassis units 0.12 kW to 3 kW

Starter kit

Overview



The SINAMICS G110 starter kit offers an easy introduction to variable-speed drives.

Available in a stackable transport case, it contains:

- Inverter (0.75 kW) with analog input and integrated EMC filter
- BOP operator panel
- PC inverter connection kit
- Short description, operating instructions, and parameter list (hard copy, in German)
- STARTER commissioning tool on CD-ROM incl. operating instructions, parameter list, and Getting Started guide
- Screwdriver

Selection and ordering data

Starter kit
0.75 kW, German

Order No.

6SL3200-0AB10-0AA0

Overview

Integrated EMC filter

Versions with integrated EMC filters class A and class B are available for the corresponding environments.

- **Class A**
The requirements are fulfilled when shielded cables with a max. length of 10 m (for FSA) or 25 m (for FSB and FSC) are used. The limits comply with EN 55011 class A.
- **Class B**
The requirements are fulfilled when shielded cables with a max. length of 5 m are used. The limits comply with EN 55011 class B.

An inverter with an integrated filter can be used with a 30 mA residual-current circuit-breaker and is only suitable for installations with fixed wiring.

Inverters without filters, which are used with “filter class B with low leakage currents”, have a leakage current of < 3.5 mA (up to 5 m shielded motor cable).

Additional EMC filter, class B

Available for inverters with an internal EMC filter.

With this filter, the inverter complies with the emission standard EN 55011, class B.

The requirements are fulfilled using shielded cables with a max. length of 25 m.

Filter class B with low leakage currents

With this filter, the inverter complies with emission standard EN 55011, class B. The leakage currents are reduced to < 3.5 mA.

Unfiltered inverters can, therefore, be used for drive systems in Category C1 installations.

The requirements are fulfilled with

- Shielded cables with a max. length of 5 m
- Installation of the inverter in a metal housing (e.g. control cabinet)
- Pulse frequency of 16 kHz (only for FSB and FSC)

With Category C1 installations, generally a pulse frequency of 16 kHz is recommended for converter operation in the inaudible spectrum and for quiet motor operation.

Line reactor

Line reactors are used to smooth voltage peaks or to bridge commutating dips.

Line reactors also reduce the effects of harmonics on the inverter and the power supply.

If the ratio of the rated inverter power to supply short-circuit power is less than 1%, a line reactor must be used in order to reduce the current peaks.

In line with EN 61000-3-2 regulations “Limits for harmonic currents with device input current ≤ 16 A per phase”, there are special aspects for drives with 120 W to 550 W and 230 V single-phase supplies which can be used in non-industrial applications (environment 1).

For devices with 120 W to 370 W, either the recommended line reactors must be installed or a permission obtained from the power supplier for the connection to the public supply system.

In accordance with the specifications of EN 61000-3-12 “Limits for harmonic currents > 16 A and ≤ 75 A per phase”, a permission to operate drives on the public low-voltage network must be obtained from the power supplier. For the harmonic currents, see the instruction manual.

SINAMICS G110

Inverter chassis units 0.12 kW to 3 kW

Line-side power components

Selection and ordering data

The line-side power components listed here must be selected in accordance with the inverter. EMC filters and line reactors are not suitable for base-type installation.

The inverter and associated line-side power components have the same rated voltage.

All line-side power components are certified to UL (with the exception of fuses). Fuses of type 3NA3 are recommended for European countries. Further information about the listed fuses and circuit-breakers can be found in Catalogs LV 1 and LV 1 T.

UL-listed fuses such as the class NON fuse series from Bussmann are required for North American countries.

Output		Filter class B with low leakage currents	Line reactor	Additional EMC filter, class B	Fuse	Circuit-breakers
kW	hp	Order No.	Order No.	Order No.	Order No.	Order No.
Line-side power components for inverters without filter						
0.12	0.16	6SE6400-2FL01-0AB0	6SE6400-3CC00-4AB3	–	3NA3803	3RV1021-1DA10
0.25	0.33	6SE6400-2FL01-0AB0	6SE6400-3CC00-4AB3	–	3NA3803	3RV1021-1FA10
0.37	0.50	6SE6400-2FL01-0AB0	6SE6400-3CC01-0AB3	–	3NA3803	3RV1021-1HA10
0.55	0.75	6SE6400-2FL01-0AB0	6SE6400-3CC01-0AB3	–	3NA3803	3RV1021-1JA10
0.75	1.0	6SE6400-2FL01-0AB0	6SE6400-3CC01-0AB3	–	3NA3805	3RV1021-1KA10
1.1	1.5	6SE6400-2FL02-6BB0	6SE6400-3CC02-6BB3	–	3NA3807	3RV1021-4BA10
1.5	2.0	6SE6400-2FL02-6BB0	6SE6400-3CC02-6BB3	–	3NA3810	3RV1021-4CA10
2.2	3.0	6SE6400-2FL02-6BB0	6SE6400-3CC02-6BB3	–	3NA3814	3RV1031-4EA10
3.0	4.0	–	6SE6400-3CC03-5CB3	–	3NA3820	3RV1031-4FA10
Line-side power components for inverters with integrated filter class A/B						
0.12	0.16	–	6SE6400-3CC00-4AB3	6SE6400-2FS01-0AB0	3NA3803	3RV1021-1DA10
0.25	0.33	–	6SE6400-3CC00-4AB3	6SE6400-2FS01-0AB0	3NA3803	3RV1021-1FA10
0.37	0.50	–	6SE6400-3CC01-0AB3	6SE6400-2FS01-0AB0	3NA3803	3RV1021-1HA10
0.55	0.75	–	6SE6400-3CC01-0AB3	6SE6400-2FS01-0AB0	3NA3803	3RV1021-1JA10
0.75	1.0	–	6SE6400-3CC01-0AB3	6SE6400-2FS01-0AB0	3NA3805	3RV1021-1KA10
1.1	1.5	–	6SE6400-3CC02-6BB3	6SE6400-2FS02-6BB0	3NA3807	3RV1021-4BA10
1.5	2.0	–	6SE6400-3CC02-6BB3	6SE6400-2FS02-6BB0	3NA3810	3RV1021-4CA10
2.2	3.0	–	6SE6400-3CC02-6BB3	6SE6400-2FS02-6BB0	3NA3814	3RV1031-4EA10
3.0	4.0	–	6SE6400-3CC03-5CB3	6SE6400-2FS03-5CB0	3NA3820	3RV1031-4FA10

SINAMICS G120

Inverter chassis units

0.37 kW to 90 kW

3



3/2 SINAMICS G120 chassis units

- 3/2 Overview
- 3/3 Benefits
- 3/3 Application
- 3/4 Design
- 3/5 Configuration
- 3/6 Technical specifications

3/7 CU240 Control Units

- 3/7 Overview
- 3/7 [Selection and ordering data](#)
- 3/8 Design
- 3/9 Integration
- 3/13 Technical specifications

3/15 Memory card for Control Units

- 3/15 Overview
- 3/15 Integration
- 3/15 [Selection and ordering data](#)

3/16 PM240 Power Modules

- 3/16 Overview
- 3/17 Integration
- 3/19 Technical specifications
- 3/24 [Selection and ordering data](#)
- 3/25 Characteristic curves
- 3/26 Dimensional drawings

3/31 PM250 Power Modules

- 3/31 Overview
- 3/32 Integration
- 3/34 Technical specifications
- 3/38 [Selection and ordering data](#)
- 3/39 Characteristic curves
- 3/40 Dimensional drawings

3/43 PM260 Power Modules

- 3/43 Overview
- 3/44 Integration
- 3/45 Technical specifications
- 3/48 [Selection and ordering data](#)
- 3/48 Characteristic curves
- 3/49 Dimensional drawings

3/50 Line-side power components

- 3/50 Line filters
- 3/52 Line reactors
- 3/55 Recommended line components

3/57 DC link components

- 3/57 Braking resistors

3/59 Load-side power components

- 3/59 Output reactors

3/64 Supplementary system components

- 3/64 Basic Operator Panel BOP
- 3/64 PC inverter connection kit
- 3/65 Brake Relay
- 3/66 Safe Brake Relay
- 3/67 Adapter for DIN rail attachment
- 3/67 Shield connection kit
- 3/68 NEMA1 mounting kit



SINAMICS G120

Inverter chassis units 0.37 kW to 90 kW

SINAMICS G120 chassis units

Overview

The new SINAMICS G120 series of frequency inverters is designed to provide precise and cost-effective speed/torque control of AC motors.

With different device versions (frame sizes FSA to FSF) in a power range of 0.37 kW to 90 kW, it is suitable for a wide variety of drive solutions.



Examples of SINAMICS G120, frame sizes FSA, FSB and FSC; each with Power Module, Control Unit and Basic Operator Panel



Examples of SINAMICS G120, frame sizes FSD, FSE and FSF; each with Power Module, Control Unit and Basic Operator Panel

SINAMICS G120

Inverter chassis units 0.37 kW to 90 kW

SINAMICS G120 chassis units

Overview (continued)

Modularity

SINAMICS G120 is a modular converter system comprising a variety of functional units. The two main units are

- the Control Unit (CU) and
- the Power Module (PM)

The **Control Unit** controls and monitors the Power Module and the connected motor in several different modes. It supports communication with a local or central controller and monitoring devices.

The **Power Module** supplies the motor in the power range 0.37 kW to 90 kW. The Power Module is controlled by a micro-processor in the Control Unit. It features state-of-the-art IGBT technology with pulse-width-modulated motor voltage and selectable pulse frequency. It also features a range of functions offering a high degree of protection for the Power Module and motor.

Furthermore, a large number of additional components is available, such as:

- Basic Operator Panel (BOP) for parameterizing, diagnosing, controlling, and copying drive parameters
- Line filter, classes A and B
- Line reactors
- Braking resistors
- Output reactors

Safety integrated

The SINAMICS G120 inverter chassis units are available in a number of different variants for safety-oriented applications. All Power Modules are already designed for Safety Integrated. A Safety Integrated Drive can be created by combining a Power Module with the relevant Failsafe Control Unit.

The SINAMICS G120 fail-safe frequency inverter provides four safety functions, certified in accordance with EN 954-1 Cat. 3 and IEC 61508 SIL 2:

- Safe stop 1 (SS1)
- Safely limited speed (SLS)
- Safe brake control (SBC)
- Safe torque off (STO)

Innovative cooling concept and paint finish of electronic modules

The new cooling system and the paint finish for the electronic modules significantly increase the service life or useful life of the device. These features are based on the following principles:

- Disposal of all heat losses via an external heat sink
- Electronic modules not located in air duct
- Standardized convection cooling of Control Unit
- All cooling air from the fan is directed through the heat sink

STARTER drive/commissioning software

The STARTER drive/commissioning software supports the commissioning and maintenance of SINAMICS G120 inverters. The operator guidance combined with comprehensive, user-friendly functions for the relevant drive solution allow you to commission the device quickly and easily.

Benefits

- Modularity ensures flexibility for an advanced drive concept
 - Every development stage of a component can improve the existing drive system
 - Module replacement when system is running (hot swapping)
 - Pluggable terminals
 - The modules can be easily replaced, which makes the system extremely service friendly.
- The safety functions make it easier to integrate drives into safety-oriented machines or plants
- Capable of communicating via PROFINET or PROFIBUS with PROFIdrive Profil 4.0
 - Reduced number of interfaces
 - Plant-wide engineering
 - Easy to handle
- The innovative circuit design (bidirectional input rectifier with "pared-down" DC link) allows the kinetic energy of a load to be fed back into the supply system when Power Modules PM250 and PM260 are implemented. This feedback capability provides enormous potential for savings because generated energy no longer has to be converted into heat in a braking resistor
- Innovative SiC semiconductor technology ensures that when a PM260 Power Module is used, the inverter is more compact than a comparable standard inverter with an optional LC filter for the same output
- A new cooling concept and paint finish for the electronic modules increase robustness and service life
- Simple unit replacement and quick copying of parameters using the optional Basic Operator Panel or the optional MMC memory card
- Low-noise motor operation resulting from high pulse frequency
- Compact, space-saving construction
- Software parameters for easy adaptation to 50 Hz or 60 Hz motors (IEC or NEMA motors)
- 2/3-wire control (static/pulsated signals) for universal control via digital inputs
- Engineering and commissioning with uniform engineering tools such as SIZER, STARTER, and Drive ES: ensure rapid engineering and easy commissioning – STARTER is integrated in STEP 7 with Drive ES Basic with all the advantages of central data storage and totally integrated communication
- Certified worldwide for compliance with CE, UL, cUL, C-tick, Safety Integrated IEC 61508 SIL 2

Application

SINAMICS G120 is ideal

- as a universal drive in all industrial and commercial applications
- in the automotive, textiles, printing, and chemical industries
- for end-to-end applications, e.g. in conveyor systems

SINAMICS G120

Inverter chassis units 0.37 kW to 90 kW

0.37 kW to 90 kW

Design

The SINAMICS G120 inverter chassis units are modular frequency inverters for standard drives. Each SINAMICS G120 comprises two operative units – the Power Module and Control Unit.

Power Modules

The following Power Modules are available for SINAMICS G120 inverter chassis units:

PM240 Power Modules

PM240 Power Modules feature an integrated brake chopper and are designed for drives without energy recovery capability. Generator energy produced during braking is converted to heat via externally connected braking resistors.

PM250 Power Modules

PM250 Power Modules use an innovative circuit design which allows line-commutated energy recovery to the supply. This innovative circuit permits generator energy to be fed back into the supply system and therefore saves energy.

PM260 Power Modules

PM260 Power Modules also use an innovative circuit design which allows line-commutated energy recovery to the supply. This innovative circuit permits generator energy to be fed back into the supply system and, therefore, saves energy. The PM260 Power Modules also have an integrated sine-wave filter that limits the rate of rise of voltage and the capacitive charge/discharge currents usually associated with inverter operation.

Control Units

The following Control Units and an MMC memory card are available as accessories for SINAMICS G120 inverter chassis units:

CU240 Control Units

The Control Unit performs closed-loop control functions for the inverter. In addition to control functions, the Control Unit can also perform other tasks which can be adapted to the relevant application by parameterization. A number of Control Units are available in different versions:

- CU240S
- CU240S DP
- CU240S DP-F
- CU240S PN
- CU240S PN-F (available soon)
- CU240E (available soon)

MMC memory card

The parameter settings for an inverter can be stored on the MMC memory card. When the plant is serviced, it is immediately ready for use again after, for example, replacement of the frequency inverter and transfer of the memory card data. The associated slot is located on top of the Control Unit.

A large number of components for expanding the system is also available (e.g. line-side power components, DC-link components, load-side power components, and supplementary system components).

Line-side power components

The following line-side power components are available for SINAMICS G120 inverter chassis units:

Line filters

The Power Module complies with a higher radio interference class with one additional line filter.

Line reactors (for PM240 Power Modules only)

A line reactor is needed for high system fault levels, partly to protect the actual inverter against excessive harmonic currents, and thus against overload, and partly to limit the system perturbation to the permitted values.

Recommended line components

This is a recommendation for further line-side components, such as fuses and circuit-breakers (line-side components must be dimensioned in accordance with IEC standards). Further information about the listed fuses and circuit-breakers can be found in Catalogs LV 1 and LV 1 T.

DC link components

The following DC-link components are available for SINAMICS G120 inverter chassis units:

Braking resistors (for PM240 Power Modules only)

Excess power in the DC link is dissipated via the braking resistor. The braking resistors are designed for use with PM240 Power Modules. They are equipped with an integrated brake chopper (electronic switch).

Load-side power components

The following load-side power components are available for SINAMICS G120 inverter chassis units. This means that during operation with output reactors or LC filters or sine-wave filters, longer, shielded motor cables are possible and the motor service life can be increased:

Output reactors (for PM240 Power Modules only)

Output reactors reduce the voltage loading on the motor windings. At the same time, the capacitive charge/discharge currents, which place an additional load on the power section when long motor cables are used, are reduced.

LC filter and sine-wave filter (available soon)

The LC filter/sine-wave filter limits the rate of rise of voltage and the capacitive charge/discharge currents usually associated with converter operation. An output reactor is not required.

Design (continued)**Availability as base components**

The following line-side power components, DC-link components and load-side power components are designed as base components in the corresponding frame sizes:

	Size					
	FSA	FSB	FSC	FSD	FSE	FSF
Line-side power components						
Line filter class A	✓	–	–	–	–	–
Line filter class B	✓	✓	✓	–	–	–
Line reactors (for PM240 Power Modules only)	✓	✓	✓	✓	✓	–
DC link components						
Braking resistors (for PM240 Power Modules only)	✓	✓	–	–	–	–
Load-side power components						
Output reactors (for PM240 Power Modules only)	✓	✓	✓	–	–	–

Supplementary system components

The following supplementary system components are available for SINAMICS G120 inverter chassis units:

Basic Operator Panel BOP

The Basic Operator Panel BOP can be plugged onto the Control Unit and can be used to commission drives, monitor drives in operation and input individual parameter settings. The BOP also provides a function for quick copying of parameters.

PC inverter connection kit

For controlling and commissioning an inverter directly from a PC if the appropriate software (STARTER) has been installed. The STARTER commissioning tool is supplied with the PC inverter connection kit on CD-ROM.

Brake Relay

The Brake Relay allows the Power Module to be connected to an electromechanical motor brake, thereby allowing the motor brake to be driven directly by the Control Unit.

Safe Brake Relay

The Safe Brake Relay allows the Power Module to be connected to an electromechanical motor brake, allowing the brake to be directly and safely controlled by the Control Unit in accordance with EN 954-1, safety category 3 and IEC 61508 SIL 2.

Adapter for DIN rail attachment

The adapter for DIN rail attachment can be used to mount inverters of frame sizes FSA and FSB on DIN rails (2 units with a center-to-center distance of 100 mm).

Shield connection kit

The shield connection kit makes it easier to bond the shields of supply and control cables, offers mechanical strain relief and thus ensures optimum EMC performance.

NEMA1 mounting kit

The SINAMICS G120 inverter chassis units are designed to comply with type "UL OPEN". The NEMA1 mounting kit is required to obtain a type 1 NEMA housing compliant with NEMA1 directives (NEMA 250-2003).

Configuration

The following electronic configuration and engineering tools are available for SINAMICS G120 inverter chassis units:

SD configurator selection aid within the CA 01

The interactive catalog CA 01 – the offline mall of Siemens Automation and Drives (A&D) – contains over 100000 products with approximately 5 million potential drive system product variants. The SD configurator has been developed to facilitate selection of the correct motor and/or inverter from the wide spectrum of A&D SD products. The configurator is integrated in this catalog with the selection and configuration tools as a "selection help" on CD 2 "Configuring".

SIZER configuration tool

The SIZER PC tool provides an easy-to-use means of configuring the SINAMICS and MICROMASTER 4 drive family. It provides support when setting up the technologies involved in the hardware and firmware components required for a drive task. SIZER supports the complete configuration of the drive system, from simple individual drives to complex multi-axis applications.

STARTER drive/commissioning software

The STARTER drive/commissioning software provides menu-guided assistance with commissioning, optimization and diagnostics. STARTER is not only designed for use on SINAMICS drives but also for MICROMASTER4 units and frequency inverters for SIMATIC ET 200S FC distributed I/Os.

Drive ES engineering system

Drive ES is the engineering system used to integrate Siemens drive technology into the SIMATIC automation world easily, efficiently and cost-effectively in terms of communication, configuration and data management. The STEP 7 Manager user interface provides the basis for this procedure. A variety of software packages, i.e. Drive ES Basic, Drive ES SIMATIC and Drive ES PCS 7, is available for SINAMICS.

SINAMICS G120

Inverter chassis units 0.37 kW to 90 kW

0.37 kW to 90 kW

Technical specifications

Unless explicitly specified otherwise, the following technical specifications are valid for the following components of the SINAMICS G120 inverter chassis unit.

Mechanical data	
Vibratory load	
• Transport ¹⁾	Class 2M3 to EN 60068-2-6
• Operation	Class 3M4 to EN 60068-2-6 10 ... 58 Hz: Constant deflection 0.075 mm 58 ... 200 Hz: Constant acceleration = 9.81 m/s ² (1 g)
Shock load	
• Transport ¹⁾	Class 2M2 to EN 60068-2-27
• Operation	Class 3M4 to EN 60068-2-27 49 m/s ² (5 g)/30 ms
Ambient conditions	
Protection class	Class I (with protective conductor system) and class III (PELV) to EN 61800-5-1
Shock protection	according to EN 61800-5-1 when used properly
Permissible ambient and coolant temperature (air) during operation for line-side power components and Power Modules	
• High overload (HO)	-10 ... +50 °C (14 ... 122 °C) without derating, > 50 ... 60 °C, see derating characteristics
• Light overload (LO)	-10 ... +40 °C (14 ... 104 °C) without derating, > 40 ... 60 °C, see derating characteristics
Permissible ambient and coolant temperature (air) during operation for Control Units, additional system components and DC-link components	0 ... 50 °C with CU240S DP-F: 0 ... 45 °C up to 2000 m above sea level
Climatic ambient conditions	
• Storage ¹⁾	Class 1K3 to EN 60721-3-1 Temperature -25 ... +55 °C
• Transport ¹⁾	Class 2K4 to EN 60721-3-2 Temperature -40 ... +70 °C Max. air humidity 95% at 40 °C
• Operation	Class 3K5 to EN 60721-3-3 Condensation, splashwater and ice formation are not permitted (EN 60204, Part 1)
Environmental class/harmful chemical substances	
• Storage ¹⁾	Class 1C2 to EN 60721-3-1
• Transport ¹⁾	Class 2C2 to EN 60721-3-2
• Operation	Class 3C2 to EN 60721-3-3
Organic/biological influences	
• Storage ¹⁾	Class 1B1 to EN 60721-3-1
• Transport ¹⁾	Class 2B1 to EN 60721-3-2
• Operation	Class 3B1 to EN 60721-3-3
Degree of contamination	2 to EN 61800-5-1

Standards	
Standards conformance	UL, cUL, CE, c-tick
CE mark	To Low-Voltage Directive 73/23/EEC and Machinery Directive 89/37/EEC
EMC directive ²⁾	
• Frame sizes FSB to FSF with integrated line filter class A	Category C2 ³⁾ to EN 61800-3 (corresponds to class A to EN 55011)
• Frame size FSA without integrated line filter, with additional line filter class A	Category C2 ³⁾ to EN 61800-3 (corresponds to class A to EN 55011)
• Frame size FSA with additional line filter class A and with additional line filter class B	Category C2 ³⁾ to EN 61800-3 (corresponds to class B to EN 55011)
• Frame sizes FSB and FSC with additional line filter class A and with additional line filter class B	Category C2 ³⁾ to EN 61800-3 (corresponds to class B to EN 55011)
<p>Note: The EMC product standard EN 61800-3 does not apply directly to a frequency inverter but to a PDS (Power Drive System), which comprises the complete circuitry, motor and cables in addition to the inverter. The frequency inverters on their own do not generally require identification according to the EMC directive.</p>	

¹⁾ In transport packaging.

²⁾ For further, general information, see also SINAMICS G110 sections "Technical specifications" and "Compliance with standards".

³⁾ With shielded motor cable up to 25 m.

SINAMICS G120

Inverter chassis units 0.37 kW to 90 kW

CU240 Control Units

Overview



Example of CU240S DP-F Control Unit

The Control Unit performs closed-loop control functions for the inverter. In addition to control functions, the Control Unit can also perform other tasks which can be adapted to the relevant application by parameterization. A number of Control Units are available in different versions:

- CU240S
- CU240S DP
- CU240S DP-F
- CU240S PN

Selection and ordering data

Communication	Digital inputs Standard	Digital inputs Failsafe	Digital outputs	Encoder interfaces	Designation	Control Unit Order No.
Standard						
RS485/USS	9	–	3	1	CU240S	6SL3244-0BA20-1BA0
PROFIBUS DP	9	–	3	1	CU240S DP	6SL3244-0BA20-1PA0
PROFINET	9	–	3	1	CU240S PN	6SL3244-0BA20-1FA0
Failsafe for Safety Integrated						
PROFIBUS DP	6	2	3	1	CU240S DP-F	6SL3244-0BA21-1PA0

SINAMICS G120

Inverter chassis units 0.37 kW to 90 kW

CU240 Control Units

Design



Example: Control Unit CU240S DP without terminal cover, with plug-in terminals

Terminal No.	Signal	Features
Digital inputs (DI) – standard		
5 ... 8, 16, 17	DI0 ... DI5	Freely programmable (isolated) 5.5 mA/24 V
40 ... 42 (with CU240S, CU240S DP, and CU240S PN only)	DI6 ... DI8	Freely programmable (isolated) 5.5 mA/24 V
Digital inputs (DI) – failsafe (for CU240S DP-F only)		
60 ... 64 (with CU240S DP-F only)	FDI0A FDI0B FDI1A FDI1B	Failsafe digital inputs, 2 channels (redundant), freely programmable (isolated) 5.5 mA/24 V
Digital outputs (DO)		
18	DO0, NC	Relay output 1 NC contact (0.5 A, 30 V DC)
19	DO0, NO	Relay output 1 NO contact (0.5 A, 30 V DC)
20	DO0, COM	Relay output 1 Common contact (0.5 A, 30 V DC)
21	DO1, NO	Relay output 2 NO contact (0.5 A, 30 V DC)
22	DO1, COM	Relay output 2 Common contact (0.5 A, 30 V DC)
23	DO2, NC	Relay output 3 NC contact (0.5 A, 30 V DC)
24	DO2, NO	Relay output 3 NO contact (0.5 A, 30 V DC)
25	DO2, COM	Relay output 3 Common contact (0.5 A, 30 V DC)

Terminal No.	Signal	Features
Analog inputs (AI)		
3	AI0+	0 ... 10 V, -10 ... +10 V, 0/2 ... 10 V, or 0/4 ... 20 mA
4	AI0-	
10	AI1+	0 ... 10 V, 0 ... 20 mA
11	AI1-	
Analog outputs (AO)		
12	AO0+	Freely programmable (0/4 ... 20 mA, 0/2 ... 10 V with 500 W load)
13	AO0-	M (GND)
26	AO1+	Freely programmable (0/4 ... 20 mA with 500 W load)
27	AO1-	M (GND)
Encoder interface		
70	ENC AP	Encoder AP – channel A non-negating input
71	ENC AN	Encoder AN – channel A negating input
72	ENC BP	Encoder BP – channel B non-negating input
73	ENC BN	Encoder BN – channel B negating input
74	ENC ZP	Encoder ZP – zero pulse non-negating input
75	ENC ZN	Encoder ZN – zero pulse negating input
PTC/KTY interface		
14	PTC+	Positive PTC/KTY input
15	PTC-	Negative PTC/KTY input
Power supply		
33	ENC+ supply	Isolated encoder power supply (+24 V with 100 mA, +5 V with 300 mA or > 30 V input by user), configured via DIP switches
9	U 24 V	Isolated user power supply +24 V with 100 mA
28	U 0 V	Isolated encoder power supply and user reference voltage
1	+10 V	Non-isolated, stabilized 10 V power sup- ply for I/O – max. 10 mA
2	0 V	Power supply reference
31	+24 V	24 V power supply input
32	0 V	24 V power supply reference

SINAMICS G120

Inverter chassis units 0.37 kW to 90 kW

CU240 Control Units

Integration

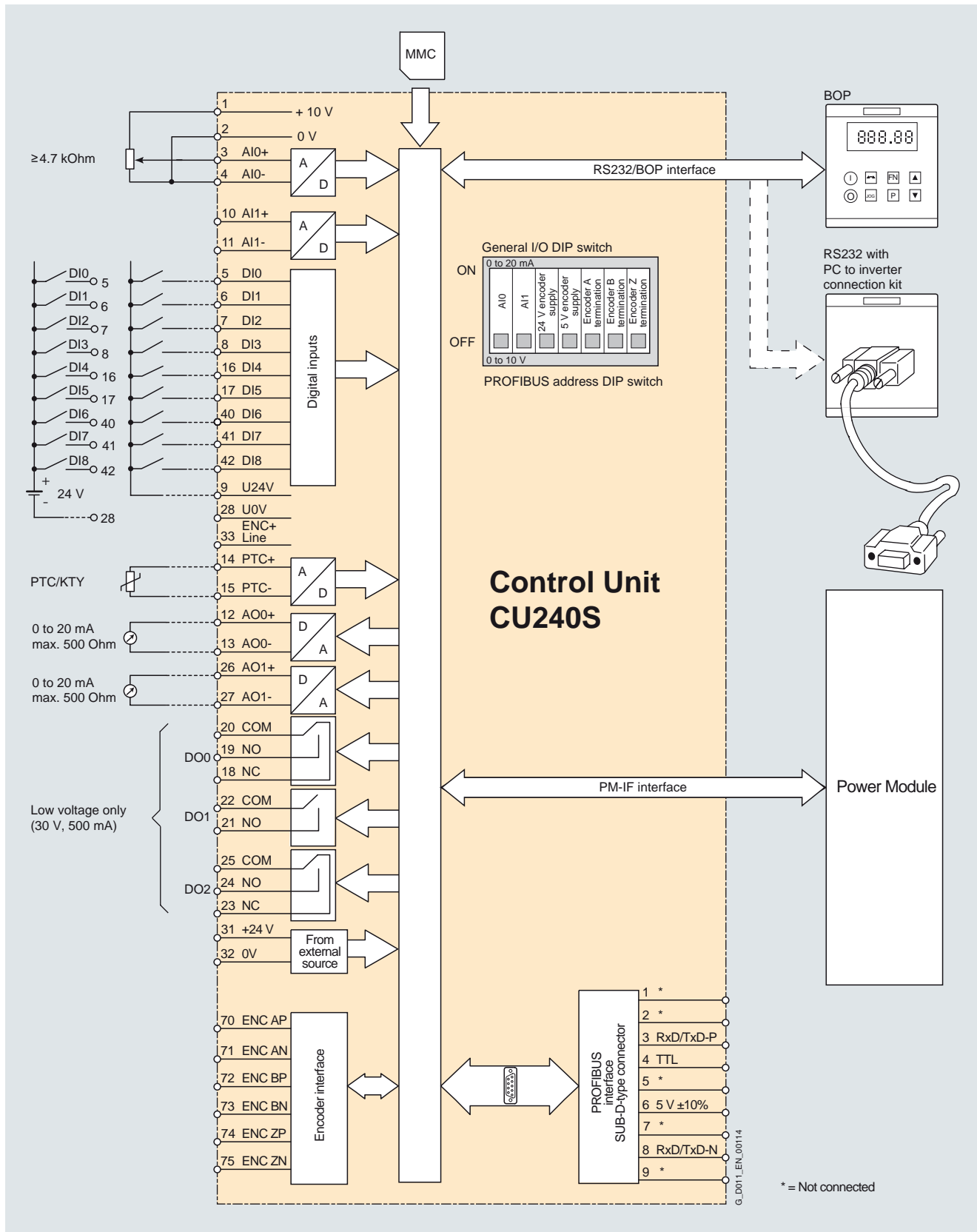

Connection diagram CU240S Control Unit

SINAMICS G120

Inverter chassis units 0.37 kW to 90 kW

CU240 Control Units

Integration (continued)

3

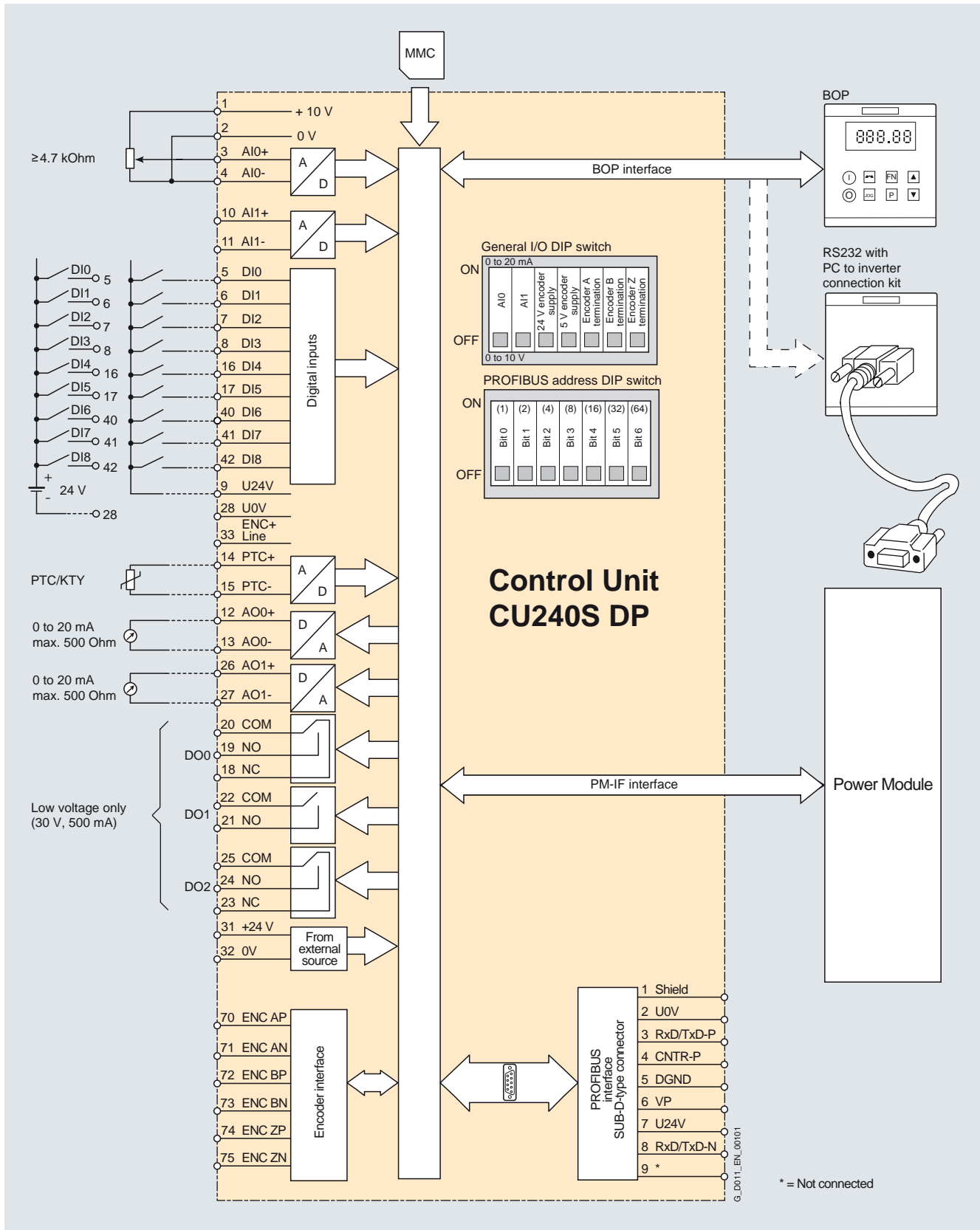

Connection diagram CU240S DP Control Unit

SINAMICS G120

Inverter chassis units 0.37 kW to 90 kW

CU240 Control Units

Integration (continued)

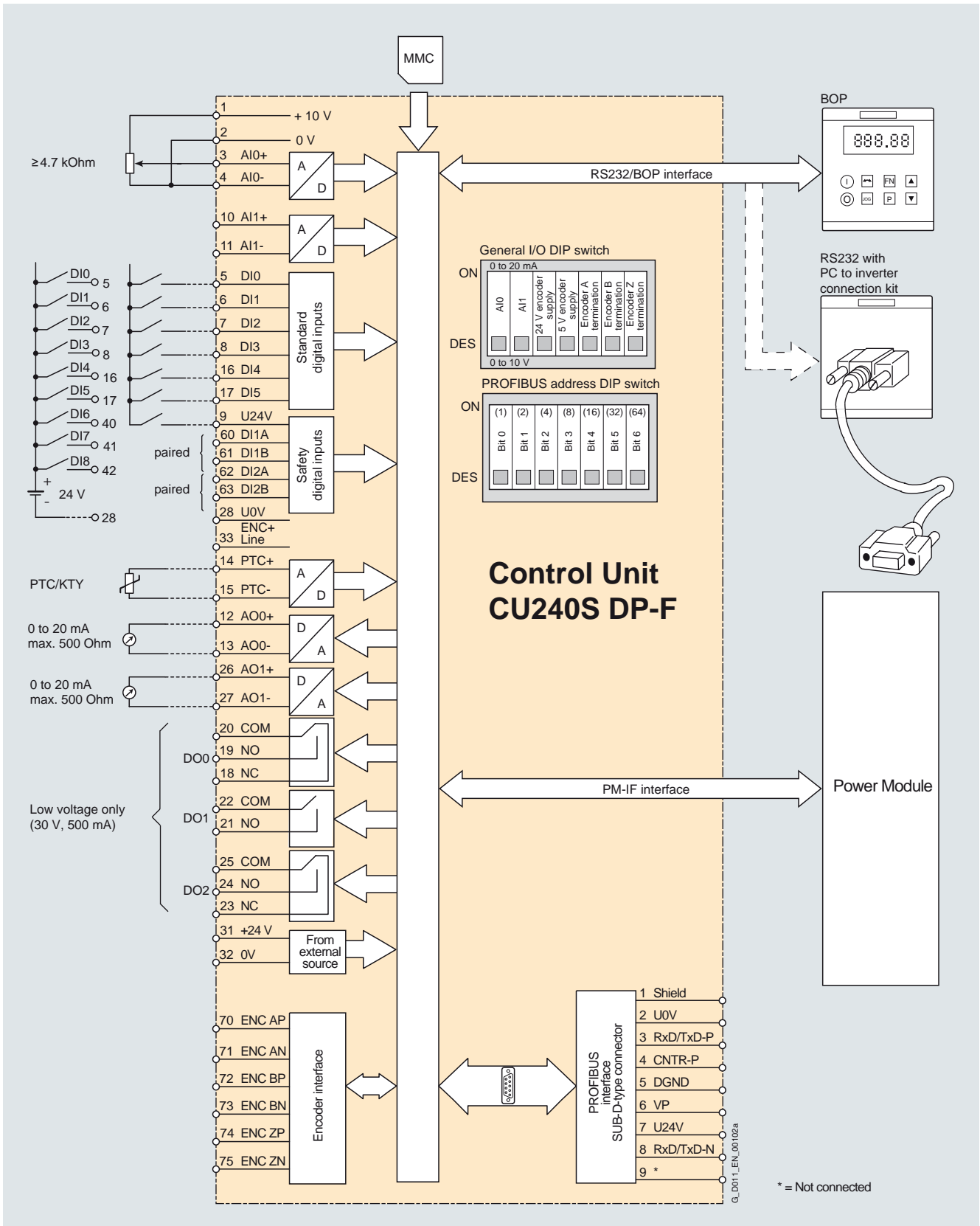

Connection diagram CU240S DP-F Control Unit

SINAMICS G120

Inverter chassis units 0.37 kW to 90 kW

CU240 Control Units

Integration (continued)

3

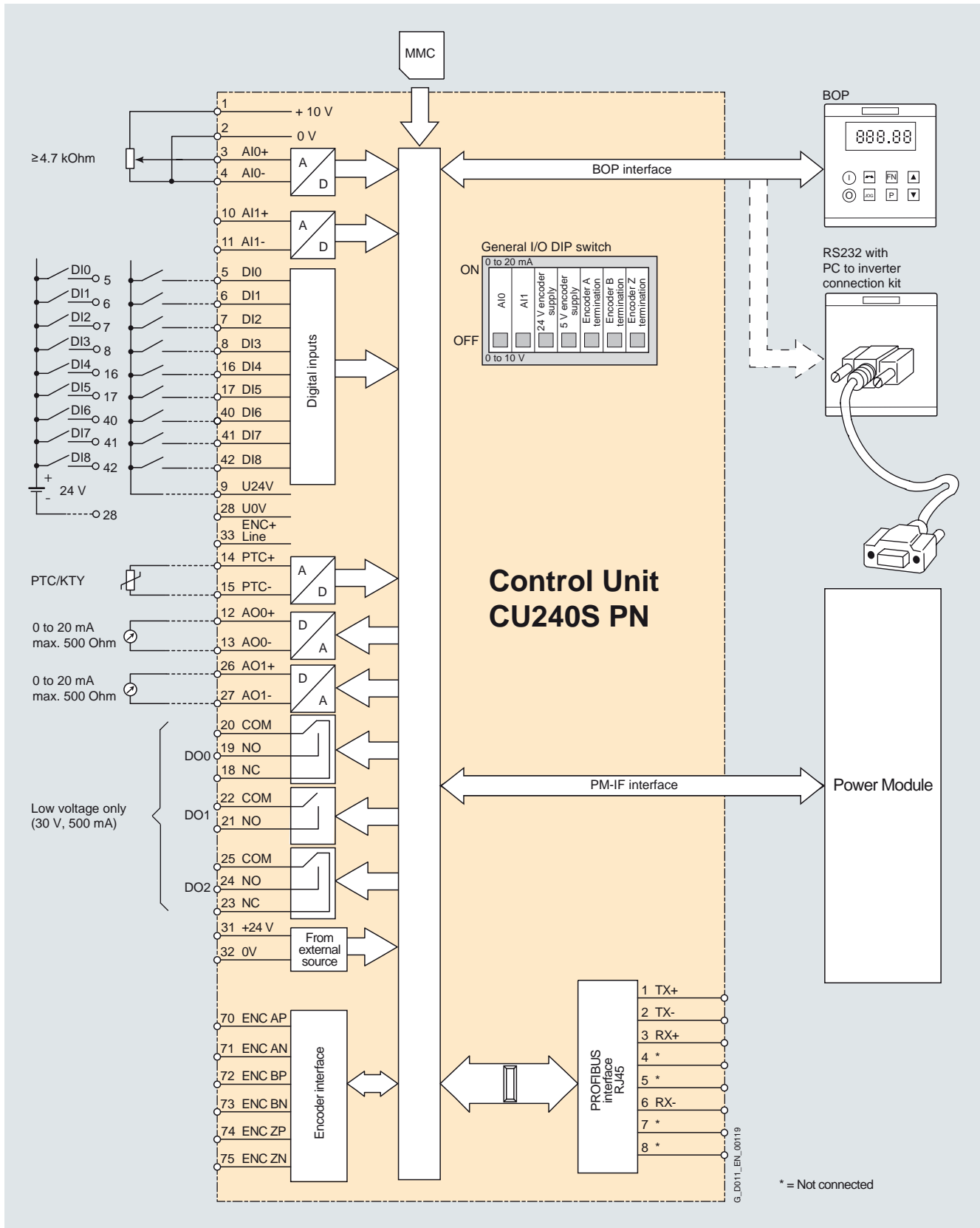

Connection diagram CU240S DP Control Unit

SINAMICS G120

Inverter chassis units 0.37 kW to 90 kW

CU240 Control Units

Technical specifications

	Control Unit CU240S 6SL3244-0BA20-1BA0	Control Unit CU240S DP 6SL3244-0BA20-1PA0	Control Unit CU240S DP-F 6SL3244-0BA21-1PA0	Control Unit CU240S PN 6SL3244-0BA20-1FA0
Electrical data				
Operating voltage	24 V DC via the Power Module or an external 24 V DC supply	24 V DC via the Power Module or an external 24 V DC supply	24 V DC via the Power Module or an external 24 V DC supply	24 V DC via the Power Module or an external 24 V DC supply
Power loss	< 40 W	< 40 W	< 40 W	< 40 W
Interfaces				
Digital inputs – standard	9	9	6	9
Digital inputs – failsafe	–	–	2	–
Digital outputs	3	3	3	3
Analog inputs	2	2	2	2
	Both analog inputs can be configured as supplementary digital inputs if an additional function is required. Switching thresholds: 0 → 1: Rated voltage 2 V 1 → 0: Rated voltage 0.8 V Analog inputs are protected against inputs in a voltage range of ± 30 V and have a common-mode voltage in the ± 15 V range.			
Analog outputs	2	2	2	2
	Analog outputs have short-circuit protection, but are not isolated. Maximum output voltage = 10 V in current mode, maximum output current = 20 mA in voltage mode. The reaction time should equal approximately 1 ms with a load of maximum 10 kΩ in voltage mode.			
Bus interface	RS485/USS	PROFIBUS DP	PROFIBUS DP, PROFIsafe	PROFINET
Encoder interfaces	1	1	1	1
PTC/KTY interface	✓	✓	✓	✓
Brake Relay interface/Safe Brake Relay interface (connection via Power Module)	✓	✓	✓	✓
MMC memory card slot	✓	✓	✓	✓
RS232/USS interface (connection via PC inverter connection kit)	✓	✓	✓	✓
Safety functions				
Integral safety functions to Category 3 of EN 954-1 and SIL2 of IEC 61508	–	–	<ul style="list-style-type: none"> • Safe Stop 1 (SS1) • Safely Limited Speed (SLS) • Safe Brake Control (SBC) • Safe Torque Off (STO) 	–
Open-loop and closed-loop control functions				
V/f linear/quadratic/parameterizable	✓	✓	✓	✓
V/f with flux current control (FCC)	✓	✓	✓	✓
Vector control, encoderless	✓	✓	✓	✓
Vector control with encoder	✓	✓	✓	✓
Torque control, encoderless	✓	✓	✓	✓
Torque control with encoder	✓	✓	✓	✓

SINAMICS G120

Inverter chassis units 0.37 kW to 90 kW

CU240 Control Units

Technical specifications (continued)

	Control Unit CU240S 6SL3244-0BA20-1BA0	Control Unit CU240S DP 6SL3244-0BA20-1PA0	Control Unit CU240S DP-F 6SL3244-0BA21-1PA0	Control Unit CU240S PN 6SL3244-0BA20-1FA0
Software functions				
Fixed frequencies	16, programmable	16, programmable	16, programmable	16, programmable
Signal interconnection with BICO technology	✓	✓	✓	✓
Automatic restart following line failure or operation fault	✓	✓	✓	✓
Positioning deceleration ramp	✓	✓	✓	✓
Slip compensation	✓	✓	✓	✓
Free function blocks (FFB) for logic and arithmetic operations	✓	✓	✓	✓
Ramp smoothing	✓	✓	✓	✓
3 switchable drive data sets	✓	✓	✓	✓
3 switchable command data sets (CDS) (manual/auto)	✓	✓	✓	✓
Flying restart	✓	✓	✓	✓
JOG	✓	✓	✓	✓
Technology controller (PID)	✓	✓	✓	✓
Thermal motor protection	✓	✓	✓	✓
Thermal inverter protection	✓	✓	✓	✓
Setpoint specification	✓	✓	✓	✓
Motor identification	✓	✓	✓	✓
Motor holding brake	✓	✓	✓	✓
V _{dcmax} controller	✓ (with PM240 only)	✓ (with PM240 only)	✓ (with PM240 only)	✓ (with PM240 only)
Kinetic buffering	✓ (with PM240 only)	✓ (with PM240 only)	✓ (with PM240 only)	✓ (with PM240 only)
Braking functions	✓ (with PM240 only)	✓ (with PM240 only)	✓ (with PM240 only)	✓ (with PM240 only)
<ul style="list-style-type: none"> • DC injection braking • Compound braking • Dynamic braking with integrated brake chopper 				
Mechanical specifications and environmental operating conditions				
Degree of protection	IP20	IP20	IP20	IP20
Signal cable cross-section				
<ul style="list-style-type: none"> • min. • max. 	0.05 mm ² (AWG30) 2 mm ² (AWG14)	0.05 mm ² (AWG30) 2 mm ² (AWG14)	0.05 mm ² (AWG30) 2 mm ² (AWG14)	0.05 mm ² (AWG30) 2 mm ² (AWG14)
Operating temperature	-10 ... +50 °C (14 ... 122 °F)	-10 ... +50 °C (14 ... 122 °F)	0 ... 45 °C (32 ... 113 °F)	-10 ... +50 °C (14 ... 122 °F)
Storage temperature	-40 ... +70 °C (-40 ... +158 °F)	-40 ... +70 °C (-40 ... +158 °F)	-40 ... +70 °C (-40 ... +158 °F)	-40 ... +70 °C (-40 ... +158 °F)
Relative humidity	< 95% RH, non-condensing	< 95% RH, non-condensing	< 95% RH, non-condensing	< 95% RH, non-condensing
Dimensions				
<ul style="list-style-type: none"> • Width • Height • Depth 	73 mm 177 mm 63 mm	73 mm 177 mm 63 mm	73 mm 177 mm 63 mm	73 mm 177 mm 63 mm
Weight, approx.	0.52 kg	0.52 kg	0.52 kg	0.52 kg

SINAMICS G120

Inverter chassis units 0.37 kW to 90 kW

Memory card for Control Units

Overview



The parameter settings for an inverter can be stored on the MMC memory card. When the plant is serviced, it is immediately ready for use again after, for example, replacement of the frequency inverter and transfer of the memory card data.

- Parameter settings can be written from the MMC memory card to the inverter or saved from the inverter to the MMC memory card.
- Up to 100 parameter sets can be stored.
- Supports standard commissioning without the use of additional commissioning tools (e.g. BOP and STARTER).
- How the MMC memory card is commissioned can be defined by the user (parameter p8458):
 - 0 = Parameter set 0 is never automatically downloaded from the MMC ("never")
 - 1 = Parameter set 0 is downloaded once after PowerOn ("once")
 - 2 = Parameter set 0 is always downloaded once after Power On ("always")

Note:
The MMC memory card is not required when the inverter is running.

Integration



Inserting the MMC memory card into the Control Unit



Control Unit with inserted MMC memory card

Selection and ordering data

	Order No.
MMC memory card	6SL3254-0AM00-0AA0

SINAMICS G120

Inverter chassis units 0.37 kW to 90 kW

PM240 Power Modules

Overview



PM240 Power Modules feature an integrated brake chopper to which an external braking resistor can be connected via terminals DCP/R1 and R2 (see DC-link components).

The DC-link capacitance of the DC link is such that the PM240 Power Module provides a sufficient control range for the DC-link voltage and is easily capable of handling applications such as kinetic buffering (maintenance of DC-link voltage through regenerative feedback to DC link of kinetic energy produced by the load) or controlled, safe deceleration after a power failure using kinetic energy produced by the load. Furthermore, several PM240 Power Modules can be electrically coupled by this method.

The PM240 Power Module is also designed for safety-sensitive applications. In conjunction with a Safety Control Unit, the drive can be turned into a Safety Integrated Drive (see Control Units).

The permissible cable lengths between inverter and motor are limited depending on cable type. Longer cables can be used if output reactors are connected (see load-side power components).

Line reactors are available for minimizing system perturbation (see line-side components).

Frame size FSA of the PM240 Power Module is available only without integrated line filter to class A. A base filter for compliance with class A and another for compliance with class B are, therefore, provided (see line-side power components).

Frame sizes FSB and FSC of the PM240 Power Module are available both with and without integrated line filter to class A. For compliance with class B, PM240 Power Modules with integrated line filter to class A must be fitted additionally with a base filter to class B (see line-side components).

Power Modules with integrated line filter to class A are suitable only for connection to TN supply systems. Power Modules without integrated line filter can be connected to grounded (TN, TT) and non-grounded (IT) supply systems.

SINAMICS G120

Inverter chassis units 0.37 kW to 90 kW

PM240 Power Modules

Integration

PM240 Power Modules communicate with the Control Unit via the PM-IF interface.

PM240 Power Modules feature the following interfaces as standard:

- PM-IF interface for connection of the PM240 Power Module and Control Unit. The PM240 Power Module also supplies power to the Control Unit by means of an integrated power pack
- Terminals DCP/R1 and R2 for connection of an external braking resistor
- Motor connection made with screw terminals or screw studs
- Drive circuit for the Brake Relay or the Safe Brake Relay for controlling a holding brake
- 2 x PE (protective earth) connections

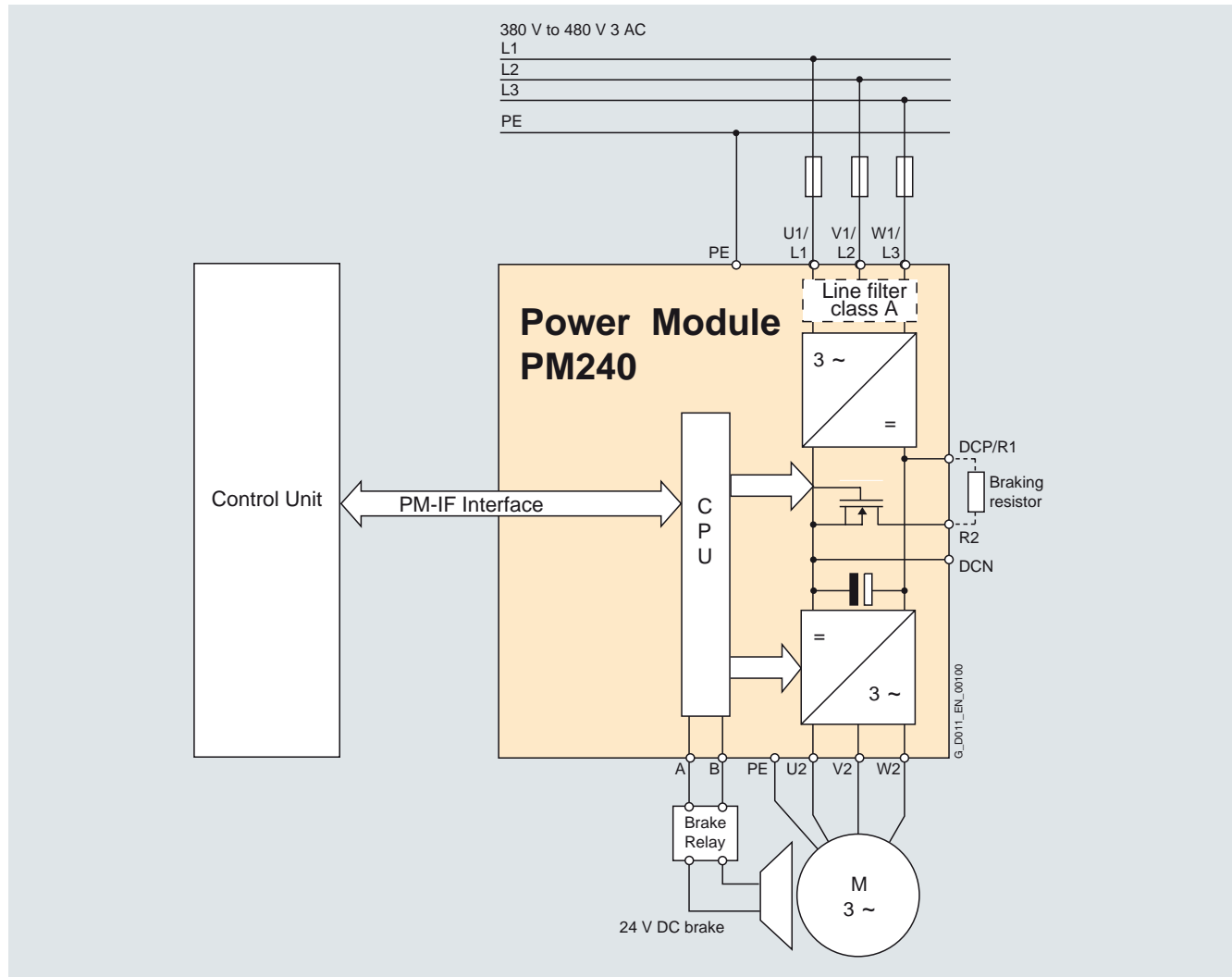

Connection diagram for PM240 Power Module with or without integrated line filter class A

Availability as base components

Many system components for PM240 Power Modules are designed as base components, that is, the component is mounted on the baseplate and the PM240 Power Module above it in a space-saving construction. Up to two base components can be mounted above one another.

The following line-side power components, DC-link components and load-side power components are designed as base components in the corresponding frame sizes:

	Frame size					
	FSA	FSB	FSC	FSD	FSE	FSF
Line-side power components						
Line filter class A	✓	–	–	–	–	–
Line filter class B	✓	✓	✓	–	–	–
Line reactors	✓	✓	✓	✓	✓	–
DC link components						
Braking resistors	✓	✓	–	–	–	–
Load-side power components						
Output reactors (motor reactors)	✓	✓	✓	–	–	–

SINAMICS G120

Inverter chassis units 0.37 kW to 90 kW

PM240 Power Modules

Integration (continued)

The following diagram shows the basic layout of a PM240 Power Module with a line reactor as base component. The line-side reactors are equipped with terminals and the reactors at the Power Module end with a pre-assembled cable. In the final installation position, the mains terminals are at the top on frame sizes FSA to FSC, and at the bottom on frame sizes FSD to FSE.

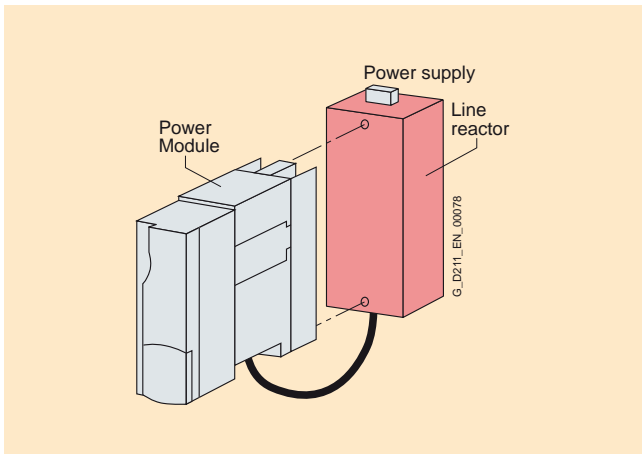

Basic layout of a PM240 Power Module with line reactor as base component

If a line filter is installed in addition to the line reactor on frame size FSA, the components must be arranged as shown in the diagram below. In this case, the line connection is below.

Power Modules of frame size FSB and higher are available with integrated line filters (an external line filter is not required in this case).

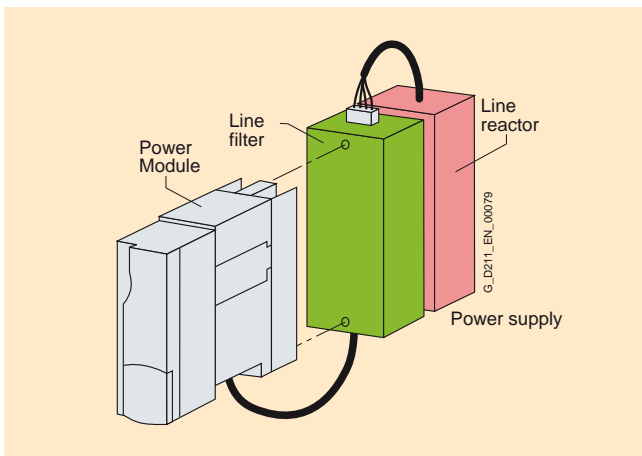

Power Module PM240 frame size FSA with line reactor and line filter

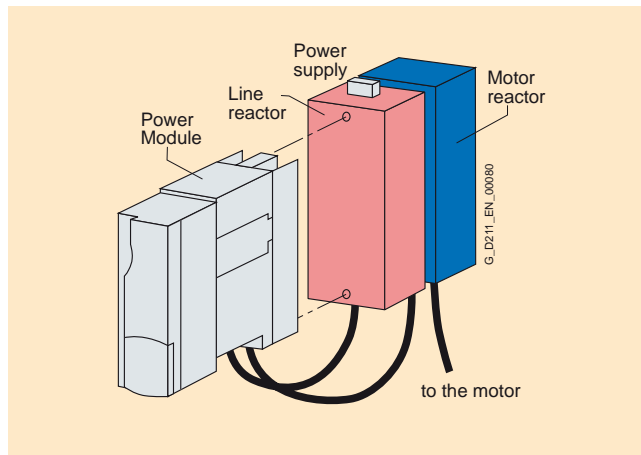

Power Module PM240 frame size FSA with line reactor and motor reactor

For configurations involving more than two base-type system components, e.g. line reactor + motor reactor + braking resistor, individual components must be mounted to the side of the Power Modules. In this instance, the line and motor reactors must be installed under the Power Module and the braking resistor to the side.

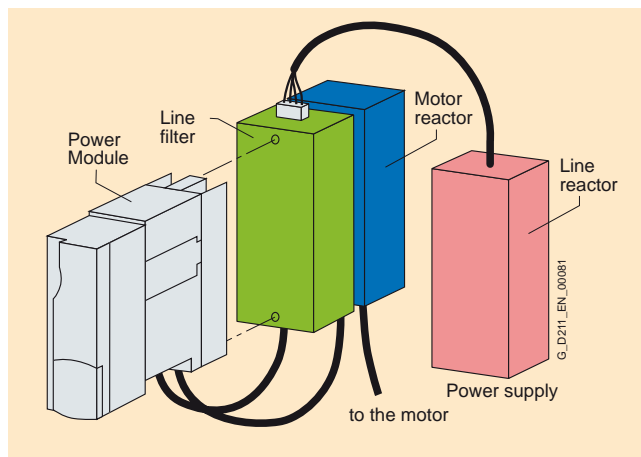

SINAMICS G120

Inverter chassis units 0.37 kW to 90 kW

PM240 Power Modules

Technical specifications

General technical data

PM240 Power Modules	
Line operating voltage	380 ... 480 V 3 AC $\pm 10\%$
Line requirements	no restriction
Line short circuit voltage u_k	
Input frequency	47 ... 63 Hz
Output frequency	
• Control type V/f	0 ... 650 Hz
• Control type Vector	0 ... 200 Hz
Pulse frequency	4 kHz (standard), for higher pulse frequencies, see derating data
Power factor	0.95
Inverter efficiency	95 ... 97%
Control factor	93%
Overload capability	
• High overload (HO)	1.5 \times rated output current (i.e. 150% overload) for 57 s with a cycle time of 300 s 2 \times rated output current (i.e. 200% overload) for 3 s with a cycle time of 300 s
• Light overload (LO)	1.1 \times rated output current (i.e. 110% overload) for 57 s with a cycle time of 300 s 1.5 \times rated output current (i.e. 150% overload) for 3 s with a cycle time of 300 s
Electromagnetic compatibility	Optional line filter class A or B to EN 55011 available
Possible braking methods	<ul style="list-style-type: none"> • DC injection braking • Compound braking • Dynamic braking with integrated brake chopper
Degree of protection	IP20
Operating temperature	
• High overload (HO)	-10 ... +50 °C (14 ... 122°F) without derating, > 50 ... 60 °C, see derating characteristics
• Light overload (LO)	-10 ... +40 °C (14 ... 104 °F) without derating, > 40 ... 60 °C, see derating characteristics
Storage temperature	-40 ... +70 °C (-40 ... +158 °F)
Relative humidity	< 95% RH, non-condensing
Cooling	Internal ventilator, power units with increased air cooling by built-in fans
Installation altitude	Up to 1000 m above sea level without derating, > 1000 m see derating characteristics
Standard SCCR (Short Circuit Current Rating) ¹⁾	FSA, FSB, FSC: 10 kA FSD, FSE, FSF: 42 kA
Protective functions	<ul style="list-style-type: none"> • Undervoltage • Overvoltage • Overload • Ground fault • Short-circuit • Stall prevention • Motor blocking protection • Motor overtemperature • Inverter overtemperature • Parameter interlock
Standards conformance	UL, cUL, CE, c-tick
CE mark	To Low-Voltage Directive 73/23/EEC and Machinery Directive 98/37/EEC

¹⁾ Applies to industrial control cabinet installations to NEC article 409/UL 508A. For further information, visit us on the Internet at:
<http://support.automation.siemens.com/WW/view/en/23995621>

SINAMICS G120

Inverter chassis units 0.37 kW to 90 kW

PM240 Power Modules

Technical specifications (continued)

Line voltage 380 ... 480 V 3 AC		PM240 Power Modules				
Without integrated line filter		6SL3224- 0BE13-7UA0	6SL3224- 0BE15-5UA0	6SL3224- 0BE17-5UA0	6SL3224- 0BE21-1UA0	6SL3224- 0BE21-5UA0
Rated output current $I_{rated}^{1)}$	A	1.3	1.7	2.2	3.1	4.1
Base load current $I_L^{1)}$	A	1.3	1.7	2.2	3.1	4.1
Base load current $I_H^{2)}$	A	1.3	1.7	2.2	3.1	4.1
Output current I_{max}	A	2.6	3.4	4.4	6.2	8.2
Rated power based on I_L	kW	0.37	0.55	0.75	1.1	1.5
Rated power based on I_H	kW	0.37	0.55	0.75	1.1	1.5
Rated pulse frequency	kHz	4	4	4	4	4
Efficiency η		0.95	0.95	0.95	0.95	0.95
Power loss	kW	0.1	0.1	0.1	0.1	0.11
Cooling air requirement	m ³ /s	0.005	0.005	0.005	0.005	0.005
Sound pressure level	dB(A)	< 45	< 45	< 45	< 45	< 45
24 V DC power supply for the Control Unit	A	1	1	1	1	1
Rated input current ³⁾						
• with line reactor	A	1.4	1.8	2.3	3.2	4.3
• without line reactor	A	1.7	2.1	2.6	3.9	4.9
Max. length of cable to braking resistor	m	15	15	15	15	15
Line supply connection U1/L1, V1/L2, W1/L3		Screw terminals	Screw terminals	Screw terminals	Screw terminals	Screw terminals
• Conductor cross-section	mm ²	1 ... 2.5	1 ... 2.5	1 ... 2.5	1 ... 2.5	1 ... 2.5
Motor connection U2, V2, W2		Screw terminals	Screw terminals	Screw terminals	Screw terminals	Screw terminals
• Conductor cross-section	mm ²	1 ... 2.5	1 ... 2.5	1 ... 2.5	1 ... 2.5	1 ... 2.5
DC link connection, connection for braking resistor DCP/R1, DCN, R2		Screw terminals	Screw terminals	Screw terminals	Screw terminals	Screw terminals
• Conductor cross-section	mm ²	1 ... 2.5	1 ... 2.5	1 ... 2.5	1 ... 2.5	1 ... 2.5
PE connection		On housing with M4 screw	On housing with M4 screw	On housing with M4 screw	On housing with M4 screw	On housing with M4 screw
Motor cable length ⁴⁾ , max.						
• Shielded	m	50	50	50	50	50
• Unshielded	m	100	100	100	100	100
Degree of protection		IP20	IP20	IP20	IP20	IP20
Dimensions						
• Width	mm	73	73	73	73	73
• Height	mm	173	173	173	173	173
• Depth						
- without Control Unit	mm	145	145	145	145	145
- with Control Unit	mm	210	210	210	210	210
Frame size		FSA	FSA	FSA	FSA	FSA
Weight, approx.	kg	1.1	1.1	1.1	1.1	1.1

¹⁾ The rated output current I_{rated} and the base load current I_L are based on the loading for light overload (light overload LO).

²⁾ The base load current I_H is based on the loading for high overload (high overload HO).

³⁾ The input current depends on the motor load and line impedance. The input currents apply for a load representing the rated power (based on I_{rated}) for a line impedance corresponding to $u_k = 1\%$. These current values without line reactor are quoted on the rating plate of the Power Module.

⁴⁾ Max. motor cable length 25 m (shielded) for PM240 Power Modules with integrated line filter to maintain the limit values of EN 61800-3 Category C2.

SINAMICS G120

Inverter chassis units 0.37 kW to 90 kW

PM240 Power Modules

Technical specifications (continued)

Line voltage 380 ... 480 V 3 AC		PM240 Power Modules				
Without integrated line filter		6SL3224- 0BE22-2UA0	6SL3224- 0BE23-0UA0	6SL3224- 0BE24-0UA0	6SL3224- 0BE25-5UA0	6SL3224- 0BE27-5UA0
With integrated line filter		6SL3224- 0BE22-2UA0	6SL3224- 0BE23-0AA0	6SL3224- 0BE24-0AA0	6SL3224- 0BE25-5AA0	6SL3224- 0BE27-5AA0
Rated output current $I_{rated}^{1)}$	A	5.9	7.7	10.2	18	25
Base load current $I_L^{1)}$	A	5.9	7.7	10.2	18	25
Base load current $I_H^{2)}$	A	5.9	7.7	10.2	13.2	29
Output current I_{max}	A	11.8	15.4	20.4	26.4	38
Rated power based on I_L	kW	2.2	3	4	7.5	11
Rated power based on I_H	kW	2.2	3	4	5.5	7.5
Rated pulse frequency	kHz	4	4	4	4	4
Efficiency η		0.95	0.95	0.95	0.95	0.95
Power loss	kW	0.14	0.16	0.18	0.24	0.30
Cooling air requirement	m ³ /s	0.024	0.024	0.024	0.055	0.055
Sound pressure level	dB(A)	< 50	< 50	< 50	< 60	< 60
24 V DC power supply for the Control Unit	A	1	1	1	1	1
Rated input current ³⁾						
• with line reactor	A	6.1	8	10.4	18.7	26
• without line reactor	A	7.6	10.2	13.4	21.9	31.5
Max. length of cable to braking resistor	m	15	15	15	15	15
Line supply connection U1/L1, V1/L2, W1/L3		Screw terminals	Screw terminals	Screw terminals	Screw terminals	Screw terminals
• Conductor cross-section	mm ²	1 ... 6	1 ... 6	1 ... 6	2.5 ... 10	2.5 ... 10
Motor connection U2, V2, W2		Screw terminals	Screw terminals	Screw terminals	Screw terminals	Screw terminals
• Conductor cross-section	mm ²	1 ... 6	1 ... 6	1 ... 6	2.5 ... 10	2.5 ... 10
DC link connection, connec- tion for braking resistor DCP/R1, DCN, R2		Screw terminals	Screw terminals	Screw terminals	Screw terminals	Screw terminals
• Conductor cross-section	mm ²	1 ... 6	1 ... 6	1 ... 6	2.5 ... 10	2.5 ... 10
PE connection		On housing with M5 screw	On housing with M5 screw	On housing with M5 screw	On housing with M5 screw	On housing with M5 screw
Motor cable length ⁴⁾ , max.						
• Shielded	m	50	50	50	50	50
• Unshielded	m	100	100	100	100	100
Degree of protection		IP20	IP20	IP20	IP20	IP20
Dimensions						
• Width	mm	153	153	153	189	189
• Height	mm	270	270	270	334	334
• Depth						
- without Control Unit	mm	165	165	165	185	185
- with Control Unit	mm	230	230	230	250	250
Frame size		FSB	FSB	FSB	FSC	FSC
Weight, approx.	kg	4	4	4	7	7

¹⁾ The rated output current I_{rated} and the base load current I_L are based on the loading for light overload (light overload LO).

²⁾ The base load current I_H is based on the loading for high overload (high overload HO).

³⁾ The input current depends on the motor load and line impedance. The input currents apply for a load representing the rated power (based on I_{rated}) for a line impedance corresponding to $u_k = 1\%$. These current values without line reactor are quoted on the rating plate of the Power Module.

⁴⁾ Max. motor cable length 25 m (shielded) for PM240 Power Modules with integrated line filter to maintain the limit values of EN 61800-3 Category C2.

SINAMICS G120

Inverter chassis units 0.37 kW to 90 kW

PM240 Power Modules

Technical specifications (continued)

Line voltage 380 ... 480 V 3 AC		PM240 Power Modules				
Without integrated line filter		6SL3224-0BE31-1UA0	6SL3224-0BE31-5UA0	6SL3224-0BE31-8UA0	6SL3224-0BE32-2UA0	6SL3224-0BE33-0UA0
With integrated line filter		6SL3224-0BE31-1AA0	6SL3224-0BE31-5AA0	6SL3224-0BE31-8AA0	6SL3224-0BE32-2AA0	6SL3224-0BE33-0AA0
Rated output current $I_{rated}^{1)}$	A	32	38	45	60	75
Base load current $I_L^{1)}$	A	32	38	45	60	75
Base load current $I_H^{2)}$	A	26	32	38	45	60
Output current I_{max}	A	52	64	76	90	124
Rated power based on I_L	kW	15	18.5	22	30	37
Rated power based on I_H	kW	11	15	18.5	22	30
Rated pulse frequency	kHz	4	4	4	4	4
Efficiency η		0.95	0.95	0.95	0.95	0.95
Power loss	kW	0.4	0.4	0.5	0.7	1
Cooling air requirement	m ³ /s	0.055	0.055	0.055	0.055	2 x 0.055
Sound pressure level	dB(A)	< 60	< 60	< 60	< 61	< 60
24 V DC power supply for the Control Unit	A	1	1	1	1	1
Rated input current ³⁾						
• with line reactor	A	33	40	47	63	78
• without line reactor	A	39	46	53	72	88
Max. length of cable to braking resistor	m	15	15	15	15	15
Line supply connection U1/L1, V1/L2, W1/L3		Screw terminals	M6 screw studs	M6 screw studs	M6 screw studs	M6 screw studs
• Conductor cross-section	mm ²	2.5 ... 10	10 ... 35	10 ... 35	10 ... 35	10 ... 35
Motor connection U2, V2, W2		Screw terminals	M6 screw studs	M6 screw studs	M6 screw studs	M6 screw studs
• Conductor cross-section	mm ²	2.5 ... 10	10 ... 35	10 ... 35	10 ... 35	10 ... 35
DC link connection, connection for braking resistor DCP/R1, DCN, R2		Screw terminals	M6 screw studs	M6 screw studs	M6 screw studs	M6 screw studs
• Conductor cross-section	mm ²	2.5 ... 10	10 ... 35	10 ... 35	10 ... 35	10 ... 35
PE connection		On housing with M5 screw	On housing with M6 screw	On housing with M6 screw	On housing with M6 screw	On housing with M6 screw
Motor cable length ⁴⁾ , max.						
• Shielded	m	50	50	50	50	50
• Unshielded	m	100	100	100	100	100
Degree of protection		IP20	IP20	IP20	IP20	IP20
Dimensions						
• Width	mm	189	275	275	275	275
• Height						
- without integrated filter	mm	334	419	419	419	499
- with integrated filter	mm	334	512	512	512	635
• Depth						
- without Control Unit	mm	185	204	204	204	204
- with Control Unit	mm	250	260	260	260	260
Frame size		FSC	FSD	FSD	FSD	FSE
Weight, approx.						
• without integrated filter	kg	7	15.9	15.9	15.9	19.8
• with integrated filter	kg	7	19.3	19.3	19.3	27.1

¹⁾ The rated output current I_{rated} and the base load current I_L are based on the loading for light overload (light overload LO).

²⁾ The base load current I_H is based on the loading for high overload (high overload HO).

³⁾ The input current depends on the motor load and line impedance. The input currents apply for a load representing the rated power (based on I_{rated}) for a line impedance corresponding to $u_k = 1\%$. These current values without line reactor are quoted on the rating plate of the Power Module.

⁴⁾ Max. motor cable length 25 m (shielded) for PM240 Power Modules with integrated line filter to maintain the limit values of EN 61800-3 Category C2.

SINAMICS G120

Inverter chassis units 0.37 kW to 90 kW

PM240 Power Modules

Technical specifications (continued)

Line voltage 380 ... 480 V 3 AC		PM240 Power Modules			
Without integrated line filter		6SL3224-0BE33-7UA0	6SL3224-0BE34-5UA0	6SL3224-0BE35-5UA0	6SL3224-0BE37-5UA0
With integrated line filter		6SL3224-0BE33-7AA0	6SL3224-0BE34-5AA0	6SL3224-0BE35-5AA0	6SL3224-0BE37-5AA0
Rated output current $I_{rated}^{1)}$	A	90	110	145	178
Base load current $I_L^{1)}$	A	90	110	145	178
Base load current $I_H^{2)}$	A	75	90	110	145
Output current I_{max}	A	150	180	220	290
Rated power based on I_L	kW	45	55	75	90
Rated power based on I_H	kW	37	45	55	75
Rated pulse frequency	kHz	4	4	4	4
Efficiency η		0.95	0.95	0.95	0.95
Power loss	kW	1.3	1.5	2	2.4
Cooling air requirement	m ³ /s	2 × 0.055	0.15	0.15	0.15
Sound pressure level	dB(A)	< 62	< 60	< 60	< 65
24 V DC power supply for the Control Unit	A	1	1	1	1
Rated input current ³⁾					
• with line reactor	A	94	115	151	186
• without line reactor	A	105	129	168	204
Max. length of cable to braking resistor	m	15	15	15	15
Line supply connection U1/L1, V1/L2, W1/L3		M6 screw studs	M8 screw studs	M8 screw studs	M8 screw studs
• Max. conductor cross-section	mm ²	10 ... 35	1 × 120 or 2 × 50	1 × 120 or 2 × 50	1 × 120 or 2 × 50
Motor connection U2, V2, W2		M6 screw studs	M8 screw studs	M8 screw studs	M8 screw studs
• Max. conductor cross-section	mm ²	10 ... 35	1 × 120 or 2 × 50	1 × 120 or 2 × 50	1 × 120 or 2 × 50
DC link connection, connection for braking resistor DCP/R1, DCN, R2		M6 screw studs	M8 screw studs	M8 screw studs	M8 screw studs
• Max. conductor cross-section	mm ²	10 ... 35	1 × 120 or 2 × 50	1 × 120 or 2 × 50	1 × 120 or 2 × 50
PE connection		On housing with M6 screw	On housing with M8 screw	On housing with M8 screw	On housing with M8 screw
Motor cable length ⁴⁾ , max.					
• Shielded	m	50	50	50	50
• Unshielded	m	100	100	100	100
Degree of protection		IP20	IP20	IP20	IP20
Dimensions					
• Width	mm	275	350	350	350
• Height					
- without integrated filter	mm	499	634	634	634
- with integrated filter	mm	635	934	934	934
• Depth					
- without Control Unit	mm	204	316	316	316
- with Control Unit	mm	260	372	372	372
Frame size		FSE	FSF	FSF	FSF
Weight, approx.					
• without integrated filter	kg	19.8	50.7	50.7	50.7
• with integrated filter	kg	27.1	66.7	66.7	66.7

¹⁾ The rated output current I_{rated} and the base load current I_L are based on the loading for light overload (light overload LO).

²⁾ The base load current I_H is based on the loading for high overload (high overload HO).

³⁾ The input current depends on the motor load and line impedance. The input currents apply for a load representing the rated power (based on I_{rated}) for a line impedance corresponding to $u_k = 1\%$. These current values without line reactor are quoted on the rating plate of the Power Module.

⁴⁾ Max. motor cable length 25 m (shielded) for PM240 Power Modules with integrated line filter to maintain the limit values of EN 61800-3 Category C2.

SINAMICS G120

Inverter chassis units 0.37 kW to 90 kW

PM240 Power Modules

Selection and ordering data

Rated output ¹⁾		Rated output current ²⁾		Power based on the base load current ³⁾		Base load current ³⁾	Frame size	SINAMICS G120 Power Module PM240 without integrated line filter	SINAMICS G120 Power Module PM240 with integrated line filter class A
kW	hp	A	kW	hp	A				
380 ... 480 V 3 AC									
0.37	0.50	1.3	0.37	0.50	1.3	FSA	6SL3224-0BE13-7UA0	–	
0.55	0.75	1.7	0.55	0.75	1.7	FSA	6SL3224-0BE15-5UA0	–	
0.75	1.0	2.2	0.75	1.0	2.2	FSA	6SL3224-0BE17-5UA0	–	
1.1	1.5	3.1	1.1	1.5	3.1	FSA	6SL3224-0BE21-1UA0	–	
1.5	2.0	4.1	1.5	2.0	4.1	FSA	6SL3224-0BE21-5UA0	–	
2.2	3.0	5.9	2.2	3.0	5.9	FSB	6SL3224-0BE22-2UA0	6SL3224-0BE22-2AA0	
3.0	4.0	7.7	3.0	4.0	7.7	FSB	6SL3224-0BE23-0UA0	6SL3224-0BE23-0AA0	
4.0	5.0	10.2	4.0	5.0	10.2	FSB	6SL3224-0BE24-0UA0	6SL3224-0BE24-0AA0	
7.5	10	18	5.5	7.5	13.2	FSC	6SL3224-0BE25-5UA0	6SL3224-0BE25-5AA0	
11.0	15	25	7.5	10	19	FSC	6SL3224-0BE27-5UA0	6SL3224-0BE27-5AA0	
15.0	20	32	11.0	15	26	FSC	6SL3224-0BE31-1UA0	6SL3224-0BE31-1AA0	
18.5	25	38	15.0	20	32	FSD	6SL3224-0BE31-5UA0	6SL3224-0BE31-5AA0	
22	30	45	18.5	25	38	FSD	6SL3224-0BE31-8UA0	6SL3224-0BE31-8AA0	
30	40	60	22	30	45	FSD	6SL3224-0BE32-2UA0	6SL3224-0BE32-2AA0	
37	50	75	30	40	60	FSE	6SL3224-0BE33-0UA0	6SL3224-0BE33-0AA0	
45	60	90	37	50	75	FSE	6SL3224-0BE33-7UA0	6SL3224-0BE33-7AA0	
55	75	110	45	60	90	FSF	6SL3224-0BE34-5UA0	6SL3224-0BE34-5AA0	
75	100	145	55	75	110	FSF	6SL3224-0BE35-5UA0	6SL3224-0BE35-5AA0	
90	125	178	75	100	145	FSF	6SL3224-0BE37-5UA0	6SL3224-0BE37-5AA0	

¹⁾ Rated output based on the rated output current I_{rated} . The rated output current I_{rated} is based on the loading for light overload (light overload LO).

²⁾ The rated output current I_{rated} is based on the loading for light overload (light overload LO). These current values are quoted on the rating plate of the Power Module.

³⁾ The base load current I_H is based on the loading for high overload (high overload HO).

SINAMICS G120

Inverter chassis units 0.37 kW to 90 kW

PM240 Power Modules

3

Characteristic curves

Derating data

Pulse frequency

Rated output at 400 V 3 AC		Rated output current in A at a switching frequency of						
kW	hp	4 kHz	6 kHz	8 kHz	10 kHz	12 kHz	14 kHz	16 kHz
0.37	0.50	1.3	1.1	0.9	0.8	0.7	0.6	0.5
0.55	0.75	1.7	1.4	1.2	1.0	0.9	0.8	0.7
0.75	1.0	2.2	1.9	1.5	1.3	1.1	1.0	0.9
1.1	1.5	3.1	2.6	2.2	1.9	1.6	1.4	1.2
1.5	2.0	4.1	3.5	2.9	2.5	2.1	1.8	1.6
2.2	3.0	5.9	5.0	4.1	3.5	3.0	2.7	2.4
3.0	4.0	7.7	6.5	5.4	4.6	3.9	3.5	3.1
4.0	5.0	10.2	8.7	7.1	6.1	5.1	4.6	4.1
7.5	10	18.0	16.2	13.3	11.4	9.5	8.6	7.6
11.0	15	25.0	22.1	18.2	15.6	13.0	11.7	10.4
15.0	20	32.0	27.2	22.4	19.2	16.0	14.4	12.8
18.5	25	38.0	32.3	26.6	22.8	19.0	17.1	15.2
22.0	30	45.0	38.3	31.5	27.0	22.5	20.3	18.0
30.0	40	62.0	52.7	43.4	37.2	31.0	27.9	24.8
37.0	50	75.0	63.8	52.5	45.0	37.5	33.8	30.0
45.0	60	90.0	76.5	63.0	54.0	45.0	40.5	36.0
55.0	75	110.0	93.5	77.0	66.0	55.0	49.5	44.0
75.0	100	145.0	123.3	101.5	87.0	72.5	65.3	58.0
90.0	125	178.0	151.3	124.6	–	–	–	–

Ambient temperature

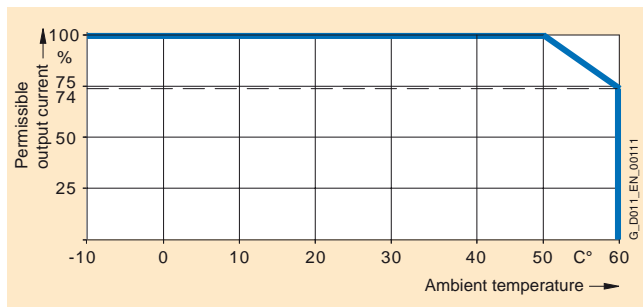

High overload (HO)

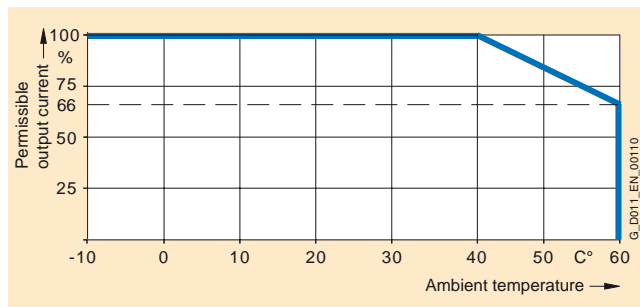

Light overload (LO)

Installation altitude

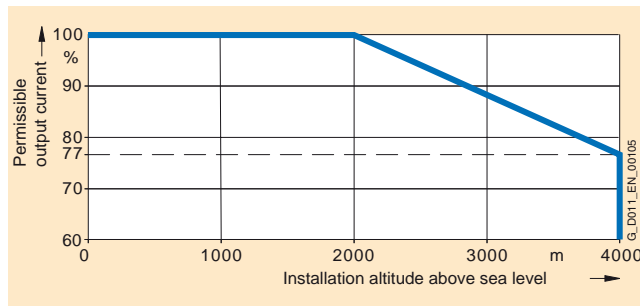
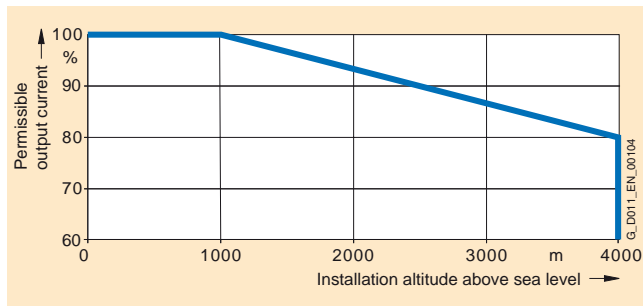

SINAMICS G120

Inverter chassis units 0.37 kW to 90 kW

PM240 Power Modules

Dimensional drawings

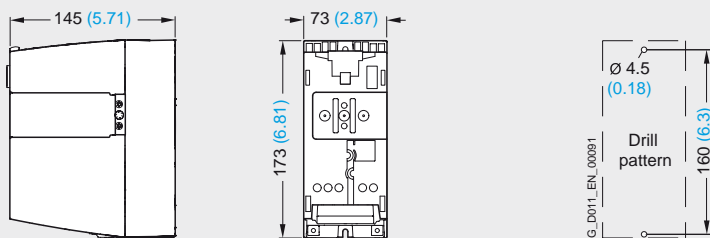

Power Module PM240 frame size FSA

Fixing with 2 M4 studs, 2 M4 nuts,
2 M4 washers

Tightening torque: 2.5 Nm (22.1 lbf-in)

Ventilation clearance required at top and bottom:
100 mm (3.94 inches)

Ventilation clearance required at sides: 30 mm (1.18 inches)

When the Control Unit is plugged in, the mounting depth increases by 65 mm (2.56 inches) and the total depth by 14 mm (0.55 inches).

All dimensions in mm (values in brackets are in inches).

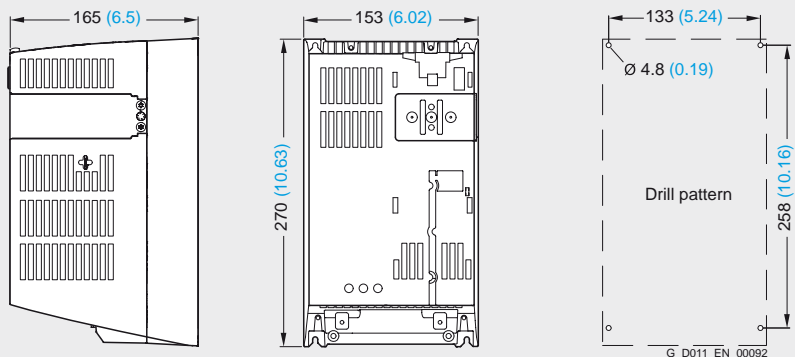

Power Module PM240 frame size FSB

Fixing with 4 M4 studs, 4 M4 nuts, 4 M4 washers

Tightening torque: 2.5 Nm (22.1 lbf-in)

Ventilation clearance required at top and bottom:
100 mm (3.94 inches)

Ventilation clearance required at sides: 40 mm (1.57 inches)

When the Control Unit is plugged in, the mounting depth increases by 65 mm (2.56 inches).

All dimensions in mm (values in brackets are in inches).

SINAMICS G120

Inverter chassis units 0.37 kW to 90 kW

PM240 Power Modules

Dimensional drawings (continued)

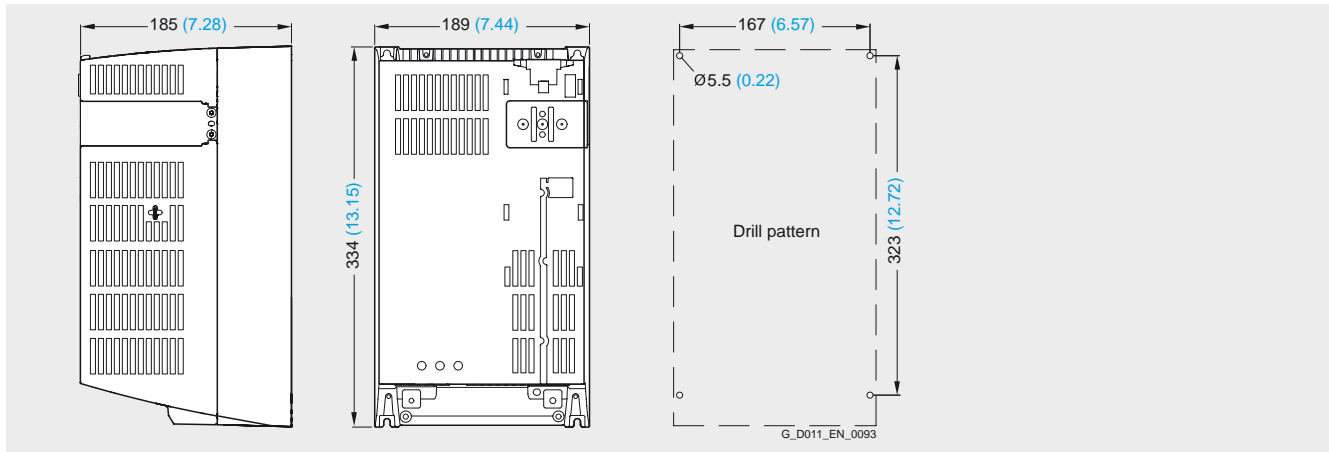

Power Module PM240 frame size FSC

Fixing with 4 M5 studs, 4 M5 nuts, 4 M5 washers

Tightening torque: 2.5 Nm (22.1 lbf-in)

Ventilation clearance required at top and bottom:
100 mm (3.94 inches)

Ventilation clearance required at sides: 50 mm (1.97 inches)

When the Control Unit is plugged in, the mounting depth increases by 65 mm (2.56 inches).

All dimensions in mm (values in brackets are in inches).

SINAMICS G120

Inverter chassis units 0.37 kW to 90 kW

PM240 Power Modules

Dimensional drawings (continued)

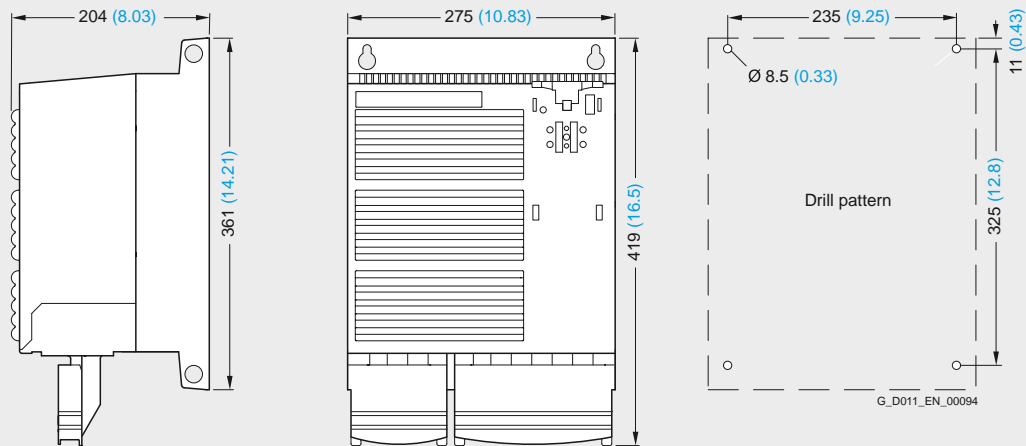

Power Module PM240 frame size FSD without line filter

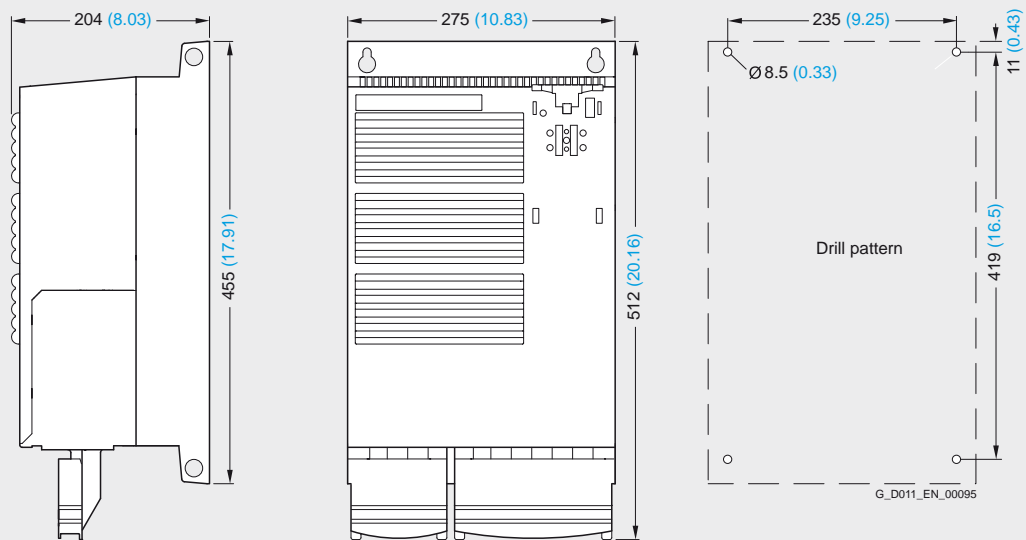

Power Module PM240 frame size FSD with integrated line filter class A

Fixing with 4 M6 studs, 4 M6 nuts, 4 M6 washers

Tightening torque: 6 Nm (53 lbf-in)

Ventilation clearance required at top and bottom:
300 mm (11.81 inches)

Ventilation clearance required at front: 28 mm (1.1 inches)

When the Control Unit is plugged in, the mounting depth increases by 56 mm (2.2 inches).

All dimensions in mm (values in brackets are in inches).

SINAMICS G120

Inverter chassis units 0.37 kW to 90 kW

PM240 Power Modules

Dimensional drawings (continued)

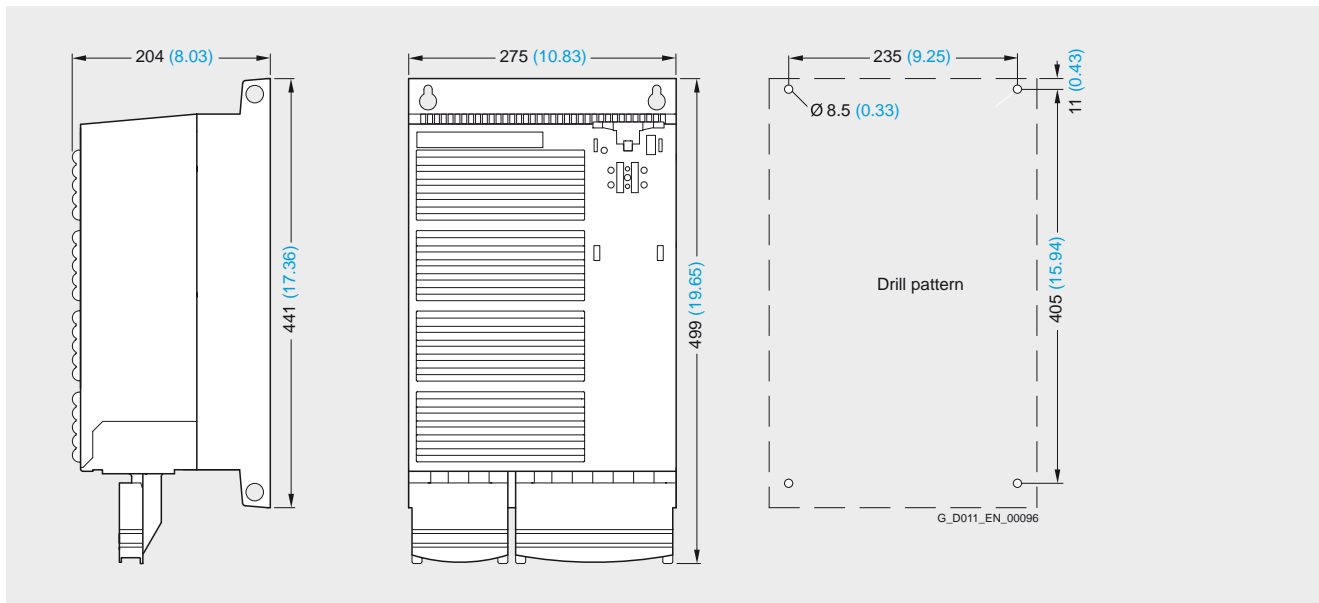

Power Module PM240 frame size FSE without line filter

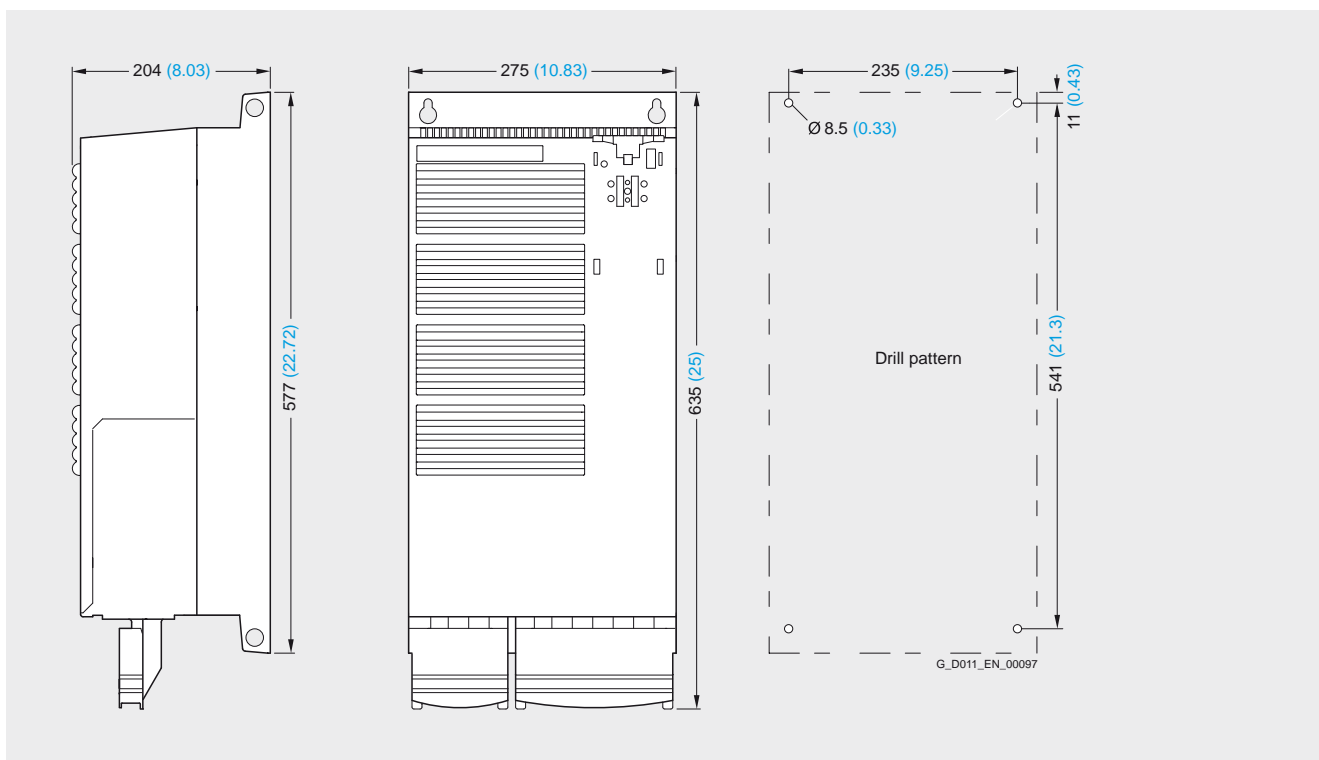

Power Module PM240 frame size FSE with integrated line filter class A

Fixing with 4 M6 studs, 4 M6 nuts, 4 M6 washers

Tightening torque: 6 Nm (53 lbf-in)

Ventilation clearance required at top and bottom:
300 mm (11.81 inches)

Ventilation clearance required at front: 28 mm (1.1 inches)

When the Control Unit is plugged in, the mounting depth increases by 56 mm (2.2 inches).

All dimensions in mm (values in brackets are in inches).

SINAMICS G120

Inverter chassis units 0.37 kW to 90 kW

PM240 Power Modules

Dimensional drawings (continued)

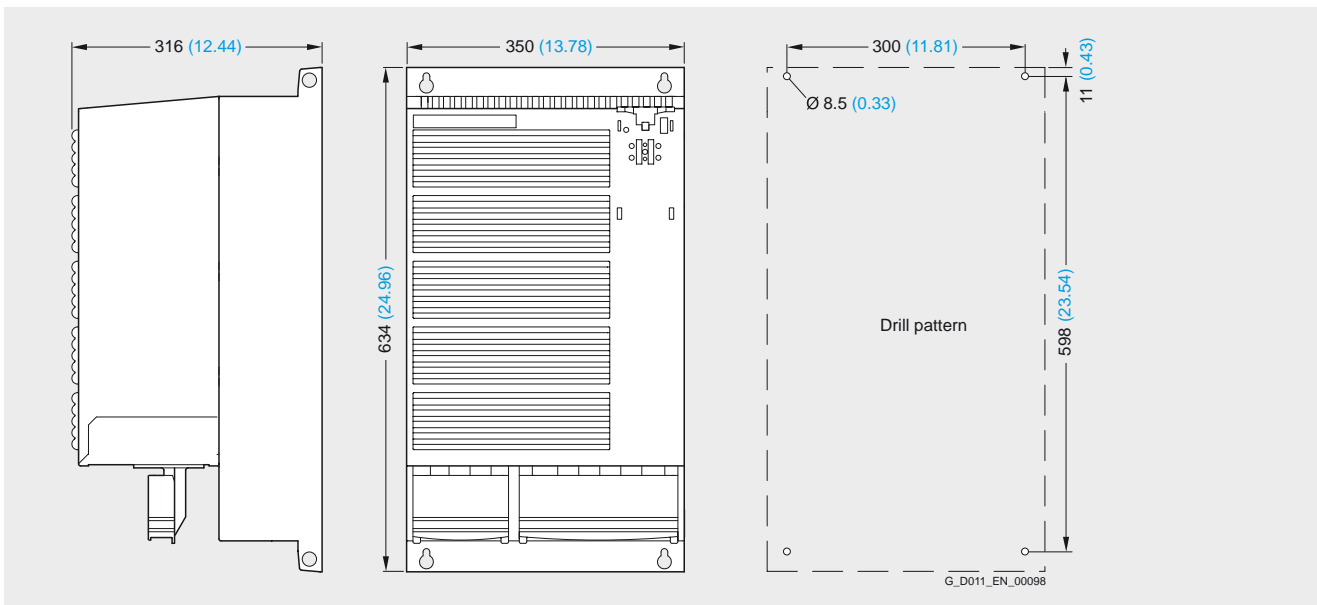

Power Module PM240 frame size FSF without line filter

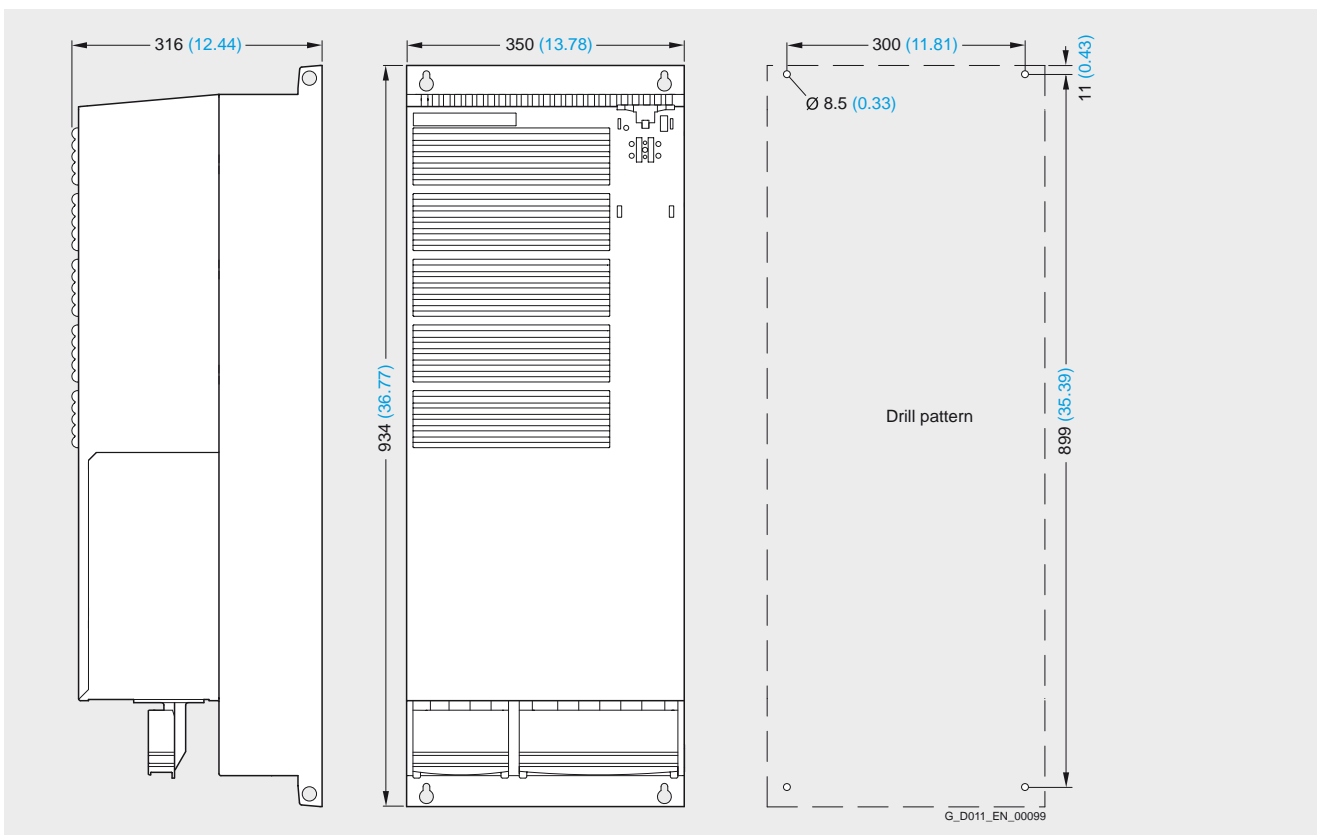

Power Module PM240 frame size FSF with integrated line filter class A

Fixing with 4 M8 studs, 4 M8 nuts, 4 M8 washers

Tightening torque: 13 Nm (115 lbf-in)

Ventilation clearance required at top and bottom:
350 mm (13.78 inches)

Ventilation clearance required at front: 28 mm (1.1 inches)

When the Control Unit is plugged in, the mounting depth increases by 56 mm (2.2 inches).

All dimensions in mm (values in brackets are in inches).

SINAMICS G120

Inverter chassis units 0.37 kW to 90 kW

PM250 Power Modules

Overview



The regenerative feedback capability of the PM250 Power Module in generating mode (electronic braking) means that energy is returned to the supply system and not destroyed in a braking resistor. This saves space in the control cabinet, time-consuming dimensioning of the braking resistor as well as the wiring. Generated heat is also reduced in the control cabinet.

An innovative circuit design reduces supply harmonics. There is no need to use an optional line reactor at the supply infeed. This saves space and costs for engineering and procurement.

The PM250 Power Module is also designed for safety-sensitive applications. In conjunction with a Safety Control Unit, the drive can be turned into a Safety Integrated Drive (see Control Units).

The permissible cable lengths between inverter and motor are limited depending on cable type. Longer cables can be used if output reactors are connected (see load-side power components).

For frame size FSC of Power Module PM250 with an integral line filter of class A, an additional base filter of class B is available for achieving class B (see line-side power components).

The PM250 Power Modules with integrated line filter to class A are suitable only for connection to TN supply systems.

SINAMICS G120

Inverter chassis units 0.37 kW to 90 kW

PM250 Power Modules

Integration

PM250 Power Modules communicate with the Control Unit via the PM-IF interface.

PM250 Power Modules feature the following interfaces as standard:

- PM-IF interface for connection of the PM250 Power Module and Control Unit. The PM250 Power Module also supplies power to the Control Unit by means of an integrated power pack

- Motor connection made with screw terminals or screw studs
- Drive circuit for the Brake Relay or the Safe Brake Relay for controlling a holding brake
- 2 x PE (protective earth) connections

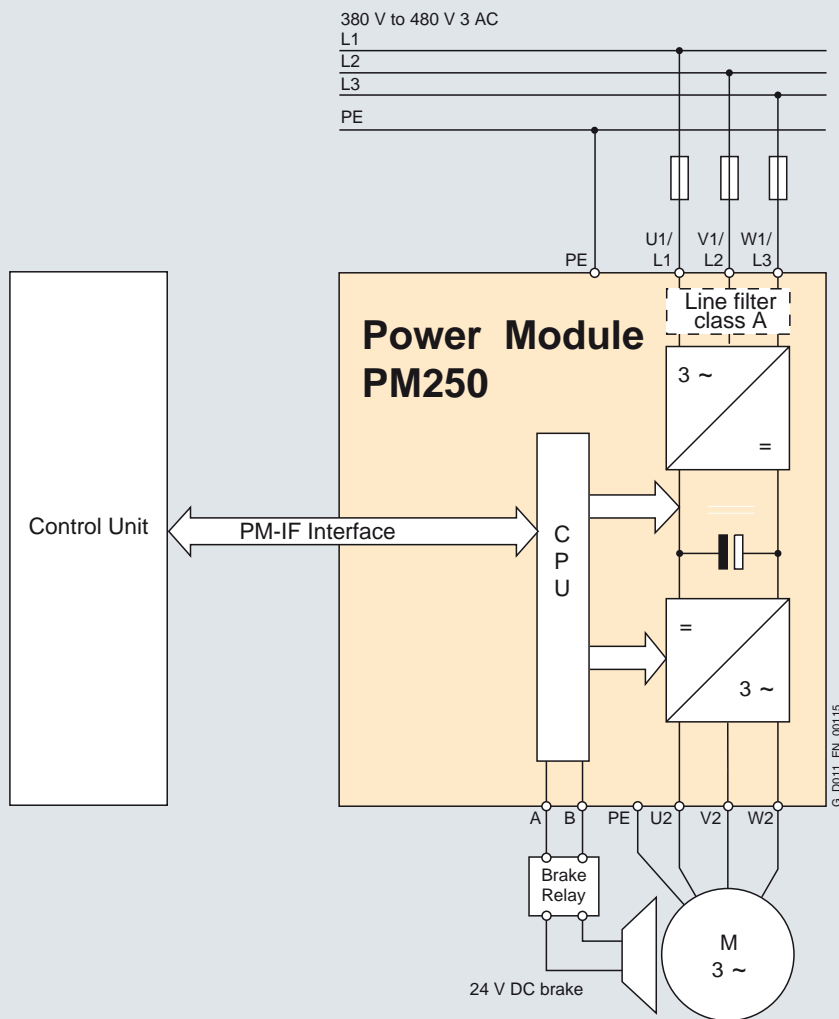

Connection diagram for PM250 Power Module with integrated line filter class A

SINAMICS G120

Inverter chassis units 0.37 kW to 90 kW

PM250 Power Modules

Integration (continued)

Availability as base components

Many system components for PM250 Power Modules are designed as base components, i.e. the component is mounted on the baseplate and the PM250 Power Module above it in a space-saving construction. Up to two base components can be mounted above one another.

The following line-side power components, DC-link components and load-side power components are designed as base components in the corresponding frame sizes:

	Frame size			
	FSC	FSD	FSE	FSF
Line-side power components				
Line filter class B	✓	–	–	–
Line reactors	Line reactors must not be used with PM250 Power Modules!			
Load-side power components				
Output reactors (motor reactors)	✓	–	–	–

The following diagram shows the basic layout of a PM250 Power Module with additional line filter class B as base component.

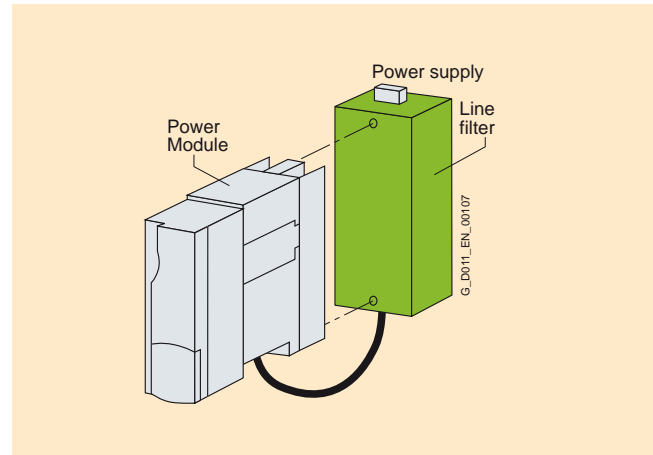

Basic layout of a PM250 Power Module with line filter class B as base component

The following example shows the structure for two base components:

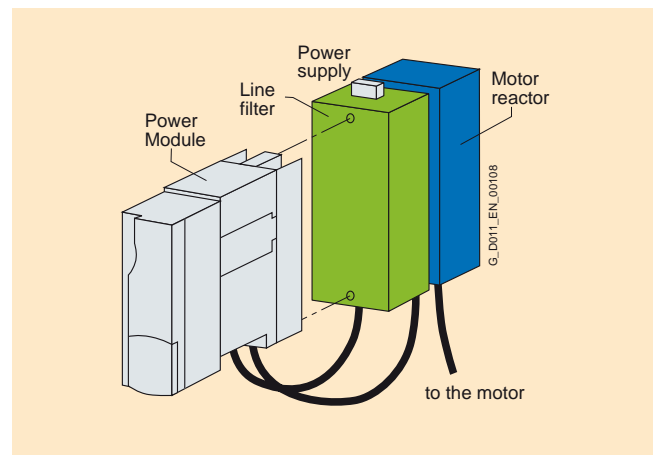

SINAMICS G120

Inverter chassis units 0.37 kW to 90 kW

PM250 Power Modules

Technical specifications

General technical data

	PM250 Power Modules
Line operating voltage	380 ... 480 V 3 AC $\pm 10\%$
Line requirements	$\leq 1\%$
Line short circuit voltage u_k	
Input frequency	47 ... 63 Hz
Output frequency	
• Control type V/f	0 ... 650 Hz
• Control type Vector	0 ... 200 Hz
Pulse frequency	4 kHz (standard), for higher pulse frequencies, see derating data
Power factor	0.95
Inverter efficiency	95 ... 97%
Control factor	87%
Overload capability	
• High overload (HO)	1.5 x rated output current (i.e. 150% overload) for 57 s with a cycle time of 300 s 2 x rated output current (i.e. 200% overload) for 3 s with a cycle time of 300 s
• Light overload (LO)	1.1 x rated output current (i.e. 110% overload) for 57 s with a cycle time of 300 s 1.5 x rated output current (i.e. 150% overload) for 3 s with a cycle time of 300 s
Electromagnetic compatibility	Integral line filter class A; optional line filter class B compliant with EN 55011 available
Possible braking methods	Regenerative feedback in generating mode
Degree of protection	IP20
Operating temperature	
• High overload (HO)	-10 ... +5 0°C (14 ... 122°F) without derating, > 50 ... 60 °C, see derating characteristics
• Light overload (LO)	-10 ... +40 °C (14 ... 104 °F) without derating, > 40 ... 60 °C, see derating characteristics
Storage temperature	-40 ... +70 °C (-40 ... +158 °F)
Relative humidity	< 95% RH, non-condensing
Cooling	Internal ventilator, power units with increased air cooling by built-in fans
Installation altitude	Up to 1000 m above sea level without derating, > 1000 m see derating characteristics
Standard SCCR (Short Circuit Current Rating) ¹⁾	FSC: 10 kA FSD, FSE, FSF: 42 kA
Protective functions	<ul style="list-style-type: none"> • Undervoltage • Overvoltage • Overload • Ground fault • Short-circuit • Stall prevention • Motor blocking protection • Motor overtemperature • Inverter overtemperature • Parameter interlock
Standards conformance	UL, cUL, CE, c-tick
CE mark	To Low-Voltage Directive 73/23/EEC and Machinery Directive 98/37/EEC

¹⁾ Applies to industrial control cabinet installations to NEC article 409/UL 508A. For further information, visit us on the Internet at: <http://support.automation.siemens.com/WW/view/en/23995621>

SINAMICS G120

Inverter chassis units 0.37 kW to 90 kW

PM250 Power Modules

Technical specifications (continued)

Line voltage 380 ... 480 V 3 AC		PM250 Power Modules				
		6SL3225-0BE25-5AA0		6SL3225-0BE27-5AA0		6SL3225-0BE31-1AA0
With integrated line filter						
Rated output current $I_{rated}^{1)}$	A	18	25	32		
Base load current $I_L^{1)}$	A	18	25	32		
Base load current $I_H^{2)}$	A	13.2	19	26		
Output current I_{max}	A	26.4	38	52		
Rated power based on I_L	kW	7.5	11	15		
Rated power based on I_H	kW	5.5	7.5	11		
Rated pulse frequency	kHz	4	4	4		
Efficiency η		0.95	0.95	0.95		
Power loss	kW	available soon	available soon	available soon		
Cooling air requirement	m ³ /s	0.038	0.038	0.038		
Sound pressure level	dB(A)	available soon	available soon	available soon		
24 V DC power supply for the Control Unit	A	1	1	1		
Rated input current ³⁾	A	18	25	32		
Input current based on $I_H^{3)}$	A	13.2	19	26		
Line supply connection U1/L1, V1/L2, W1/L3		Screw terminals	Screw terminals	Screw terminals		
• Conductor cross-section	mm ²	2.5 ... 10	2.5 ... 10	2.5 ... 10		
Motor connection U2, V2, W2		Screw terminals	Screw terminals	Screw terminals		
• Conductor cross-section	mm ²	2.5 ... 10	2.5 ... 10	2.5 ... 10		
PE connection		On housing with M5 screw	On housing with M5 screw	On housing with M5 screw		
Motor cable length, max.						
• Shielded	m	25	25	25		
• Unshielded	m	100	100	100		
Degree of protection		IP20	IP20	IP20		
Dimensions						
• Width	mm	189	189	189		
• Height	mm	334	334	334		
• Depth						
- without Control Unit	mm	185	185	185		
- with Control Unit	mm	250	250	250		
Frame size		FSC	FSC	FSC		
Weight, approx.	kg	7.5	7.5	7.5		

¹⁾ The rated output current I_{rated} and the base load current I_L are based on the loading for light overload (light overload LO).

²⁾ The base load current I_H is based on the loading for high overload (high overload HO).

³⁾ The input current depends on the motor load and line impedance. It applies with a line impedance of $u_k = 1\%$. The rated input currents apply for a load representing the rated power (based on I_{rated}) (these current values are specified on the rating plate).

SINAMICS G120

Inverter chassis units 0.37 kW to 90 kW

PM250 Power Modules

Technical specifications (continued)

Line voltage 380 ... 480 V 3 AC	PM250 Power Modules			
		6SL3225-0BE31-5AA0	6SL3225-0BE31-8AA0	6SL3225-0BE32-2AA0
With integrated line filter				
Rated output current $I_{rated}^{1)}$	A	38	45	60
Base load current $I_L^{1)}$	A	38	45	60
Base load current $I_H^{2)}$	A	32	38	45
Output current I_{max}	A	64	76	90
Rated power based on I_L	kW	18.5	22	30
Rated power based on I_H	kW	15	18.5	22
Rated pulse frequency	kHz	4	4	4
Efficiency η		0.95	0.95	0.95
Power loss	kW	available soon	available soon	available soon
Cooling air requirement	m ³ /s	0.022	0.022	0.039
Sound pressure level	dB(A)	available soon	available soon	available soon
24 V DC power supply for the Control Unit	A	1	1	1
Rated input current ³⁾	A	36	42	56
Input current based on $I_H^{3)}$	A	30	36	42
Line supply connection U1/L1, V1/L2, W1/L3		M6 screw studs	M6 screw studs	M6 screw studs
• Conductor cross-section	mm ²	10 ... 35	10 ... 35	10 ... 35
Motor connection U2, V2, W2		M6 screw studs	M6 screw studs	M6 screw studs
• Conductor cross-section	mm ²	10 ... 35	10 ... 35	10 ... 35
PE connection		On housing with M6 screw	On housing with M6 screw	On housing with M6 screw
Motor cable length, max.				
• Shielded	m	25	25	25
• Unshielded	m	100	100	100
Degree of protection		IP20	IP20	IP20
Dimensions				
• Width	mm	275	275	275
• Height	mm	512	512	512
• Depth				
- without Control Unit	mm	204	204	204
- with Control Unit	mm	260	260	260
Frame size		FSD	FSD	FSD
Weight, approx.	kg	15.4	15.4	16.0

¹⁾ The rated output current I_{rated} and the base load current I_L are based on the loading for light overload (light overload LO).

²⁾ The base load current I_H is based on the loading for high overload (high overload HO).

³⁾ The input current depends on the motor load and line impedance. It applies with a line impedance of $u_k = 1\%$. The rated input currents apply for a load representing the rated power (based on I_{rated}) (these current values are specified on the rating plate).

SINAMICS G120

Inverter chassis units 0.37 kW to 90 kW

PM250 Power Modules

Technical specifications (continued)

Line voltage 380 ... 480 V 3 AC		PM250 Power Modules				
		6SL3225- 0BE33-0AA0	6SL3225- 0BE33-7AA0	6SL3225- 0BE34-5AA0	6SL3225- 0BE35-5AA0	6SL3225- 0BE37-5AA0
With integrated line filter						
Rated output current $I_{rated}^{1)}$	A	75	90	110	145	178
Base load current $I_L^{1)}$	A	75	90	110	145	178
Base load current $I_H^{2)}$	A	60	75	90	110	145
Output current I_{max}	A	120	150	180	220	290
Rated power based on I_L	kW	37	45	55	75	90
Rated power based on I_H	kW	30	37	45	55	75
Rated pulse frequency	kHz	4	4	4	4	4
Efficiency η		0.95	0.95	0.95	0.95	0.95
Power loss	kW	available soon	available soon	available soon	available soon	available soon
Cooling air requirement	m ³ /s	0.022	0.039	0.094	0.094	0.117
Sound pressure level	dB(A)	available soon	available soon	available soon	available soon	available soon
24 V DC power supply for the Control Unit	A	1	1	1	1	1
Rated input current ³⁾	A	70	84	102	135	166
Input current based on $I_H^{3)}$	A	56	70	84	102	135
Line supply connection U1/L1, V1/L2, W1/L3		M6 screw studs	M6 screw studs	M8 screw studs	M8 screw studs	M8 screw studs
• Max. conductor cross-section	mm ²	10 ... 35	10 ... 35	1 × 120 or 2 × 50	1 × 120 or 2 × 50	1 × 120 or 2 × 50
Motor connection U2, V2, W2		M6 screw studs	M6 screw studs	M8 screw studs	M8 screw studs	M8 screw studs
• Max. conductor cross-section	mm ²	10 ... 35	10 ... 35	1 × 120 or 2 × 50	1 × 120 or 2 × 50	1 × 120 or 2 × 50
PE connection		On housing with M6 screw	On housing with M6 screw	On housing with M8 screw	On housing with M8 screw	On housing with M8 screw
Motor cable length, max.						
• Shielded	m	25	25	25	25	25
• Unshielded	m	100	100	100	100	100
Degree of protection		IP20	IP20	IP20	IP20	IP20
Dimensions						
• Width	mm	275	275	350	350	350
• Height	mm	635	635	934	934	934
• Depth						
- without Control Unit	mm	204	204	316	316	316
- with Control Unit	mm	260	260	372	372	372
Frame size		FSE	FSE	FSF	FSF	FSF
Weight, approx.	kg	21.0	21.0	51.0	51.0	51.0

¹⁾ The rated output current I_{rated} and the base load current I_L are based on the loading for light overload (light overload LO).

²⁾ The base load current I_H is based on the loading for high overload (high overload HO).

³⁾ The input current depends on the motor load and line impedance. It applies with a line impedance of $u_k = 1\%$. The rated input currents apply for a load representing the rated power (based on I_{rated}) (these current values are specified on the rating plate).

SINAMICS G120

Inverter chassis units 0.37 kW to 90 kW

PM250 Power Modules

Selection and ordering data

Rated output ¹⁾		Rated output current ²⁾	Power based on the base load current ³⁾		Base load current ³⁾	Frame size	SINAMICS G120 Power Module PM250 with integrated line filter class A Order No.
kW	hp	I_{rated} A	kW	hp	I_H A		
380 ... 480 V 3 AC							
7.5	10	18	5.5	7.5	13.2	FSC	6SL3225-0BE25-5AA0
11.0	15	25	7.5	10	19	FSC	6SL3225-0BE27-5AA0
15.0	20	32	11.0	15	26	FSC	6SL3225-0BE31-1AA0
18.5	25	38	15.0	20	32	FSD	6SL3225-0BE31-5AA0
22	30	45	18.5	25	38	FSD	6SL3225-0BE31-8AA0
30	40	60	22	30	45	FSD	6SL3225-0BE32-2AA0
37	50	75	30	40	60	FSE	6SL3225-0BE33-0AA0
45	60	90	37	50	75	FSE	6SL3225-0BE33-7AA0
55	75	110	45	60	90	FSF	6SL3225-0BE34-5AA0
75	100	145	55	75	110	FSF	6SL3225-0BE35-5AA0
90	125	178	75	100	145	FSF	6SL3225-0BE37-5AA0

¹⁾ Rated output based on the rated output current I_{rated} . The rated output current I_{rated} is based on the loading for light overload (light overload LO).

²⁾ The rated output current I_{rated} is based on the loading for light overload (light overload LO). These current values are quoted on the rating plate of the Power Module.

³⁾ The base load current I_H is based on the loading for high overload (high overload HO).

SINAMICS G120

Inverter chassis units 0.37 kW to 90 kW

PM250 Power Modules

Characteristic curves

Derating data

Pulse frequency

Rated output at 400 V 3 AC		Rated output current in A at a switching frequency of						
kW	hp	4 kHz	6 kHz	8 kHz	10 kHz	12 kHz	14 kHz	16 kHz
7.5	10	18	12.5	11.9	10.6	9.2	7.9	6.6
11.0	15	25	18.1	17.1	15.2	13.3	11.4	9.5
15.0	20	32	24.7	23.4	20.8	18.2	15.6	13
18.5	25	38	32	27	23	19	17	15
22.0	30	45	38	32	27	23	20	18
30.0	40	60	51	42	36	30	27	24
37.0	50	75	64	53	45	38	34	30
45.0	60	90	77	63	54	45	41	36
55.0	75	110	94	77	–	–	–	–
75.0	100	145	123	102	–	–	–	–
90.0	125	178	151	125	–	–	–	–

Ambient temperature

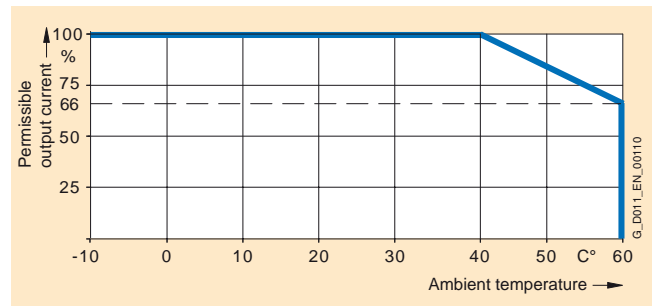
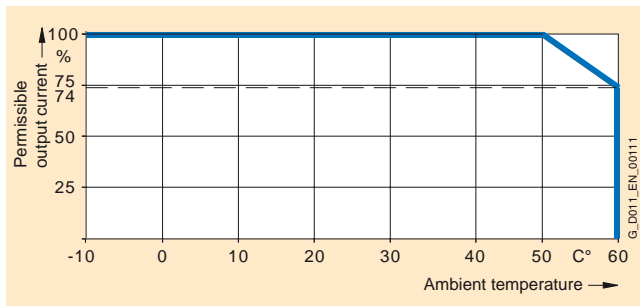

High overload (HO)

Light overload (LO)

Installation altitude

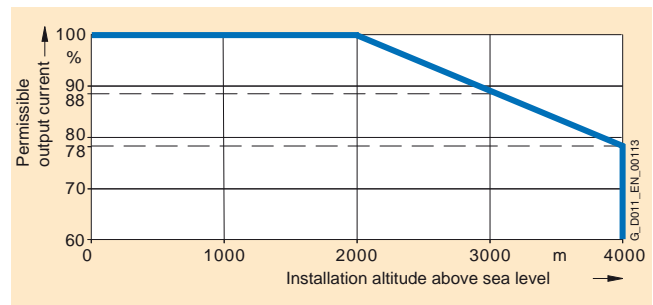
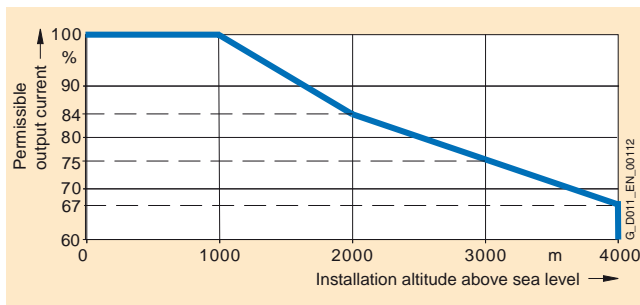

SINAMICS G120

Inverter chassis units 0.37 kW to 90 kW

PM250 Power Modules

Dimensional drawings

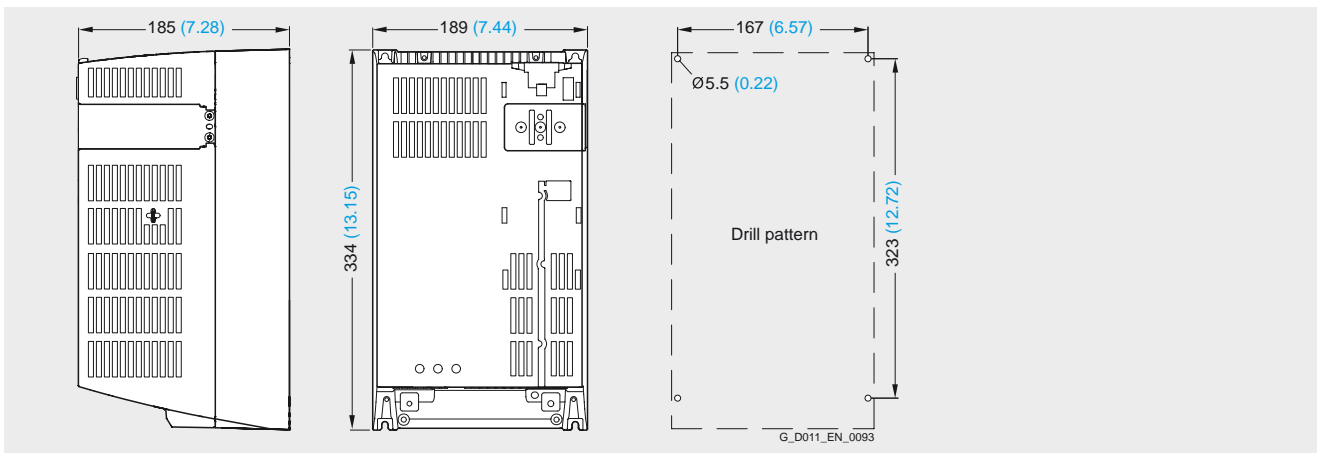

Power Module PM250 frame size FSC with integrated line filter class A

Fixing with 4 M5 studs, 4 M5 nuts, 4 M5 washers

Tightening torque: 2.5 Nm (22.1 lbf-in)

Ventilation clearance required at top and bottom:
125 mm (4.92 inches)

Ventilation clearance required at sides: 50 mm (1.97 inches)

When the Control Unit is plugged in, the mounting depth increases by 65 mm (2.56 inches).

All dimensions in mm (values in brackets are in inches).

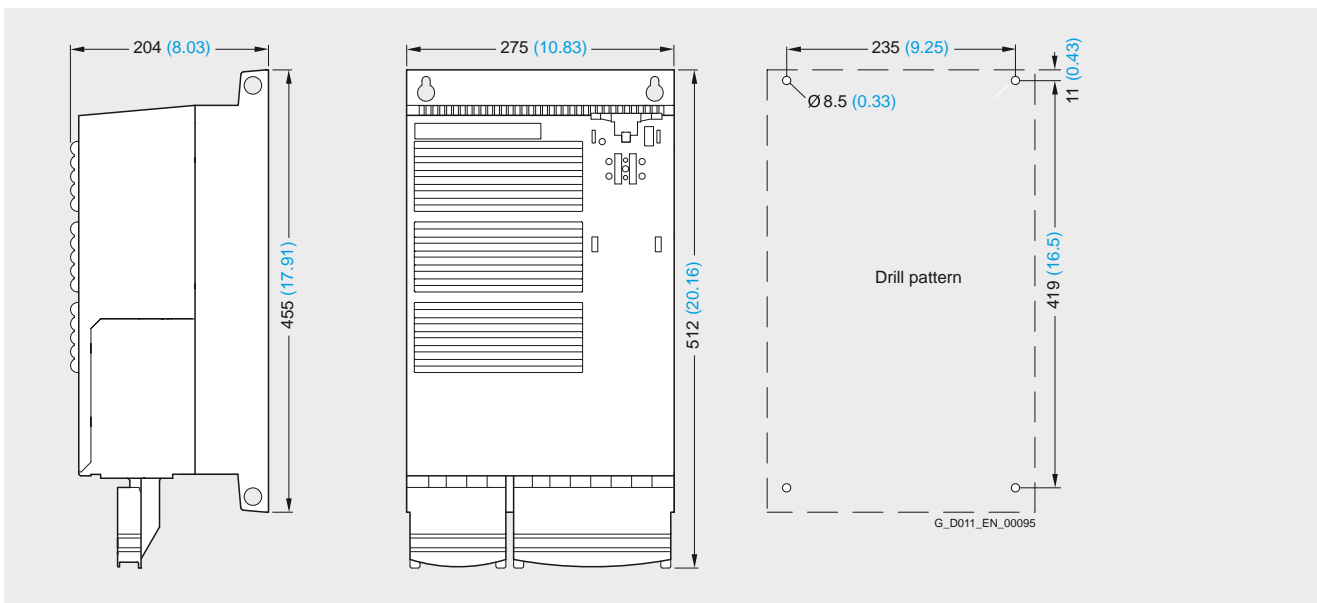

Power Module PM250 frame size FSD with integrated line filter class A

Fixing with 4 M6 studs, 4 M6 nuts, 4 M6 washers

Tightening torque: 6 Nm (53 lbf-in)

Ventilation clearance required at top and bottom:
300 mm (11.81 inches)

When the Control Unit is plugged in, the mounting depth increases by 56 mm (2.2 inches).

All dimensions in mm (values in brackets are in inches).

SINAMICS G120

Inverter chassis units 0.37 kW to 90 kW

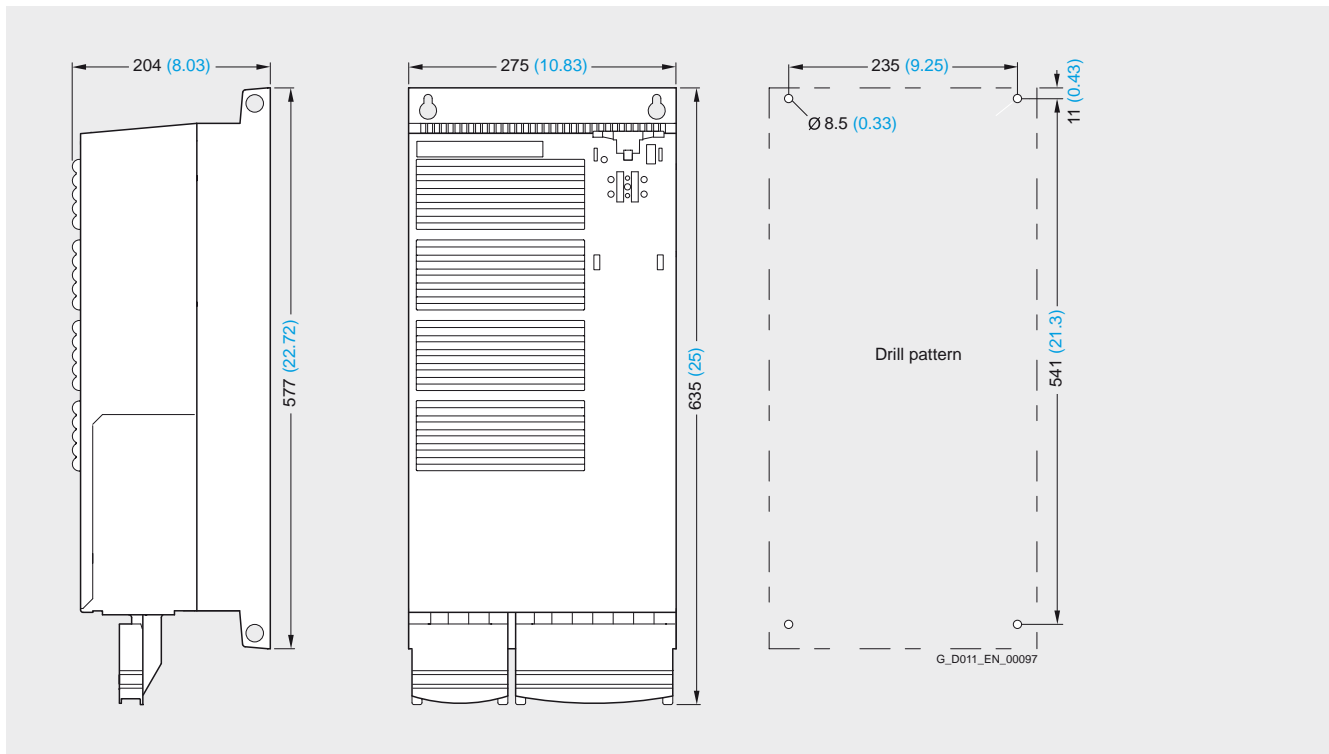
PM250 Power Modules
Dimensional drawings (continued)

Power Module PM250 frame size FSE with integrated line filter class A

Fixing with 4 M6 studs, 4 M6 nuts, 4 M6 washers

Tightening torque: 6 Nm (53 lbf-in)

Ventilation clearance required at top and bottom:
300 mm (11.81 inches)

When the Control Unit is plugged in, the mounting depth increases by 56 mm (2.2 inches).

All dimensions in mm (values in brackets are in inches).

SINAMICS G120

Inverter chassis units 0.37 kW to 90 kW

PM250 Power Modules

Dimensional drawings (continued)

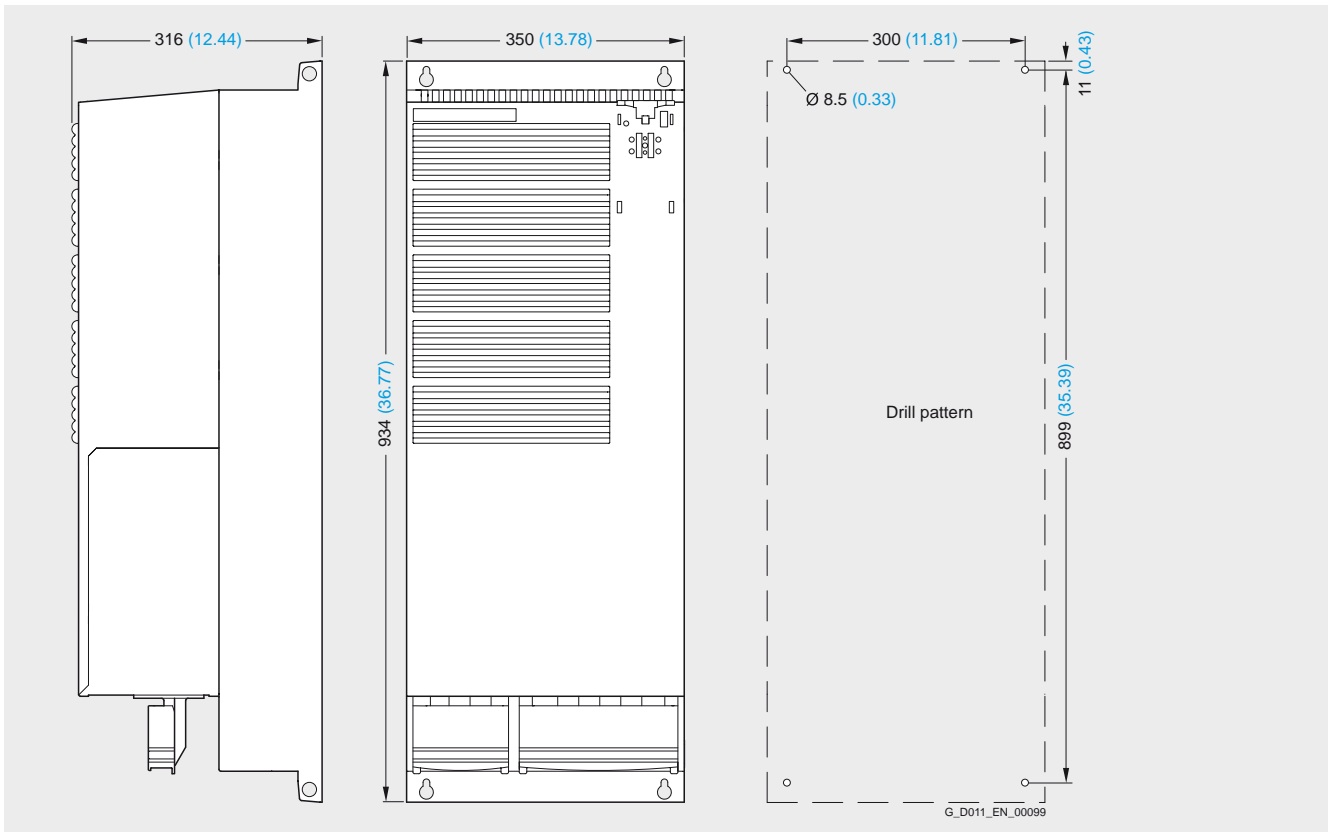

Power Module PM250 frame size FSF with integrated line filter class A

Fixing with 4 M8 studs, 4 M8 nuts, 4 M8 washers

Tightening torque: 13 Nm (115 lbf-in)

Ventilation clearance required at top and bottom:
350 mm (13.78 inches)

When the Control Unit is plugged in, the mounting depth increases by 56 mm (2.2 inches).

All dimensions in mm (values in brackets are in inches).

SINAMICS G120

Inverter chassis units 0.37 kW to 90 kW

PM260 Power Modules

Overview



Example of Power Module PM260 FSD

The regenerative feedback capability of the PM260 Power Module in generating mode (electronic braking) means that energy is returned to the supply system and not destroyed in a braking resistor. This saves space in the control cabinet, time-consuming dimensioning of the braking resistor as well as the wiring. Generated heat is also reduced in the control cabinet.

An innovative circuit design reduces supply harmonics. There is no need to use an optional line reactor at the supply infeed. This saves space and costs for engineering and procurement.

The PM260 Power Modules are also characterized by a high standard pulse frequency and an integrated sine-wave filter. The integral sine-wave filter ensures that the inverter output current is sinusoidal and supports cable lengths of up to 200 m shielded and 300 m unshielded. An output reactor is therefore not required. Furthermore, lower bearing currents are generated which reduces stress on the motor.

Standard motors can be used in combination with Power Modules PM260. An increased dielectric strength of the winding system is not required.

The PM260 Power Module is suitable for safety-sensitive applications. In conjunction with a Safety Control Unit, the drive can be turned into a Safety Integrated Drive (see Control Units).

The PM260 Power Modules with integrated line filter to class A are suitable only for connection to TN supply systems. Power Modules without integrated line filter can be connected to grounded (TN, TT) and non-grounded (IT) supply systems.

SINAMICS G120

Inverter chassis units 0.37 kW to 90 kW

PM260 Power Modules

Integration

PM260 Power Modules communicate with the Control Unit via the PM-IF interface.

PM260 Power Modules feature the following interfaces as standard:

- PM-IF interface for connection of the PM260 Power Module and Control Unit. The PM260 Power Module also supplies power to the Control Unit by means of an integrated power pack

- Motor connection made with screw terminals or screw studs
- Drive circuit for the Brake Relay or the Safe Brake Relay for controlling a holding brake
- 2 x PE (protective earth) connections

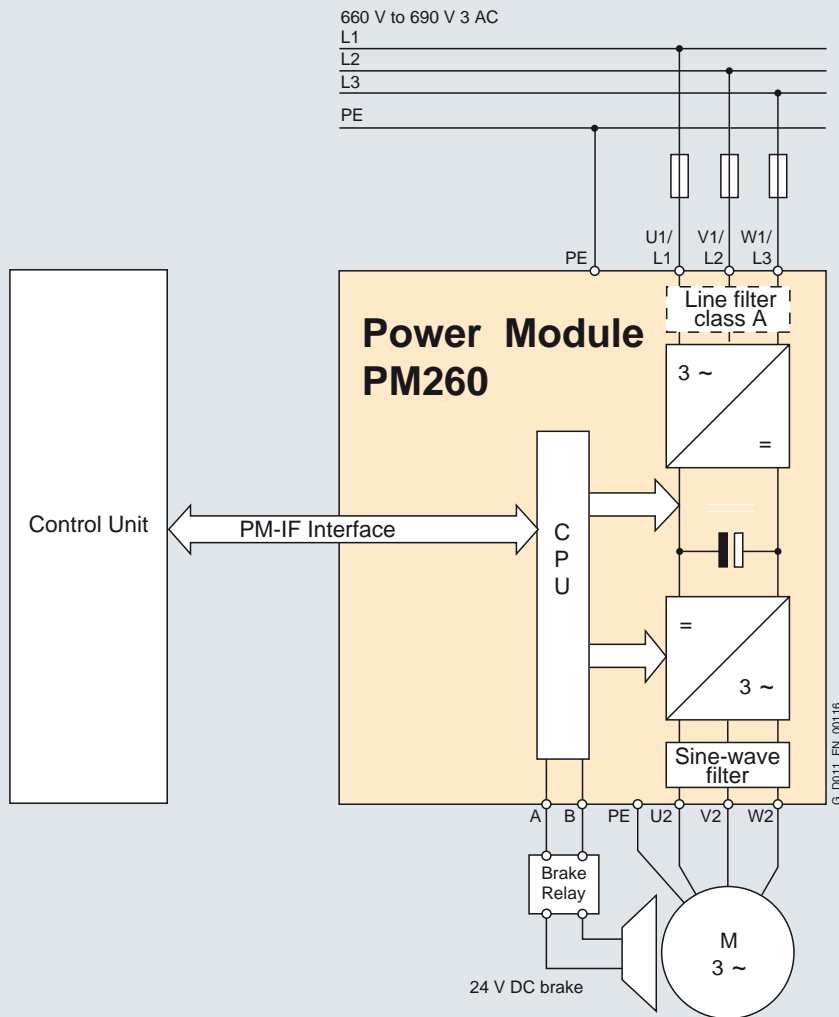

Connection diagram for PM260 Power Module with or without integrated line filter class A

SINAMICS G120

Inverter chassis units 0.37 kW to 90 kW

PM260 Power Modules

Technical specifications

General technical data

PM260 Power Modules	
Line operating voltage	660 ... 690 V 3 AC $\pm 10\%$ The power units can also be operated with a minimal voltage of 500 V. In this case, the power is reduced linearly – see derating characteristics.
Line requirements Line short circuit voltage u_k	$\leq 1\%$
Input frequency	47 ... 63 Hz
Output frequency	
• Control type V/f	0 ... 200 Hz
• Control type Vector	0 ... 200 Hz
Pulse frequency	16 kHz (standard)
Power factor	0.95
Inverter efficiency	95 ... 97%
Control factor	87%
Overload capability	
• High overload (HO)	1.5 x rated output current (i.e. 150% overload) for 57 s with a cycle time of 300 s 2 x rated output current (i.e. 200% overload) for 3 s with a cycle time of 300 s
• Light overload (LO)	1.1 x rated output current (i.e. 110% overload) for 57 s with a cycle time of 300 s 1.4 x rated output current (i.e. 140% overload) for 3 s with a cycle time of 300 s
Electromagnetic compatibility	Optional line filter class A or B compliant with EN 55011 available
Possible braking methods	Regenerative feedback in generating mode
Degree of protection	IP20
Operating temperature	
• High overload (HO)	-10 ... +50 °C (14 ... 122 °F) without derating, > 50 ... 60 °C, see derating characteristics
• Light overload (LO)	-10 ... +40 °C (14 ... 104 °F) without derating, > 40 ... 60 °C, see derating characteristics
Storage temperature	-40 ... +70 °C (-40 ... +158 °F)
Relative humidity	< 95% RH, non-condensing
Cooling	Internal ventilator, power units with increased air cooling by built-in fans
Installation altitude	Up to 1000 m above sea level without derating, > 1000 m see derating characteristics
Standard SCCR (Short Circuit Current Rating) ¹⁾	42 kA
Protective functions	<ul style="list-style-type: none"> • Undervoltage • Overvoltage • Overload • Ground fault • Short-circuit • Stall prevention • Motor blocking protection • Motor overtemperature • Inverter overtemperature • Parameter interlock
Standards conformance	CE
CE mark	To Low-Voltage Directive 73/23/EEC and Machinery Directive 98/37/EEC

¹⁾ Applies to industrial control cabinet installations to NEC article 409/UL 508A. For further information, visit us on the Internet at:
<http://support.automation.siemens.com/WW/view/en/23995621>

SINAMICS G120

Inverter chassis units 0.37 kW to 90 kW

PM260 Power Modules

Technical specifications (continued)

Line voltage 660 ... 690 V 3 AC		PM260 Power Modules			
			6SL3225-0BH27-5UA0 6SL3225-0BH27-5AA0	6SL3225-0BH31-1UA0 6SL3225-0BH31-1AA0	6SL3225-0BH31-5UA0 6SL3225-0BH31-5AA0
Without integrated line filter					
With integrated line filter					
Rated output current $I_{rated}^{1)}$	A	14	19	23	
Base load current $I_L^{1)}$	A	14	19	23	
Base load current $I_H^{2)}$	A	10	14	19	
Output current I_{max}	A	20	28	38	
Rated power based on I_L	kW	11	15	18.5	
Rated power based on I_H	kW	7.5	11	15	
Rated pulse frequency	kHz	16	16	16	
Efficiency η		0.95	0.95	0.95	
Power loss with LO/HO	kW	0.56/0.38	0.70/0.56	0.87/0.70	
Cooling air requirement	m ³ /s	0.022	0.022	0.039	
Sound pressure level	dB(A)	< 64	< 64	< 64	
24 V DC power supply for the Control Unit	A	1	1	1	
Rated input current ³⁾	A	13	18	22	
Input current based on $I_H^{3)}$	A	10	13	18	
Line supply connection U1/L1, V1/L2, W1/L3		Plug strip	Plug strip	Plug strip	
• Conductor cross-section	mm ²	2.5 ... 16	2.5 ... 16	2.5 ... 16	
Motor connection U2, V2, W2		Terminal block	Terminal block	Terminal block	
• Conductor cross-section	mm ²	2.5 ... 16	2.5 ... 16	2.5 ... 16	
PE connection		On housing with M6 screw	On housing with M6 screw	On housing with M6 screw	
Motor cable length, max.					
• Shielded	m	200	200	200	
• Unshielded	m	300	300	300	
Degree of protection		IP20	IP20	IP20	
Dimensions					
• Width	mm	275	275	275	
• Height	mm	512	512	512	
• Depth					
- without Control Unit	mm	204	204	204	
- with Control Unit	mm	260	260	260	
Frame size		FSD	FSD	FSD	
Weight, approx.					
• without integrated filter	kg	20	20	20	
• with integrated filter	kg	21	21	21	

¹⁾ The rated output current I_{rated} and the base load current I_L are based on the loading for light overload (light overload LO).

²⁾ The base load current I_H is based on the loading for high overload (high overload HO).

³⁾ The input current depends on the motor load and line impedance. It applies with a line impedance of $u_k = 1\%$. The rated input currents apply for a load representing the rated power (based on I_{rated}) (these current values are specified on the rating plate).

SINAMICS G120

Inverter chassis units 0.37 kW to 90 kW

PM260 Power Modules

Technical specifications (continued)

Line voltage 660 ... 690 V 3 AC		PM260 Power Modules			
		6SL3225-0BH32-2UA0 6SL3225-0BH32-2AA0	6SL3225-0BH33-0UA0 6SL3225-0BH33-0AA0	6SL3225-0BH33-7UA0 6SL3225-0BH33-7AA0	
Without integrated line filter					
With integrated line filter					
Rated output current $I_{rated}^{1)}$	A	35	42	62	
Base load current $I_L^{1)}$	A	35	42	62	
Base load current $I_H^{2)}$	A	26	35	42	
Output current I_{max}	A	52	70	84	
Rated power based on I_L	kW	30	37	55	
Rated power based on I_H	kW	22	30	37	
Rated pulse frequency	kHz	16	16	16	
Efficiency η		0.95	0.95	0.95	
Power loss with LO/HO	kW	0.86/0.56	1.06/0.86	1.62/1.06	
Cooling air requirement	m ³ /s	0.094	0.094	0.117	
Sound pressure level	dB(A)	< 70	< 70	< 70	
24 V DC power supply for the Control Unit	A	1	1	1	
Rated input current ³⁾	A	34	41	60	
Input current based on $I_H^{3)}$	A	26	34	41	
Line supply connection U1/L1, V1/L2, W1/L3		M6 screw studs	M6 screw studs	M6 screw studs	
• Conductor cross-section	mm ²	10 ... 35	10 ... 35	10 ... 35	
Motor connection U2, V2, W2		M6 screw studs	M6 screw studs	M6 screw studs	
• Conductor cross-section	mm ²	10 ... 35	10 ... 35	10 ... 35	
PE connection		On housing with M6 screw	On housing with M6 screw	On housing with M6 screw	
Motor cable length, max.					
• Shielded	m	200	200	200	
• Unshielded	m	300	300	300	
Type of protection		IP20	IP20	IP20	
Dimensions					
• Width	mm	350	350	350	
• Height	mm	634	634	634	
• Depth					
- without Control Unit	mm	316	316	316	
- with Control Unit	mm	372	372	372	
Frame size		FSF	FSF	FSF	
Weight, approx.					
• without integrated filter	kg	46	46	46	
• with integrated filter	kg	48	48	48	

¹⁾ The rated output current I_{rated} and the base load current I_L are based on the loading for light overload (light overload LO).

²⁾ The base load current I_H is based on the loading for high overload (high overload HO).

³⁾ The input current depends on the motor load and line impedance. It applies with a line impedance of $u_k = 1\%$. The rated input currents apply for a load representing the rated power (based on I_{rated}) (these current values are specified on the rating plate).

SINAMICS G120

Inverter chassis units 0.37 kW to 90 kW

PM260 Power Modules

Selection and ordering data

Rated output ¹⁾		Rated output current ²⁾		Power based on the base load current ³⁾		Base load current ³⁾	Frame size	SINAMICS G120 Power Module PM260 without integrated line filter	SINAMICS G120 Power Module PM260 with integrated line filter class A
kW	hp	A	I_{rated}	kW	hp	A		Order No.	Order No.
660 ... 690 V 3 AC									
11.0	15	14		7.5	10	10	FSD	6SL3224-0BH27-5UA0	6SL3224-0BH27-5AA0
15.0	20	19		11	15	14	FSD	6SL3224-0BH31-1UA0	6SL3224-0BH31-1AA0
18.5	25	23		15	20	19	FSD	6SL3224-0BH31-5UA0	6SL3224-0BH31-5AA0
30	40	35		22	30	26	FSF	6SL3224-0BH32-2UA0	6SL3224-0BH32-2AA0
37	50	42		30	40	35	FSF	6SL3224-0BH33-0UA0	6SL3224-0BH33-0AA0
55	75	62		37	50	42	FSF	6SL3224-0BH33-7UA0	6SL3224-0BH33-7AA0

Characteristic curves

Derating data

Ambient temperature

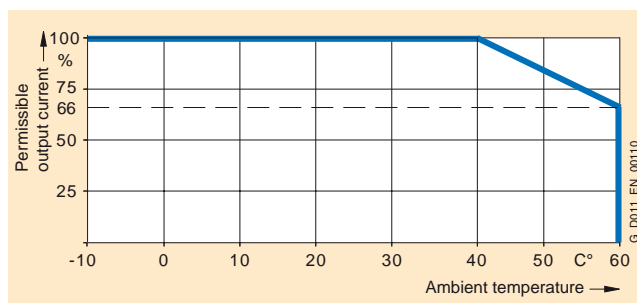
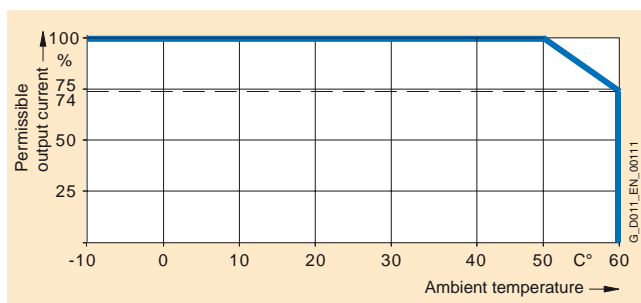

High overload (HO)

Light overload (LO)

Installation altitude

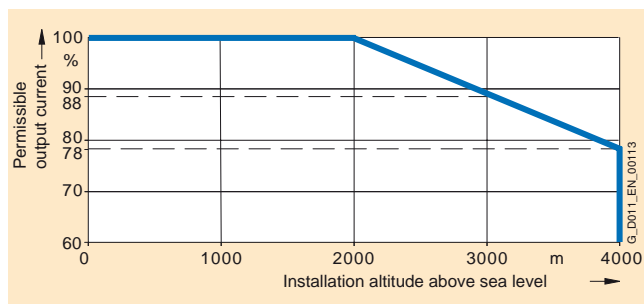
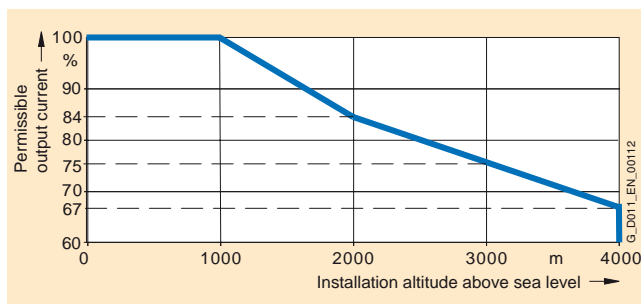

Line operating voltage

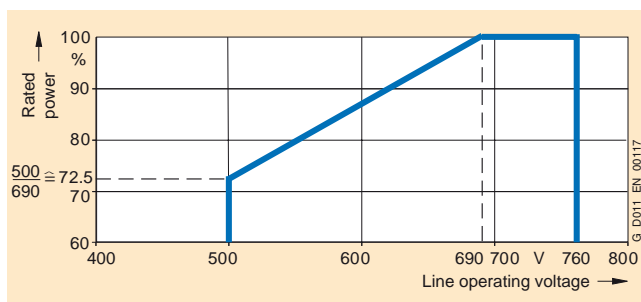

The power units can also be operated with a minimum voltage of 500 V. In this case, the power is reduced linearly.

¹⁾ Rated output based on the rated output current I_{rated} . The rated output current I_{rated} is based on the loading for light overload (light overload LO).

²⁾ The rated output current I_{rated} is based on the loading for light overload (light overload LO). These current values are quoted on the rating plate of the Power Module.

³⁾ The base load current I_H is based on the loading for high overload (high overload HO).

SINAMICS G120

Inverter chassis units 0.37 kW to 90 kW

PM260 Power Modules

Dimensional drawings

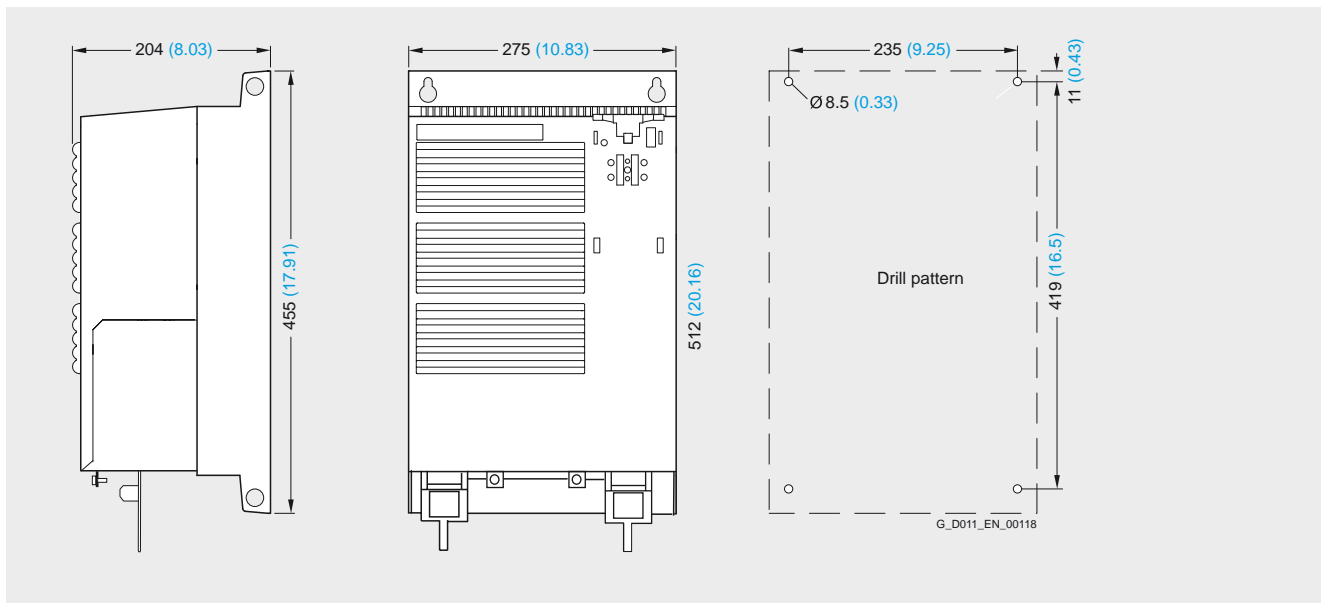

Power Module PM260 frame size FSD with and without integrated line filter class A

Fixing with 4 M6 studs, 4 M6 nuts, 4 M6 washers

Tightening torque: 6 Nm (53 lbf-in)

Ventilation clearance required at top and bottom: 300 mm (11.81 inches)

When the Control Unit is plugged in, the mounting depth increases by 56 mm (2.2 inches).

All dimensions in mm (values in brackets are in inches).

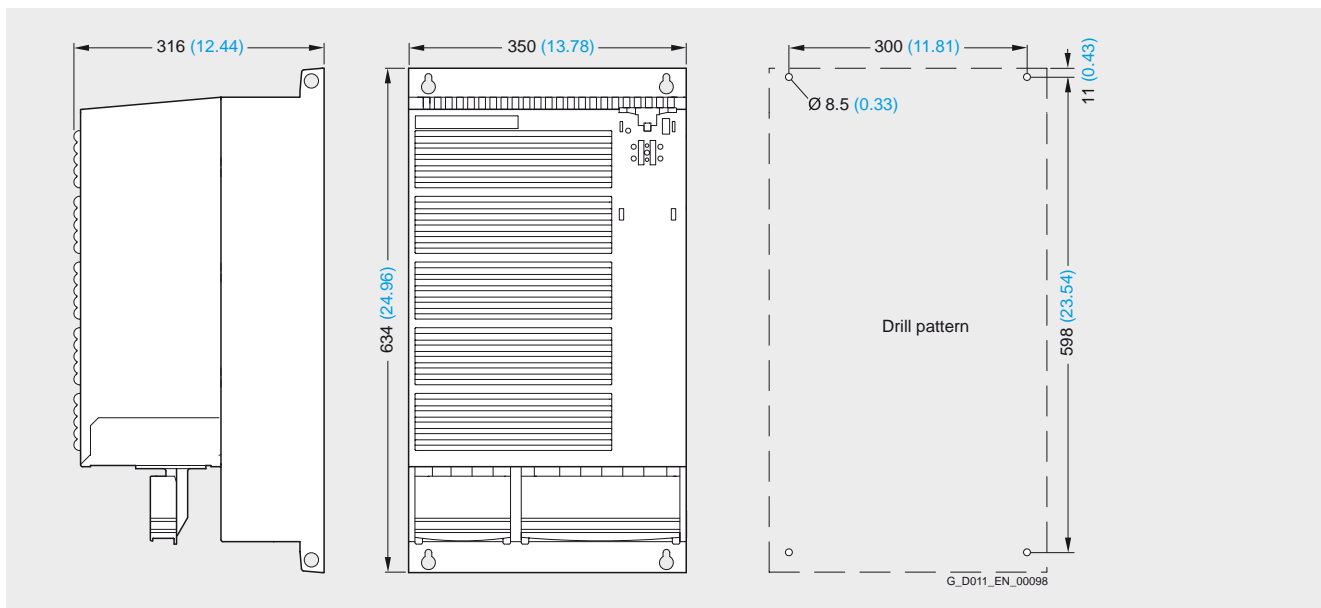

Power Module PM260 frame size FSF with and without integrated line filter class A

Fixing with 4 M8 studs, 4 M8 nuts, 4 M8 washers

Tightening torque: 13 Nm (115 lbf-in)

Ventilation clearance required at top and bottom: 350 mm (13.78 inches)

When the Control Unit is plugged in, the mounting depth increases by 56 mm (2.2 inches).

All dimensions in mm (values in brackets are in inches).

SINAMICS G120

Inverter chassis units 0.37 kW to 90 kW

Line-side power components

Line filters

Overview



Example: Line filter for Power Modules frame size FSA

The Power Module complies with a higher radio interference class when an additional line filter is used.

Frame size FSA of the PM240 Power Module is available only without integrated line filter to class A. A base filter for compliance with class A and another for compliance with class B are therefore available.

Frame sizes FSB and FSC of the PM240 Power Module are available both with and without integrated line filter to class A. For compliance with class B, PM240 Power Modules with integrated line filter to class A must be fitted additionally with a base filter to class B.

Frame sizes FSC of the PM250 Power Module are available only with integrated line filter to class A. For compliance with class B, PM250 Power Modules with integrated line filter to class A must be fitted additionally with a base filter to class B.

No additional class B line filters are available for the PM260 Power Module.

Technical specifications

Line voltage 380 ... 480 V 3 AC	Line filter class A		Line filter class B		
		6SE6400-2FA00-6AD0	6SE6400-2FB00-6AD0	6SL3203-0BE21-6SA0	6SL3203-0BD23-8SA0
Rated current	A	6	6	10.2	39.4
Line supply connection L1, L2, L3		Screw terminals	Screw terminals	Screw terminals	Screw terminals
• Conductor cross-section	mm ²	2.5	2.5	2.5	4
Load connection U, V, W		Shielded cable	Shielded cable	Shielded cable	Shielded cable
• Conductor cross-section	mm ²	3 × 2.5	3 × 2.5	3 × 2.5	3 × 4
• Length	m	0.4	0.4	0.4	0.4
PE connection		On housing with M4 screw studs	On housing with M4 screw studs	On housing with M4 screw studs	On housing with M4 screw studs
Degree of protection		IP20	IP20	IP20	IP20
Dimensions					
• Width	mm	73	73	153	190
• Height	mm	200	200	296	362
• Depth	mm	42.5	42.5	50	55
Possible as base component		Yes	Yes	Yes	Yes
Weight, approx.	kg	0.5	0.5	1.5	2.3
Suitable for PM240 Power Module	Type	6SL3224-0BE13-7UA0 6SL3224-0BE15-5UA0 6SL3224-0BE17-5UA0 6SL3224-0BE21-1UA0 6SL3224-0BE21-5UA0	6SL3224-0BE13-7UA0 6SL3224-0BE15-5UA0 6SL3224-0BE17-5UA0 6SL3224-0BE21-1UA0 6SL3224-0BE21-5UA0	6SL3224-0BE22-2AA0 6SL3224-0BE23-0AA0 6SL3224-0BE24-0AA0	6SL3224-0BE25-5AA0 6SL3224-0BE27-5AA0 6SL3224-0BE31-1AA0
Suitable for PM250 Power Module					6SL3225-0BE25-5AA0 6SL3225-0BE27-5AA0 6SL3225-0BE31-1AA0
Frame size		FSA	FSA	FSB	FSC

SINAMICS G120

Inverter chassis units 0.37 kW to 90 kW

Line-side power components
Line filters

Selection and ordering data

Rated output		SINAMICS G120 Power Module <u>PM240</u>		Line filter to class A
kW	hp	Type 6SL3224-...	Frame size	according to EN 55011
Order No.				
380 ... 480 V 3 AC				
0.37	0.50	0BE13-7UA0	FSA	6SE6400-2FA00-6AD0
0.55	0.75	0BE15-5UA0	FSA	
0.75	1.0	0BE17-5UA0	FSA	
1.1	1.5	0BE21-1UA0	FSA	
1.5	2.0	0BE21-5UA0	FSA	
Rated output		SINAMICS G120 Power Module <u>PM240</u>		Line filter to class B
kW	hp	Type 6SL3224-...	Frame size	according to EN 55011
Order No.				
380 ... 480 V 3 AC				
0.37	0.50	0BE13-7UA0	FSA	6SE6400-2FB00-6AD0
0.55	0.75	0BE15-5UA0	FSA	
0.75	1.0	0BE17-5UA0	FSA	
1.1	1.5	0BE21-1UA0	FSA	
1.5	2	0BE21-5UA0	FSA	
2.2	3	0BE22-2AA0	FSB	6SL3203-0BE21-6SA0
3.0	4	0BE23-0AA0	FSB	
4.0	5	0BE24-0AA0	FSB	
7.5	10	0BE25-5AA0	FSC	6SL3203-0BD23-8SA0
11	15	0BE27-5AA0	FSC	
15	20	0BE31-1AA0	FSC	
Rated output		SINAMICS G120 Power Module <u>PM250</u>		Line filter to class B
kW	hp	Type 6SL3225-...	Frame size	according to EN 55011
Order No.				
380 ... 480 V 3 AC				
7.5	10	0BE25-5AA0	FSC	6SL3203-0BD23-8SA0
11	15	0BE27-5AA0	FSC	
15	20	0BE31-1AA0	FSC	

SINAMICS G120

Inverter chassis units 0.37 kW to 90 kW

Line-side power components

Line reactors

Overview



Example: Line reactors for Power Modules frame sizes FSA to FSE



Example: Power Module frame size FSB with base line reactor and shield connection plate

A line reactor is needed for high system fault levels, partly to protect the actual inverter against excessive harmonic currents, and thus against overload, and partly to limit the system perturbation to the permitted values.

Note: A line reactor must not be used in combination with a PM250 or PM260 Power Module.

Integration

The line reactors for PM240 Power Modules of frame sizes FSA to FSE are designed as base components. The line reactor is attached to the mounting surface and the Power Module is mounted compactly on the line reactor. The cables to the Power Modules are already connected to the line reactor.

The line reactor is connected to the line supply through terminals.

SINAMICS G120

Inverter chassis units 0.37 kW to 90 kW

Line-side power components Line reactors

Technical specifications

Line voltage 380 ... 480 V 3 AC		Line reactor			
		6SE6400-3CC00-2AD3	6SE6400-3CC00-4AD3	6SE6400-3CC00-6AD3	6SL3203-0CD21-0AA0
Rated current	A	1.9	3.5	4.8	9
Power loss at 50/60 Hz, approx.	W	6/7	12.5/15	7.5/9	9/11
Line connection U1, V1, W1		Screw terminals	Screw terminals	Screw terminals	Screw terminals
• Conductor cross-section	mm ²	6	6	6	6
Load connection		Cable	Cable	Cable	Cable
• Conductor cross-section		4 × AWG16 (1.5 mm ²)	4 × AWG16 (1.5 mm ²)	4 × AWG16 (1.5 mm ²)	4 × AWG16 (1.5 mm ²)
• Length, approx.	m	0.38	0.38	0.38	0.46
PE connection		On housing with M5 screw stud	On housing with M5 screw stud	On housing with M5 screw stud	On housing with M5 screw stud
Degree of protection		IP20	IP20	IP20	IP20
Dimensions					
• Width	mm	75.5	75.5	75.5	153
• Height	mm	200	200	200	290
• Depth	mm	50	50	50	70
Possible as base component		Yes	Yes	Yes	Yes
Weight, approx.	kg	0.6	0.8	0.6	3.4
Suitable for PM240 Power Module	Type	6SL3224-0BE13-7UA0 6SL3224-0BE15-5UA0	6SL3224-0BE17-5UA0 6SL3224-0BE21-1UA0	6SL3224-0BE21-5UA0	6SL3224-0BE22-2 . A0 6SL3224-0BE23-0 . A0
Frame size		FSA	FSA	FSA	FSB

Line voltage 380 ... 480 V 3 AC		Line reactor			
		6SL3203-0CD21-4AA0	6SL3203-0CD22-2AA0	6SL3203-0CD23-5AA0	6SL3203-0CJ24-5AA0
Rated current	A	11.6	25	31.3	45.8
Power loss at 50/60 Hz, approx.	W	27/32	98/118	37/44	90/115
Line connection U1, V1, W1		Screw terminals	Screw terminals	Screw terminals	Screw terminals
• Conductor cross-section	mm ²	6	6	16	16
Load connection		Cable	Cable	Cable	Cable
• Conductor cross-section		4 × AWG16 (1.5 mm ²)	4 × AWG10 (2.5 mm ²)	4 × AWG10 (2.5 mm ²)	4 × 16 mm ²
• Length, approx.	m	0.46	0.49	0.49	0.7
PE connection		On housing with M5 screw stud	On housing with M5 screw stud	On housing with M5 screw stud	On housing with M8 screw stud
Degree of protection		IP20	IP20	IP20	IP20
Dimensions					
• Width	mm	153	189	189	275
• Height	mm	290	371	371	455
• Depth	mm	70	50	50	84
Possible as base component		Yes	Yes	Yes	Yes
Weight, approx.	kg	3.4	5.2	5.9	13
Suitable for PM240 Power Module	Type	6SL3224-0BE24-0 . A0	6SL3224-0BE25-5 . A0 6SL3224-0BE27-5 . A0	6SL3224-0BE31-1 . A0	6SL3224-0BE31-5 . A0 6SL3224-0BE31-8 . A0
Frame size		FSB	FSC	FSC	FSD

SINAMICS G120

Inverter chassis units 0.37 kW to 90 kW

Line-side power components Line reactors

Technical specifications (continued)

Line voltage 380 ... 480 V 3 AC	Line reactor				
		6SL3203-0CD25-3AA0	6SL3203-0CJ28-6AA0	6SE6400-3CC11-2FD0	6SE6400-3CC11-7FD0
Rated current	A	53.6	86.9	129	183
Power loss at 50/60 Hz, approx.	W	90/115	170/215	280/360	280/360
Line connection U1, V1, W1		Screw terminals	Screw terminals	Flat connector for M10 cable lug	Flat connector for M10 cable lug
• Conductor cross-section	mm ²	16	50	–	–
Load connection		Cable	Cable	Flat connector for M10 cable lug	Flat connector for M10 cable lug
• Conductor cross-section	mm ²	4 × 16	4 × 35	–	–
• Length, approx.	m	0.7	0.7	–	–
PE connection		On housing with M8 screw	On housing with M8 screw	On housing with M8 screw stud	On housing with M8 screw stud
Degree of protection		IP20	IP20	IP00	IP00
Dimensions					
• Width	mm	275	275	240	240
• Height	mm	455	577	228	228
• Depth	mm	84	94	141	141
Possible as base component		Yes	Yes	no	no
Weight, approx.	kg	13	19	25	25
Suitable for PM240 Power Module	Type	6SL3224-0BE32-2 . A0	6SL3224-0BE33-0 . A0 6SL3224-0BE33-7 . A0	6SL3224-0BE34-5 . A0 6SL3224-0BE35-5 . A0	6SL3224-0BE37-5 . A0
Frame size		FSD	FSE	FSF	FSF

Selection and ordering data

Rated output		SINAMICS G120 Power Module PM240		Line reactor
kW	hp	Type 6SL3224-...	Frame size	Order No.
380 ... 480 V 3 AC				
0.37	0.50	0BE13-7UA0	FSA	6SE6400-3CC00-2AD3
0.55	0.75	0BE15-5UA0	FSA	
0.75	1.0	0BE17-5UA0	FSA	
1.1	1.5	0BE21-1UA0	FSA	6SE6400-3CC00-4AD3
1.5	2	0BE21-5UA0	FSA	
2.2	3	0BE22-2 . A0	FSB	6SL3203-0CD21-0AA0
3.0	4	0BE23-0 . A0	FSB	
4.0	5	0BE24-0 . A0	FSB	6SL3203-0CD21-4AA0
7.5	10	0BE25-5 . A0	FSC	
11.0	15	0BE27-5 . A0	FSC	6SL3203-0CD22-2AA0
15.0	20	0BE31-1 . A0	FSC	
18.5	25	0BE31-5 . A0	FSD	6SL3203-0CJ24-5AA0
22	30	0BE31-8 . A0	FSD	
30	40	0BE32-2 . A0	FSD	6SL3203-0CD25-3AA0
37	50	0BE33-0 . A0	FSE	
45	60	0BE33-7 . A0	FSE	6SL3203-0CJ28-6AA0
55	75	0BE34-5 . A0	FSF	
75	100	0BE35-5 . A0	FSF	6SE6400-3CC11-2FD0
90	125	0BE37-5 . A0	FSF	
				6SE6400-3CC11-7FD0

SINAMICS G120

Inverter chassis units 0.37 kW to 90 kW

Line-side power components
Recommended line components

Overview

The following table lists recommendations for further line-side components, such as fuses and circuit-breakers (line-side components dimensioned in accordance with IEC standards). The specified circuit-breakers are UL-certified. Fuses of type 3NA3

are recommended for European countries. The 3NE1 fuses are UL-compliant (corresponds to RU).

Further information about the listed fuses and circuit-breakers can be found in Catalogs LV 1 and LV 1 T.

Selection and ordering data

Rated output		SINAMICS G120 Power Modules PM240		Fuse		Circuit-breakers
kW	hp	Type 6SL3224-...	Frame size	Type 3NA3 Order No.	Type 3NE1 (RU) Order No.	Order No.
380 ... 480 V 3 AC						
0.37	0.50	0BE13-7UA0	FSA	3NA3803	UL-listed fuses such as the Class NON fuse series from Bussmann are required for North American countries.	3RV1021-1CA10
0.55	0.75	0BE15-5UA0	FSA			3RV1021-1DA10
0.75	1.0	0BE17-5UA0	FSA			3RV1021-1FA10
1.1	1.5	0BE21-1UA0	FSA			3RV1021-1GA10
1.5	2	0BE21-5UA0	FSA			3RV1021-1JA10
2.2	3	0BE22-2 . A0	FSB	3NA3805		3RV1021-1KA10
3.0	4	0BE23-0 . A0	FSB			3RV1021-4AA10
4.0	5	0BE24-0 . A0	FSB	3NA3807		3RV1021-4BA10
7.5	10	0BE25-5 . A0	FSC			3RV1031-4EA10
11.0	15	0BE27-5 . A0	FSC			3RV1031-4FA10
15.0	20	0BE31-1 . A0	FSC	3NA3812		3RV1031-4HA10
18.5	25	0BE31-5 . A0	FSD	3NA3820	3NE1817-0	3RV1042-4KA10
22	30	0BE31-8 . A0	FSD	3NA3822	3NE1818-0	
30	40	0BE32-2 . A0	FSD	3NA3824	3NE1820-0	3RV1042-4MA10
37	50	0BE33-0 . A0	FSE	3NA3830	3NE1021-0	3VL1712-.DD33-....
45	60	0BE33-7 . A0	FSE	3NA3832	3NE1022-0	3VL1716-.DD33-....
55	75	0BE34-5 . A0	FSF	3NA3836	3NE1224-0	3VL3720-.DC36-....
75	100	0BE35-5 . A0	FSF	3NA3140	3NE1225-0	3VL3725-.DC36-....
90	125	0BE37-5 . A0	FSF	3NA3144	3NE1227-0	3VL4731-.DC36-....

SINAMICS G120

Inverter chassis units 0.37 kW to 90 kW

Line-side power components Recommended line components

Selection and ordering data (continued)

Rated output		SINAMICS G120 Power Modules PM250		Fuse		Circuit-breakers
kW	hp	Type 6SL3225-...	Frame size	Type 3NA3 Order No.	Type 3NE1 (RU) Order No.	Order No.
380 ... 480 V 3 AC						
7.5	10	OBE25-5AA0	FSC	3NA3807	UL-listed fuses such as the Class NON fuse series from Bussmann are required for North American countries.	3RV1031-4EA10
11.0	15	OBE27-5AA0	FSC	3NA3812		3RV1031-4FA10
15.0	20	OBE31-1AA0	FSC	3NA3814		3RV1031-4HA10
18.5	25	OBE31-5AA0	FSD	3NA3820	3NE1817-0	3RV1042-4KA10
22	30	OBE31-8AA0	FSD	3NA3822	3NE1818-0	
30	40	OBE32-2AA0	FSD	3NA3824	3NE1820-0	3RV1042-4MA10
37	50	OBE33-0AA0	FSE	3NA3830	3NE1021-0	3VL1712-DD33-....
45	60	OBE33-7AA0	FSE	3NA3832	3NE1022-0	3VL1716-DD33-....
55	75	OBE34-5AA0	FSF	3NA3836	3NE1224-0	3VL3720-DC36-....
75	100	OBE35-5AA0	FSF	3NA3140	3NE1225-0	3VL3725-DC36-....
90	125	OBE37-5AA0	FSF	3NA3144	3NE1227-0	3VL4731-DC36-....

Rated output		SINAMICS G120 Power Modules PM260		Fuse		Circuit-breakers
kW	hp	Type 6SL3225-...	Frame size	Type 3NA3 Order No.	Type 3NE1 (RU) Order No.	Order No.
660 ... 690 V 3 AC						
11.0	15	OBH27-5 . A0	FSD	3NA3120-6	–	3RV1041-4FA10
15.0	20	OBH31-1 . A0	FSD			
18.5	25	OBH31-5 . A0	FSD			
30	40	OBH32-2 . A0	FSF	3NA3122-6		3RV1041-4JA10
37	50	OBH33-0 . A0	FSF			3RV1041-4KA10
55	75	OBH33-7 . A0	FSF	3NA3130-6		3RV1041-4MA10

SINAMICS G120

Inverter chassis units 0.37 kW to 90 kW

DC link components
Braking resistors

Overview



Example: braking resistors for Power Modules, frame sizes FSA and FSC

Excess power in the DC link is dissipated via the braking resistor. The braking resistors are intended for use with PM240 Power Modules which feature an integrated brake chopper, but cannot regenerate energy to the supply system. For regenerative operation, e.g. the braking of a rotating mass with high moment of inertia, a braking resistor must be connected to convert the resulting energy into heat.

The braking resistors can be installed at the side next to the PM240 Power Modules. The braking resistors for the FSA and FSB frame sizes are designed as base components. If the PM240 Power Modules of the FSA or FSB frame size are operated without line reactor, the braking resistors can also be installed under the Power Modules.

The braking resistors for the power modules of the FSC to FSF frame sizes should be placed outside the control cabinet or outside the control room in order to dissipate the resulting heat loss from the area of the power modules, thereby allowing a corresponding reduction in the level of air conditioning required.

Every braking resistor is designed with a temperature switch (UL-listed). The temperature switch can be evaluated to prevent consequential damage if the braking resistor overheats.

3

Technical specifications

Line voltage 380 V ... 480 V 3 AC	Braking resistor			
		6SE6400-4BD11-0AA0	6SL3201-0BE12-0AA0	6SE6400-4BD16-5CA0
Resistor	W	390	160	56
Rated power P_{DB}	kW	0.1	0.2	0.65
Peak power P_{max}	kW	2	4	11
Power connections		Shielded cable	Shielded cable	Shielded cable
• Conductor cross-section	mm ²	3 × 2.5	3 × 2.5	3 × 2.5
• Length	m	0.5	0.5	0.9
Thermostatic switch (NC contact) Max. contact load		250 V AC/2.5 A	250 V AC/2.5 A	250 V AC/2.5 A
Degree of protection		IP20	IP20	IP20
Frame size		FSA	FSB	FSC
Dimensions				
• Width	mm	72	153	185
• Height	mm	230	329	285
• Depth	mm	43.5	43.5	150
Possible as base component		Yes	Yes	No
Weight, approx.	kg	1	2	3.8
Suitable for PM240 Power Module	Type	6SL3224-0BE13-7UA0 6SL3224-0BE15-5UA0 6SL3224-0BE17-5UA0 6SL3224-0BE21-1UA0 6SL3224-0BE21-5UA0	6SL3224-0BE22-2.A0 6SL3224-0BE23-0.A0 6SL3224-0BE24-0.A0	6SL3224-0BE25-5.A0 6SL3224-0BE27-5.A0 6SL3224-0BE31-1.A0
Frame size		FSA	FSB	FSC

SINAMICS G120

Inverter chassis units 0.37 kW to 90 kW

DC link components Braking resistors

Technical specifications (continued)

Line voltage 380 V ... 480 V 3 AC	Braking resistor			
		6SE6400-4BD21-2DA0	6SE6400-4BD22-2EA0	6SE6400-4BD24-0FA0
Resistor	W	27	15	8.2
Rated power P_{DB}	kW	1.2	2.2	4
Peak power P_{max}	kW	24	44	80
Power connections		M6 screw studs	M6 screw studs	M6 screw studs
Thermostatic switch (NC contact) Max. contact load		250 V AC/2.5 A	250 V AC/2.5 A	250 V AC/0.2 A
Type of protection		IP20	IP20	IP20
Frame size		FSD	FSE	FSF
Dimensions				
• Width	mm	270	270	395
• Height	mm	515	645	650
• Depth	mm	175	175	315
Possible as base component		No	No	No
Weight, approx.	kg	7.4	10.6	16.7
Suitable for PM240 Power Module	Type	6SL3224-0BE31-5.A0 6SL3224-0BE31-8.A0 6SL3224-0BE32-2.A0	6SL3224-0BE33-0.A0 6SL3224-0BE33-7.A0	6SL3224-0BE34-5.A0 6SL3224-0BE35-5.A0 6SL3224-0BE37-5.A0
Frame size		FSD	FSE	FSF

Selection and ordering data

Rated output		SINAMICS G120 Power Module <u>PM240</u>		Braking resistor
kW	hp	Type 6SL3224-...	Frame size	Order No.
380 ... 480 V 3 AC				
0.37	0.50	0BE13-7UA0	FSA	6SE6400-4BD11-0AA0
0.55	0.75	0BE15-5UA0	FSA	
0.75	1.0	0BE17-5UA0	FSA	
1.1	1.5	0BE21-1UA0	FSA	
1.5	2	0BE21-5UA0	FSA	
2.2	3	0BE22-2 . A0	FSB	6SL3201-0BE12-0AA0
3.0	4	0BE23-0 . A0	FSB	
4.0	5	0BE24-0 . A0	FSB	
7.5	10	0BE25-5 . A0	FSC	6SE6400-4BD16-5CA0
11.0	15	0BE27-5 . A0	FSC	
15.0	20	0BE31-1 . A0	FSC	
18.5	25	0BE31-5 . A0	FSD	6SE6400-4BD21-2DA0
22	30	0BE31-8 . A0	FSD	
30	40	0BE32-2 . A0	FSD	
37	50	0BE33-0 . A0	FSE	6SE6400-4BD22-2EA0
45	60	0BE33-7 . A0	FSE	
55	75	0BE34-5 . A0	FSF	6SE6400-4BD24-0FA0
75	100	0BE35-5 . A0	FSF	
90	125	0BE37-5 . A0	FSF	

SINAMICS G120

Inverter chassis units 0.37 kW to 90 kW

Load-side power components Output reactors

Overview



Example: Output reactors for Power Modules frame sizes FSA and FSB

Output reactors reduce the voltage loading on the motor windings. At the same time, the capacitive charge/discharge currents, which place an additional load on the power section when long motor cables are used, are reduced.

Output reactors are only provided for the PM240 and PM250 Power Modules. An output reactor is not required for the PM260 Power Module due to its integrated sine-wave filter.

The maximum permissible output frequency is 150 Hz when an output reactor is used – the pulse frequency must not exceed 4 kHz.

The output reactor must be installed as close as possible to the Power Module.

Output reactors are approved for use only in conjunction with “Vector” and “U/f control” modes.

Technical specifications

Line voltage 380 ... 480 V 3 AC	Output reactor (for a 4 kHz pulse frequency)					
	6SE6400-3TC00-4AD2					
Rated current	A	4	4	4	4	4
Power loss	kW	0.005	0.005	0.005	0.005	0.005
Connection to the Power Module		Cable	Cable	Cable	Cable	Cable
• Conductor cross-section		4 × AWG16 (1.5 mm ²)	4 × AWG16 (1.5 mm ²)	4 × AWG16 (1.5 mm ²)	4 × AWG16 (1.5 mm ²)	4 × AWG16 (1.5 mm ²)
• Length, approx.	m	0.3	0.3	0.3	0.3	0.3
Motor connection		Screw terminals	Screw terminals	Screw terminals	Screw terminals	Screw terminals
• Conductor cross-section	mm ²	6	6	6	6	6
PE connection		M5 screw stud	M5 screw stud	M5 screw stud	M5 screw stud	M5 screw stud
Max. length of cable between output reactor and motor						
• Shielded	m	100	100	100	100	100
• Unshielded	m	150	150	150	150	150
Dimensions						
• Width	mm	75.5	75.5	75.5	75.5	75.5
• Height	mm	200	200	200	200	200
• Depth	mm	110	110	110	110	110
Possible as base component		Yes	Yes	Yes	Yes	Yes
Degree of protection		IP00	IP00	IP00	IP00	IP00
Weight, approx.	kg	2	2	2	2	2
Suitable for PM240 Power Module	Type	6SL3224-0BE13-7UA0	6SL3224-0BE15-5UA0	6SL3224-0BE17-5UA0	6SL3224-0BE21-1UA0	6SL3224-0BE21-5UA0
Rated output of the Power Module	kW	0.37	0.55	0.75	1.1	1.5
Rated current I_{rated} of the Power Module	A	1.3	1.7	2.2	3.1	4.1
Frame size		FSA	FSA	FSA	FSA	FSA

SINAMICS G120

Inverter chassis units 0.37 kW to 90 kW

Load-side power components Output reactors

Technical specifications (continued)

Line voltage 380 ... 480 V 3 AC	Output reactor (for a 4 kHz pulse frequency)						
		6SL3202-0AE21-0CA0			6SL3202-0AJ23-2CA0		
Rated current	A	9.4	9.4	9.4	32	32	32
Power loss	kW	0.02	0.02	0.02	0.06	0.06	0.06
Connection to the Power Module		Cable	Cable	Cable	Cable	Cable	Cable
• Conductor cross-section		4 × AWG14 (1.5 mm ²)	4 × AWG14 (1.5 mm ²)	4 × AWG14 (1.5 mm ²)	4 × AWG14 (1.5 mm ²)	4 × AWG14 (1.5 mm ²)	4 × AWG14 (1.5 mm ²)
• Length, approx.	m	0.4	0.4	0.4	0.35	0.35	0.35
Motor connection		Screw terminals	Screw terminals	Screw terminals	Screw terminals	Screw terminals	Screw terminals
• Conductor cross-section	mm ²	6	6	6	6	6	6
PE connection		M5 screw stud	M5 screw stud	M5 screw stud	M5 screw stud	M5 screw stud	M5 screw stud
Max. length of cable between output reactor and motor							
• Shielded	m	100	100	100	100	100	100
• Unshielded	m	150	150	150	150	150	150
Dimensions							
• Width	mm	154	154	154	189	189	189
• Height	mm	270	270	270	334	334	334
• Depth	mm	70	70	70	80	80	80
Possible as base component		Yes	Yes	Yes	Yes	Yes	Yes
Degree of protection		IP00	IP00	IP00	IP00	IP00	IP00
Weight, approx.	kg	4.4	4.4	4.4	9.1	9.1	9.1
Suitable for PM240 Power Module	Type	6SL3224-0BE22-2UA0 6SL3224-0BE22-2AA0	6SL3224-0BE23-0UA0 6SL3224-0BE23-0AA0	6SL3224-0BE24-0UA0 6SL3224-0BE24-0AA0	6SL3224-0BE25-5UA0 6SL3224-0BE25-5AA0	6SL3224-0BE27-5UA0 6SL3224-0BE27-5AA0	6SL3224-0BE31-1UA0 6SL3224-0BE31-1AA0
Suitable for PM250 Power Module	Type	–	–	–	6SL3225-0BE25-5AA0	6SL3225-0BE27-5AA0	6SL3225-0BE31-1AA0
Rated output of the Power Module	kW	2.2	3	4	7.5	11	15
Rated current I_{rated} of the Power Module	A	5.9	7.7	10.2	18	25	32
Frame size		FSB	FSB	FSB	FSC	FSC	FSC

SINAMICS G120

Inverter chassis units 0.37 kW to 90 kW

Load-side power components Output reactors

Technical specifications (continued)

Line voltage 380 ... 480 V 3 AC	Output reactor (for a 4 kHz pulse frequency)					
		6SE6400-3TC05-4DD0	6SE6400-3TC03-8DD0	6SE6400-3TC05-4DD0	6SE6400-3TC08-0ED0	6SE6400-3TC07-5ED0
Rated current	A	68	45	68	104	90
Power loss	kW	0.2	0.2	0.2	0.17	0.27
Connection to the Power Module		Flat connection for M6 cable lug	Flat connection for M6 cable lug	Flat connection for M6 cable lug	Flat connection for M6 cable lug	Flat connection for M6 cable lug
Motor connection		Flat connection for M6 cable lug	Flat connection for M6 cable lug	Flat connection for M6 cable lug	Flat connection for M6 cable lug	Flat connection for M6 cable lug
PE connection		M6 screw	M6 screw	M6 screw	M6 screw	M6 screw
Max. length of cable between output reactor and motor						
• Shielded	m	200	200	200	200	200
• Unshielded	m	300	300	300	300	300
Dimensions						
• Width	mm	225	225	225	225	270
• Height	mm	210	210	210	210	248
• Depth	mm	150	179	150	150	209
Possible as base component		No	No	No	No	No
Degree of protection		IP00	IP00	IP00	IP00	IP00
Weight, approx.	kg	10.7	16.1	10.7	10.4	24.9
Suitable for PM240 Power Module	Type	6SL3224-0BE31-5UA0 6SL3224-0BE31-5AA0	6SL3224-0BE31-8UA0 6SL3224-0BE31-8AA0	6SL3224-0BE32-2UA0 6SL3224-0BE32-2AA0	6SL3224-0BE33-0UA0 6SL3224-0BE33-0AA0	6SL3224-0BE33-7UA0 6SL3224-0BE33-7AA0
Suitable for PM250 Power Module	Type	6SL3225-0BE31-5AA0	6SL3225-0BE31-8AA0	6SL3225-0BE32-2AA0	6SL3225-0BE33-0AA0	6SL3225-0BE33-7AA0
Rated output of the Power Module	kW	18.5	22	30	37	45
Rated current I_{rated} of the Power Module	A	38	45	60	75	90
Frame size		FSD	FSD	FSD	FSE	FSE

SINAMICS G120

Inverter chassis units 0.37 kW to 90 kW

Load-side power components Output reactors

Technical specifications (continued)

Line voltage 380 ... 480 V 3 AC	Output reactor (for a 4 kHz pulse frequency)			
		6SE6400-3TC14-5FD0	6SE6400-3TC15-4FD0	6SE6400-3TC14-5FD0
Rated current	A	178	178	178
Power loss	kW	0.47	0.25	0.47
Connection to the Power Module		Flat connection for M8 cable lug	Flat connection for M8 cable lug	Flat connection for M8 cable lug
Motor connection		Flat connection for M8 cable lug	Flat connection for M8 cable lug	Flat connection for M8 cable lug
PE connection		M8 screw	M6 screw	M8 screw
Max. length of cable between output reactor and motor				
• Shielded	m	200	200	200
• Unshielded	m	300	300	300
Dimensions				
• Width	mm	350	270	350
• Height	mm	321	248	321
• Depth	mm	288	209	288
Possible as base component		No	No	No
Degree of protection		IP00	IP00	IP00
Weight, approx.	kg	51.5	24	51.5
Suitable for PM240 Power Module	Type	6SL3224-0BE34-5UA0 6SL3224-0BE34-5AA0	6SL3224-0BE35-5UA0 6SL3224-0BE35-5AA0	6SL3224-0BE37-5UA0 6SL3224-0BE37-5AA0
Suitable for PM250 Power Module	Type	6SL3225-0BE34-5AA0	6SL3225-0BE35-5AA0	6SL3225-0BE37-5AA0
Rated output of the Power Module	kW	55	75	90
Rated current I_{rated} of the Power Module	A	110	145	178
Frame size		FSF	FSF	FSF

SINAMICS G120

Inverter chassis units 0.37 kW to 90 kW

Load-side power components
Output reactors

Selection and ordering data

Rated output		SINAMICS G120 Power Modules <u>PM240</u>		Output reactor
kW	hp	Type 6SL3224-...	Frame size	Order No.
380 ... 480 V 3 AC				
0.37	0.50	0BE13-7UA0	FSA	6SE6400-3TC00-4AD2
0.55	0.75	0BE15-5UA0	FSA	
0.75	1.0	0BE17-5UA0	FSA	
1.1	1.5	0BE21-1UA0	FSA	
1.5	2	0BE21-5UA0	FSA	
2.2	3	0BE22-2 . A0	FSB	6SL3202-0AE21-0CA0
3.0	4	0BE23-0 . A0	FSB	
4.0	5	0BE24-0 . A0	FSB	
7.5	10	0BE25-5 . A0	FSC	6SL3202-0AJ23-2CA0
11.0	15	0BE27-5 . A0	FSC	
15.0	20	0BE31-1 . A0	FSC	
18.5	25	0BE31-5 . A0	FSD	6SE6400-3TC05-4DD0
22	30	0BE31-8 . A0	FSD	6SE6400-3TC03-8DD0
30	40	0BE32-2 . A0	FSD	6SE6400-3TC05-4DD0
37	50	0BE33-0 . A0	FSE	6SE6400-3TC08-0ED0
45	60	0BE33-7 . A0	FSE	6SE6400-3TC07-5ED0
55	75	0BE34-5 . A0	FSF	6SE6400-3TC14-5FD0
75	100	0BE35-5 . A0	FSF	6SE6400-3TC15-4FD0
90	125	0BE37-5 . A0	FSF	6SE6400-3TC14-5FD0
Rated output		SINAMICS G120 Power Modules <u>PM250</u>		Output reactor
kW	hp	Type 6SL3225-...	Frame size	Order No.
380 ... 480 V 3 AC				
7.5	10	0BE25-5 . A0	FSC	6SL3202-0AJ23-2CA0
11.0	15	0BE27-5 . A0	FSC	
15.0	20	0BE31-1 . A0	FSC	
18.5	25	0BE31-5 . A0	FSD	6SE6400-3TC05-4DD0
22	30	0BE31-8 . A0	FSD	6SE6400-3TC03-8DD0
30	40	0BE32-2 . A0	FSD	6SE6400-3TC05-4DD0
37	50	0BE33-0 . A0	FSE	6SE6400-3TC08-0ED0
45	60	0BE33-7 . A0	FSE	6SE6400-3TC07-5ED0
55	75	0BE34-5 . A0	FSF	6SE6400-3TC14-5FD0
75	100	0BE35-5 . A0	FSF	6SE6400-3TC15-4FD0
90	125	0BE37-5 . A0	FSF	6SE6400-3TC14-5FD0

SINAMICS G120

Inverter chassis units 0.37 kW to 90 kW

Supplementary system components

Basic Operator Panel BOP

Overview



The Basic Operator Panel BOP can be used to commission drives, monitor drives in operation and input individual parameter settings. Values and units are displayed via a 5-digit display.

One BOP can be used for several inverters. It is plugged directly into the Control Unit.

The BOP provides a function for time-saving copying of parameters. A parameter set of one inverter can be saved and then loaded to another inverter.

Integration



Control Unit with mounted Basic Operator Panel BOP

Selection and ordering data

	Order No.
Basic Operator Panel BOP	6SL3255-0AA00-4BA1

Supplementary system components

PC inverter connection kit

Overview

For controlling and commissioning an inverter directly from a PC if the appropriate software (STARTER) has been installed.

This is an isolated RS232 adapter board for a reliable point-to-point connection to a PC with a serial RS232 interface. A USB/RS232 adapter can be used as an alternative.

The scope of supply includes a 9-pin Sub-D connector and an RS232 standard cable (3 m) and the STARTER commissioning tool on CD-ROM.

With these, the inverter can be

- parameterized (commissioning, optimization),
- monitored (diagnostics) and
- controlled (master control via STARTER for test purposes).

Selection and ordering data

	Order No.
PC inverter connection kit including a 9-pin Sub-D connector, an RS232 standard cable (3 m), and the STARTER commissioning tool on CD-ROM.	6SL3255-0AA00-2AA1

SINAMICS G120

Inverter chassis units 0.37 kW to 90 kW

Supplementary system components

Brake relay

Overview



The Brake Relay allows the Power Module to be connected to an electromechanical motor brake, thereby allowing the motor brake to be driven directly by the Control Unit.

Selection and ordering data

	Order No.
Brake Relay including cable harness for connection to the Power Module	6SL3252-0BB00-0AA0

Integration

The Brake Relay has the following interfaces:

- A switch contact (NO contact) to control the motor brake solenoid
- A connection for the cable harness (CTRL) for connection to the Power Module

The Brake Relay can be installed on the shield bonding plate near the power terminals of the Power Module.

The supplied brake relay includes the cable harness for connection with the power module.

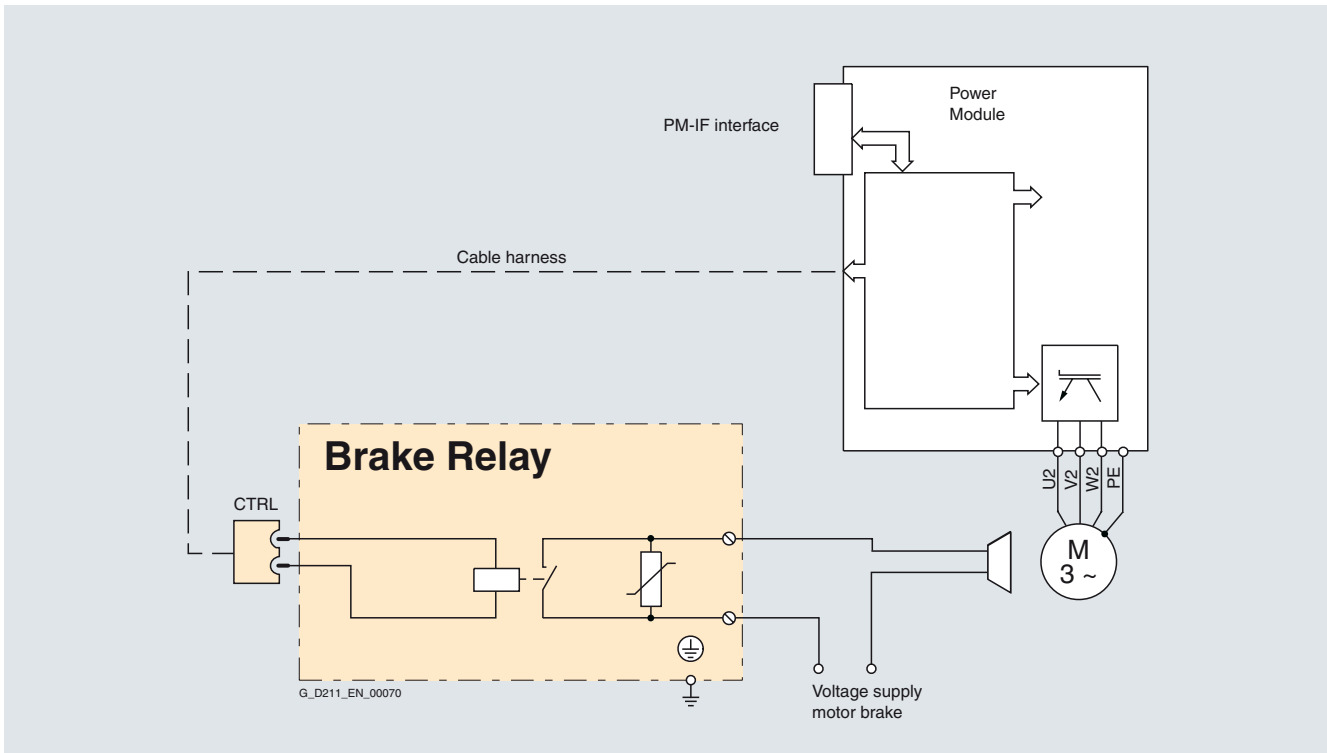

Connection example for Brake Relay

Technical specifications

	Brake Relay
Max. switching capability of the NO contact	440 V AC / 3.5 A 30 V DC / 12 A
Max. conductor cross-section	2.5 mm ²
Degree of protection	IP20
Dimensions	
• Width	68 mm
• Height	63 mm
• Depth	33 mm
Weight, approx.	0.17 kg

SINAMICS G120

Inverter chassis units 0.37 kW to 90 kW

Supplementary system components Safe Brake Relay

Overview



The Safe Brake Relay allows the Power Module to be safely connected to an electromechanical motor brake, allowing the brake to be directly and safely controlled by the Control Unit in accordance with EN 954-1, safety category 3, and IEC 61508 SIL 2.

Selection and ordering data

	Order No.
Safe Brake Relay including cable harness for connection to the Power Module	6SL3252-0BB01-0AA0

Integration

The Safe Brake Relay has the following interfaces:

- A two-channel transistor output stage to control the motor brake solenoid
- A connection for a 24 V DC voltage supply
- A connection for the cable harness (CTRL) for connection to the Power Module

The Safe Brake Relay can be mounted on the shield bonding plate near the power terminals of the Power Module.

The supplied safe brake relay includes the cable harness for connection with the power module.

The 24 V DC solenoid of the motor brake is directly connected to the Safe Brake Relay. External overvoltage limiters are not required.

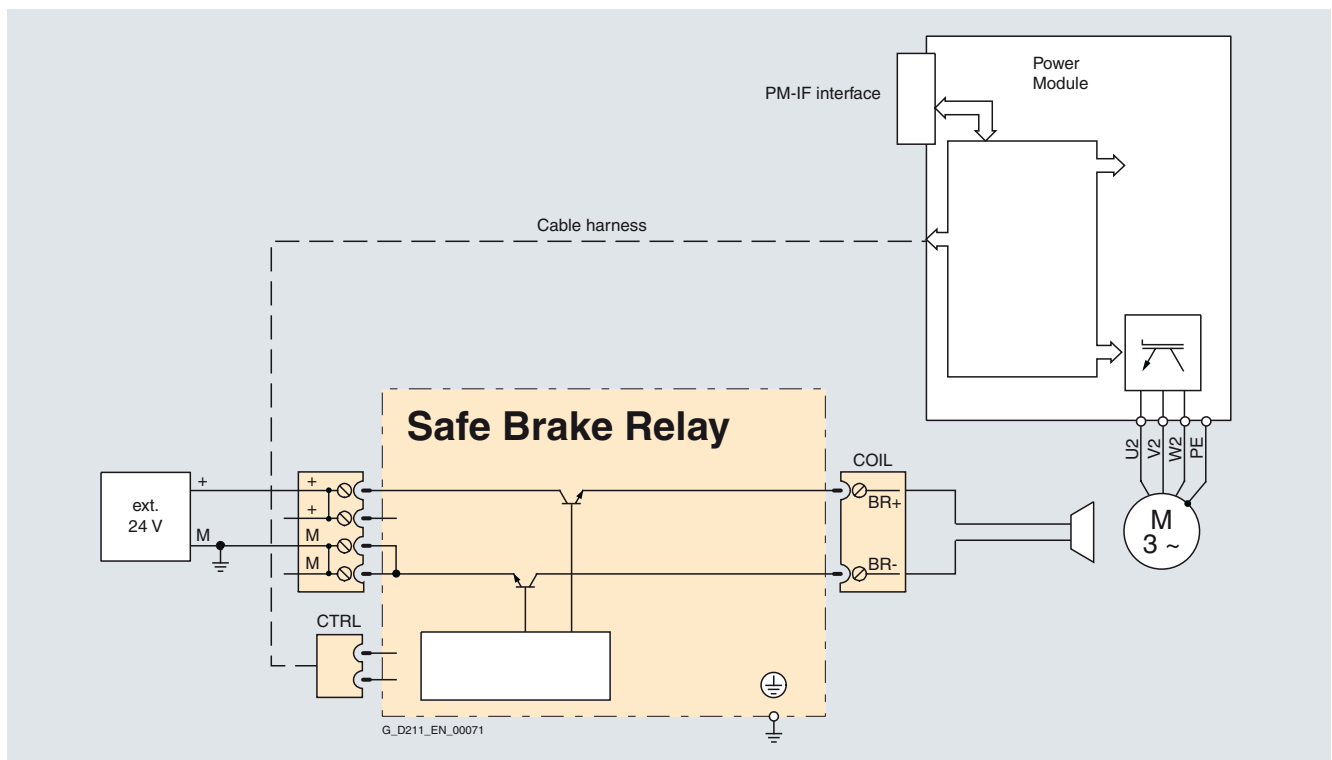

Typical connection of Safe Brake Relay

Technical specifications

	Safe Brake Relay
Supply voltage	20.4 ... 28.8 V DC Recommended rated value of the supply voltage 26 V DC (to equalize and compensate for the voltage drop along the feeder cable to the 24 V DC solenoid of the motor brake)
Max. current requirement of motor brake	2 A
Max. current requirement at 24 V DC	0.005 A + current requirement of brake

	Safe Brake Relay
Max. conductor cross-section	2.5 mm ²
Degree of protection	IP20
Dimensions	
• Width	68 mm
• Height	63 mm
• Depth	33 mm
Weight, approx.	0.17 kg

Supplementary system components Adapter for DIN rail attachment

Overview

The adapter for DIN rail attachment can be used to mount inverters of frame sizes FSA and FSB on DIN rails (2 units with a center-to-center distance of 100 mm).

Furthermore, the motor cable shield connection and other cable shields required for DIN-rail mounting of inverters comply with the same standards for emissions and conducted emissions as if the inverter were directly installed in a control cabinet.

The adapter for inverter frame size FSA can be used to mount inverters singly or with matching line filter.

The adapter for inverter frame size FSB can be used to mount inverters with or without an integrated line filter.

Selection and ordering data

Adapter for DIN rail attachment	Order No.
• for Power Module frame size FSA	6SL3262-1BA00-0BA0
• for Power Module frame size FSB	6SL3262-1BB00-0BA0

Supplementary system components Shield connection kit

Overview

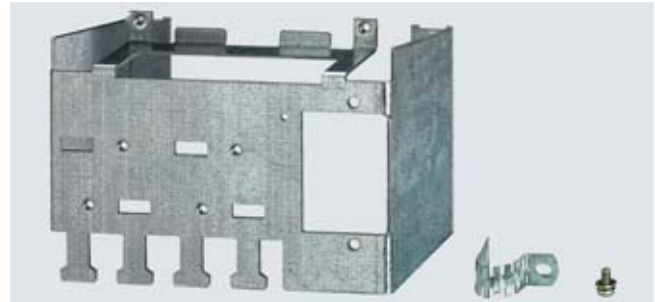

Example of shield connection kit for Power Module frame size FSB

The shield connection kit

- makes it easier to bond the shields of supply and control cables
- provides mechanical strain relief
- ensures optimum EMC performance

The shield connection kit includes

- a shield bonding plate for the required Power Module
- a shield bonding plate for a Control Unit
- connection elements and clamps for mounting
- mounting device for Brake Relay or Safe Brake Relay – frame sizes FSB to FSF

Selection and ordering data

Shield connection kit	Order No.
• for Power Modules PM240/PM250	
- Frame size FSA	6SL3262-1AA00-0BA0
- Frame size FSB	6SL3262-1AB00-0DA0
- Frame size FSC	6SL3262-1AC00-0DA0
- Frame sizes FSD and FSE	6SL3262-1AD00-0DA0
- Frame size FSF	6SL3262-1AF00-0DA0
• for Power Modules PM260	
- Frame size FSD	6SL3262-1FD00-0CA0
- Frame size FSF (available soon)	6SL3262-1FF00-0CA0

SINAMICS G120

Inverter chassis units 0.37 kW to 90 kW

Supplementary system components NEMA1 mounting kit

Overview

The SINAMICS G120 inverter chassis units are designed to comply with type "UL OPEN". The NEMA1 mounting kit is required to obtain a type 1 NEMA housing.

An inverter with the NEMA1 mounting kit can be operated in compliance with NEMA1 directives (NEMA 250-2003):

- Wall mounting without control cabinet in enclosed areas
- Protection against falling dirt ingress
- Personnel protection against accidental contact with housing

The NEMA1 mounting kit comprises the following components:

- Screen termination plate
- Screening plate for the Control Unit
- Cable duct
- Cover hood
- Cover

Selection and ordering data

NEMA1 mounting kit	Order No.
• for Power Module frame size FSA (available soon)	6SL3262-1CA00-0BA0
• for Power Module frame size FSB (available soon)	6SL3262-1CB00-0DA0
• for Power Module frame size FSC (available soon)	6SL3262-1CC00-0DA0
• for Power Module frame sizes FSD and FSE	6SL3262-1CD00-0DA0
• for Power Module frame size FSF	6SL3262-1CF00-0DA0

SINAMICS G120D

Distributed frequency inverters 0.75 kW to 7.5 kW

4



4/2 Distributed frequency inverters SINAMICS G120D

- 4/2 Overview
- 4/3 Benefits
- 4/3 Application
- 4/3 Design
- 4/4 Configuration
- 4/5 Technical specifications

4/6 CU240D Control Units

- 4/6 Overview
- 4/6 Design
- 4/7 [Selection and ordering data](#)
- 4/7 Accessories
- 4/8 Technical specifications

4/10 PM250D Power Modules

- 4/10 Overview
- 4/10 [Selection and ordering data](#)
- 4/10 Accessories
- 4/11 Integration
- 4/12 Technical specifications
- 4/15 Characteristic curves
- 4/16 Dimensional drawings



SINAMICS G120D

Distributed frequency inverters 0.75 kW to 7.5 kW

Distributed frequency inverters SINAMICS G120D

Overview

The new SINAMICS G120D distributed frequency inverter series is the solution for demanding drive tasks especially in the field of conveyor systems. SINAMICS G120D supports bump-free, closed-loop speed control of three-phase asynchronous motors and fulfills all the requirements of conveyor system applications from simple frequency control through to demanding vector control. With its well-thought-out modular type of construction to the IP65 degree of protection, it is seamlessly integrated into the plant and supports a high plant availability and minimized spare parts inventories. The innovative power module concept with regenerative feedback capability helps to save energy. Safety functions that are unique worldwide support enhanced plant concepts with increased productivity. This drive can be optimally integrated into the Siemens TIA world of automation via PROFIBUS.

With different device versions (frame sizes FSA to FSC) in an output range of 0.75 kW to 7.5 kW, it is suitable for a wide variety of drive solutions.



Example for SINAMICS G120D, frame size FSA, comprising Power Module PM250D and fail-safe Control Unit CU240D DP-F

Reasons for using distributed drive systems

- Modular drive solutions providing standardized mechatronic elements that can be individually tested
- No need for a control cabinet, resulting in a smaller space requirement and less air-conditioning
- Long cables between the inverter and motor can be avoided (which means lower output losses, reduced interference emission and lower costs for shielded cables and additional filters)
- Distributed configurations offer considerable benefits for conveyor systems with their extensive coverage (e.g. in the automotive and logistics sectors)

Modularity

SINAMICS G120D is a modular inverter system to IP65 degree of protection comprising a variety of functional units. The two main units are

- Control Unit (CU)
- Power Module (PM)

The Control Unit controls and monitors the Power Module and the connected motor in several different control modes. The digital inputs and digital outputs on the device support the simple wiring of sensors and actuators directly on the drive. The input signals can either be directly linked within the Control Unit and trigger local responses automatically or they can be transferred to the central controller via PROFIBUS for processing within the context of the overall plant.

The Power Module supplies the motor in the power range 0.75 kW to 7.5 kW. The Power Module is controlled by a micro-processor in the Control Unit. State-of-the-art IGBT technology with pulse-width-modulation is used for highly reliable and flexible motor operation. It also features a range of functions offering a high degree of protection for the Power Module and motor. The unusual slimline type of construction is optimized for use directly in the plant. The Power Module also has the same drilling template for all outputs (constant footprint).

Safety integrated

The SINAMICS G120D distributed frequency inverters are available in a number of different variants for safety-oriented applications. All Power Modules are already designed for Safety Integrated. A Safety Integrated Drive can be created by combining a Power Module with the relevant Failsafe Control Unit.

The SINAMICS G120D fail-safe frequency inverter provides three safety functions, certified in accordance with EN 954-1, Cat. 3 and IEC 61508 SIL 2:

- Safe torque off (STO) to protect against active movement of the drive
- Safe Stop 1 (SS1) for continuous monitoring of a safe braking ramp
- Safely limited speed (SLS) for protection against dangerous movements on exceeding a speed limit

The functions "Safe Stop 1" and "Safely limited speed" can both be implemented without a motor sensor or encoder; the implementation cost is minimal. Existing plants can also be updated with safety technology without the need to change the motor or mechanical system.

The safety functions "Safely limited speed" and "Safe stop 1" are certified for asynchronous motors without encoders – these safety functions are not permitted for pull-through loads as in the case of lifting gear and winders.

STARTER drive/commissioning software

The STARTER (STARTER Version 4.1, SP1 and higher) drive/commissioning software supports the commissioning and maintenance of SINAMICS G120D inverters. The operator guidance combined with comprehensive, user-friendly functions for the relevant drive solution allow you to commission the device quickly and easily. The commissioning tool STARTER is included in the scope of supply of the Control Unit on CD-ROM.

SINAMICS G120D

Distributed frequency inverters 0.75 kW to 7.5 kW

Distributed frequency inverters SINAMICS G120D

Benefits

- Compact and space-saving design with slimline type of construction and identical drilling template for all outputs
- Wide output range from 0.75 to 7.5 kW.
- The safety functions make it easier to integrate drives into safety-oriented machines or plants
- The innovative circuit design (bidirectional input rectifier with "pared-down" DC link) allows the kinetic energy of a load to be fed back into the supply system. This feedback capability provides enormous potential for savings because generated energy no longer has to be converted into heat in a braking resistor. Braking resistors and reactors are not necessary – this is a particular advantage in terms of the space requirement and installation costs for the high IP65 degree of protection.
- Enhanced ruggedness and longer service life due to coating of the electronic modules
- Flexibility due to modularity for a future-oriented distributed drive concept to the high IP65 degree of protection
 - Every development stage of a component can improve the existing drive system
 - Module replacement when system is running (hot swapping)
 - The modules can be easily replaced, which makes the system extremely service friendly.
- Capable of communicating via PROFIBUS with PROFIdrive Profile 4.0
 - Reduced number of interfaces
 - Plant-wide engineering
 - Easy to handle
- The ability to connect up to six sensors and up to two actuators directly to the Control Unit means that almost all drive information can be directly managed; local preprocessing of the signals takes the load off the fieldbus.
- Integrated EMC filter of class A (according to EN 55011), integrated braking control (400 V 1 AC rectified, corresponds to 180 V DC) and integrated motor protection due to thermal motor model and evaluation of PTC or KTY 84 temperature sensors
- Software parameters for easy adaptation to 50 Hz or 60 Hz motors (IEC or NEMA motors)
- Easy replacement of devices and time-saving copying of parameters with the optional MMC memory card
- Engineering and commissioning with uniform engineering tools such as SIZER (Version 2.9 and higher), STARTER (Version 4.1, SP1 and higher) and Drive ES: Ensure rapid engineering and easy commissioning – STARTER is integrated in STEP 7 with Drive ES Basic with all the advantages of central data storage and totally integrated communication
- Certified worldwide for compliance with CE, UL, cUL, C-tick and Safety Integrated according to EN 954-1, Cat. 3 and IEC 61508 SIL 2

Application

SINAMICS G120D is ideally suited for demanding conveyor system applications in the industrial environment for which a distributed drive with communications capability is required. This applies in particular to the automotive sector, e.g. assembly lines.

SINAMICS G120D is also suitable for further high-performance applications, e.g. in the airport sector, food and beverages industry (dry areas) and in distribution logistics (e.g. monorail overhead conveyors).

Design

The SINAMICS G120D distributed frequency inverters are modular frequency inverters for standard drives. Each SINAMICS G120D comprises two operative units – the Power Module and Control Unit.

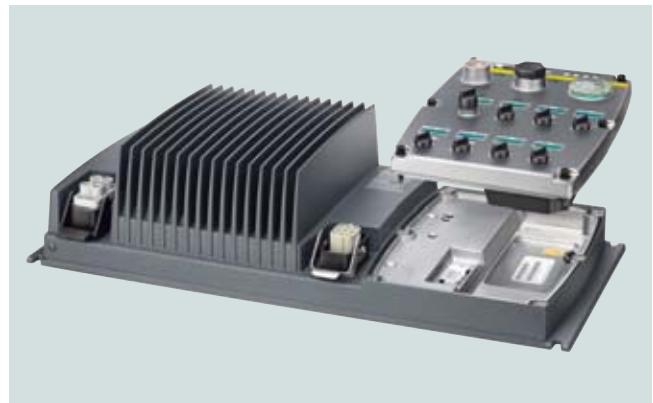

Power Module PM250D and Control Unit CU240D

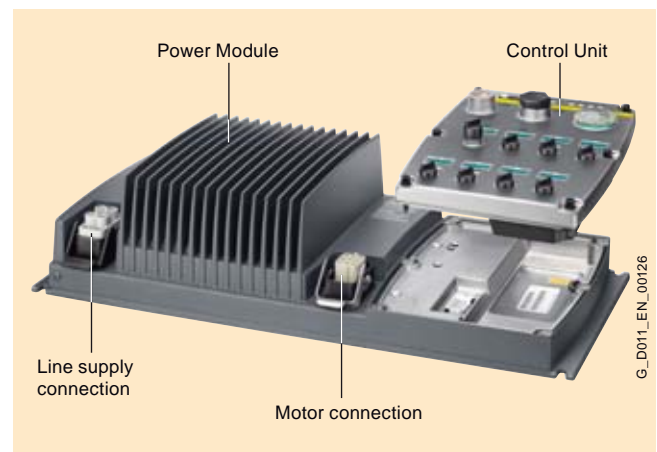

Power Module PM250D with line and motor connections and Control Unit CU240D

SINAMICS G120D

Distributed frequency inverters 0.75 kW to 7.5 kW

Distributed frequency inverters SINAMICS G120D

Design (continued)

Power Modules

The following Power Modules are available for SINAMICS G120D distributed frequency inverters:

PM250D Power Modules

PM250D Power Modules use an innovative circuit design which allows line-commutated energy recovery to the supply. This innovative circuit permits generator energy to be fed back into the supply system and, therefore, saves energy.

Accessories

Connector sets for line infeed and the outgoing motor feeder are available as accessories as well as pre-assembled motor cables for connection to the motor.

Control Units

The following Control Units are available for SINAMICS G120D distributed frequency inverters:

CU240D Control Units

The Control Unit performs closed-loop control functions for the inverter. In addition to control functions, the Control Unit can also perform other tasks which can be adapted to the relevant application by parameterization. A number of Control Units are available in different versions:

- CU240D DP
- CU240D DP-F
- CU240D PN (available soon)
- CU240D PN-F (available soon)

Accessories

- MMC memory card

The parameter settings for an inverter can be stored on the MMC memory card. When the plant is serviced, it is immediately ready for use again after, for example, replacement of the frequency inverter and transfer of the memory card data. The associated slot is located on the rear of the Control Unit.

- RS232 interface cable for communication with a PC

For controlling and commissioning an inverter directly from a PC if the appropriate software (STARTER Version 4.1, SP1 and higher) has been installed. The commissioning tool STARTER is included in the scope of supply of the Control Unit on CD-ROM.

- Spare parts kit

A spare parts kit is available which comprises small parts such as seals, cover caps, PROFIBUS address windows and screws.

Configuration

The following electronic configuration and engineering tools are available for SINAMICS G120D distributed frequency inverters:

SD configurator selection aid within the CA 01

The interactive catalog CA 01 – the offline mall of Siemens Automation and Drives (A&D) – contains over 100000 products with approximately 5 million potential drive system product variants. The SD configurator has been developed to facilitate selection of the correct motor and/or inverter from the wide spectrum of A&D SD products. The configurator is integrated in this catalog with the selection and configuration tools as a “selection guide” on CD 2 “Configuring”.

SIZER configuration tool

The SIZER PC tool provides an easy-to-use means of configuring the SINAMICS and MICROMASTER 4 drive family. It provides support when setting up the technologies involved in the hardware and firmware components required for a drive task. SIZER supports the complete configuration of the drive system, from simple individual drives to complex multi-axis applications. For SINAMICS G120D as from SIZER Version 2.9.

STARTER drive/commissioning software

The STARTER drive/commissioning software provides menu-guided assistance with commissioning, optimization and diagnostics. STARTER is not only designed for use on SINAMICS drives but also for MICROMASTER4 units and frequency inverters for the distributed I/O SIMATIC ET 200S FC. For SINAMICS G120D from STARTER Version 4.1, SP1.

Drive ES engineering system

Drive ES is the engineering system used to integrate Siemens drive technology into the SIMATIC automation world easily, efficiently and cost-effectively in terms of communication, configuration and data management. The STEP 7 Manager user interface provides the basis for this procedure. A variety of software packages, i.e. Drive ES Basic, Drive ES SIMATIC and Drive ES PCS 7, is available for SINAMICS.

SINAMICS G120D

Distributed frequency inverters 0.75 kW to 7.5 kW

Distributed frequency inverters SINAMICS G120D

Technical specifications

Unless explicitly specified otherwise, the following technical specifications are valid for the following components of the distributed SINAMICS G120D frequency inverters.

Mechanical data	
Vibratory load	
• Transport ¹⁾	EN 60068-2-6 5 ... 9 Hz: Constant deflection 3.1 mm 9 ... 200 Hz: Constant acceleration = 9.81 m/s ² (1 g)
• Operation	EN 60068-2-6 10 ... 58 Hz: Constant deflection 0.15 mm 58 ... 200 Hz: Constant acceleration = 19.62 m/s ² (2 g)
Shock load	
• Transport ¹⁾	EN 60068-2-27 147.15 m/s ² (15 g)/11 ms; 3 shocks in each axis and direction
• Operation	EN 60068-2-27 147.15 m/s ² (15 g)/11 ms; 3 shocks in each axis and direction
Ambient conditions	
Protection class	Class III (PELV) to EN 61800-5-1
Shock protection	Class I (with PE conductor system) to EN 61800-5-1
Permissible ambient and coolant temperature (air) during operation for Power Modules	-10 to +40 °C without derating, > 40 to 55 °C, see derating characteristics
Permissible ambient and coolant temperature (air) during operation for Control Units	-10 ... +55 °C with CU240D DP-F: 0 ... 40 °C up to 2000 m above sea level
Climatic ambient conditions	
• Storage ¹⁾	EN 60068-2-1 Temperature -40 ... +70 °C
• Transport ¹⁾	EN 60068-2-1 Temperature -40 ... +70 °C max. air humidity 95% at 40 °C
• Operation	EN 60068-2-2 Temperature -10 ... +40 °C without derating
Environmental class/harmful chemical substances	
• Operation	Class 3C2 to EN 60721-3-3
Degree of contamination	2 to EN 61800-5-1
Standards	
Standards conformance	UL, cUL, CE, c-tick
CE mark	To Low-Voltage Directive 73/23/EEC and Machinery Directive 89/37/EEC
EMC directive ²⁾	
• Frame sizes FSA to FSC with integrated line filter class A	Category C2 ³⁾ to EN 61800-3 (corresponds to class A to EN 55011)
Note: The EMC product standard EN 61800-3 does not apply directly to a frequency inverter but to a PDS (Power Drive System), which comprises the complete circuitry, motor and cables in addition to the inverter. The frequency inverters on their own do not generally require identification according to the EMC directive.	

¹⁾ In transport packaging.

²⁾ For further, general information, see also SINAMICS G110 sections "Technical specifications" and "Compliance with standards".

³⁾ With shielded motor cable up to 15 m.

SINAMICS G120D

Distributed frequency inverters 0.75 kW to 7.5 kW

CU240D Control Units

Overview



Example of CU240D DP-F Control Unit

The Control Unit performs closed-loop control functions for the inverter. In addition to control functions, the Control Unit can also perform other tasks which can be adapted to the relevant application by parameterization. Control Units are available in different versions:

- CU240D DP
- CU240D DP-F

Design

The Control Unit has the following connections:

- 24 V DC supply voltage
- PROFIBUS interface and DIP switch for PROFIBUS addressing and PROFIBUS terminating resistor
- 6 digital inputs for up to 6 sensors
- 2 digital outputs for up to 2 actuators
- Encoder interface for encoder feedback (HTL bipolar)
- Optical interface for connection of an RS232 interface cable for communication with a PC
- Slot for an MMC memory card at the rear to one side
- PM IF interface at the rear for connecting the Control Unit to the Power Module

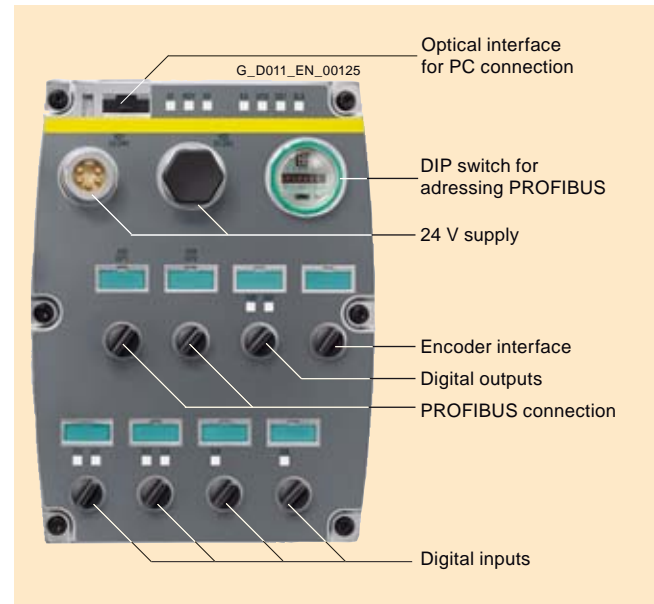

Connections for Control Unit CU240D DP-F

SINAMICS G120D

Distributed frequency inverters 0.75 kW to 7.5 kW

CU240D Control Units

Selection and ordering data

Communication	Digital inputs	Digital outputs	Encoder interfaces	Designation	Control unit Order No.
Standard					
PROFIBUS DP	6	2	1	CU240D DP	6SL3544-0FA20-1PA0
Fail-safe for Safety Integrated					
PROFIBUS DP	6	2	1	CU240D DP-F	6SL3544-0FA21-1PA0

Accessories

MMC memory card

The parameter settings for an inverter can be stored on the MMC memory card. When the plant is serviced, it is immediately ready for use again after, for example, replacement of the frequency inverter and transfer of the memory card data. The associated slot is located on the rear of the Control Unit.

	Order No.
MMC memory card	6SL3254-0AM00-0AA0

RS232 interface cable for communication with a PC

For controlling and commissioning an inverter directly from a PC over a point-to-point link if the appropriate software (STARTER, Version 4.1, SP1 and higher) has been installed. The start-up tool STARTER is included in the scope of supply of every Control Unit on CD-ROM.

	Order No.
RS232 interface cable for communication with a PC	3RK1922-2BP00

Spare parts kit

A spare parts kit can be ordered which comprises small parts such as replacement seals, cover caps, PROFIBUS address windows and screws.

	Order No.
Spare parts kit for SINAMICS G120D Control Units	6SL3500-0SK01-0AA0
comprising replacement seals, cover caps, PROFIBUS address windows and screws	

SINAMICS G120D

Distributed frequency inverters 0.75 kW to 7.5 kW

CU240D Control Units

Technical specifications

	Control Unit CU240D DP 6SL3544-0FA20-1PA0	Control Unit CU240D DP-F 6SL3544-0FA21-1PA0
Electrical data		
Operating voltage	External 24 V DC	External 24 V DC
Interfaces		
Digital inputs	6	6
Digital outputs (0.5 A, supplied over switched 24 V DC)	2	2
Bus interface	PROFIBUS DP	PROFIBUS DP, PROFIsafe
Encoder interfaces	1	1
PTC/KTY interface (connected via Power Module)	✓	✓
Activation of a mechanical holding brake (connected via Power Module)	✓	✓
MMC memory card slot	✓	✓
RS232 interface (connected with RS232 interface cable via the optical interface of the Control Unit)	✓	✓
Safety functions		
Integral safety functions to Category 3 of EN 954-1 and SIL2 of IEC 61508	–	<ul style="list-style-type: none"> • Safe Stop 1 – SS1 • Safely Limited Speed (SLS) • Safe Torque Off (STO) <p>The safety functions “Safely limited speed” and “Safe stop 1” are certified for asynchronous motors without encoders – these safety functions are not permitted for pull-through loads as in the case of lifting gear and winders.</p>
Open-loop and closed-loop control functions		
V/f linear/quadratic/parameterizable	✓	✓
V/f with flux current control (FCC)	✓	✓
Vector control, encoderless	✓	✓
Vector control with encoder	✓	✓
Torque control, encoderless	✓	✓
Torque control with encoder	✓	✓

SINAMICS G120D

Distributed frequency inverters 0.75 kW to 7.5 kW

CU240D Control Units

Technical specifications (continued)

	Control Unit CU240D DP 6SL3544-0FA20-1PA0	Control Unit CU240D DP-F 6SL3544-0FA21-1PA0
Software functions		
Fixed frequencies	16, programmable	16, programmable
Signal interconnection with BICO technology	✓	✓
Automatic restart following line failure or fault	✓	✓
Positioning deceleration ramp	✓	✓
Slip compensation	✓	✓
Free function blocks (FFB) for logic and arithmetic operations	✓	✓
Ramp smoothing	✓	✓
3 switchable drive data sets	✓	✓
3 switchable command data sets (CDS) (manual/auto)	✓	✓
Flying restart	✓	✓
JOG	✓	✓
Technology controller (PID)	✓	✓
Thermal motor protection	✓	✓
Thermal inverter protection	✓	✓
Setpoint specification	✓	✓
Motor identification	✓	✓
Motor holding brake	✓	✓
Mechanical specifications and environmental operating conditions		
Degree of protection	IP65	IP65
Operating temperature	-10 ... +55 °C (14 ... 131 °F)	0 ... 40 °C (32 ... 104 °F)
Storage temperature	-40 ... +70 °C (-40 ... +158 °F)	-40 ... +70 °C (-40 ... +158 °F)
Relative humidity	< 95% RH, non-condensing	< 95% RH, non-condensing
Dimensions		
• Width	150 mm	150 mm
• Height	210 mm	210 mm
• Depth	40 mm	40 mm
Weight, approx.	0.7 kg	0.7 kg

SINAMICS G120D

Distributed frequency inverters 0.75 kW to 7.5 kW

PM250D Power Modules

Overview

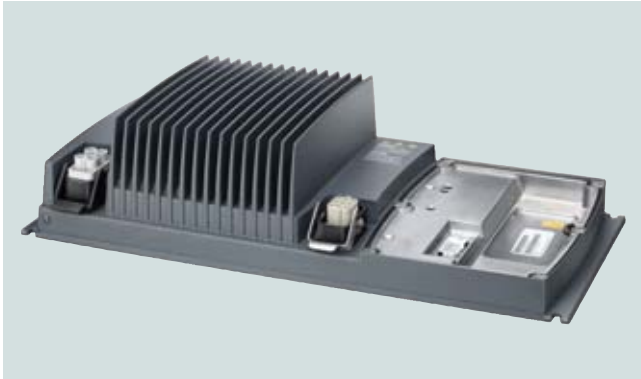

Example of Power Module PM250D FSA

The regenerative feedback capability of the PM250D Power Module in generating mode (electronic braking) means that energy is returned to the supply system and not destroyed in a braking resistor. This saves space, time-consuming dimensioning of the braking resistor as well as its wiring. Generated heat is also reduced.

An innovative circuit design reduces the supply harmonics. A line reactor is not required. This saves space and costs for engineering and procurement.

The PM250D Power Module is also designed for safety-sensitive applications. In conjunction with a Safety Control Unit, the drive can be turned into a Safety Integrated Drive (see Control Units).

Selection and ordering data

Rated output ¹⁾		Rated output current ²⁾	Input current	Frame size	SINAMICS G120D Power Module PM250D with integrated line filter class A Order No.
kW	hp	A	A		
380 to 480 V 3 AC					
0.75	1	2.2	2.1	FSA	6SL3525-0PE17-5AA0
1.5	2	4.1	3.8	FSA	6SL3525-0PE21-5AA0
3	4	7.7	7.2	FSB	6SL3525-0PE23-0AA0
4	5	10.2	9.5	FSC	6SL3525-0PE24-0AA0
5.5	7.5	13.2	12.2	FSC	6SL3525-0PE25-5AA0
7.5	10	19.0	17.7	FSC	6SL3525-0PE27-5AA0

Accessories

Connector sets for the line supply

	Order No.
Connector set for Han Q4/2 power supply	
• 2.5 mm ²	3RK1911-2BE50
• 4 mm ²	3RK1911-2BE10
• 6 mm ²	3RK1911-2BE30

Preassembled motor cables and connector set for the connection between the Power Module and the motor

	Order No.
Pre-assembled motor cable, with HAN Q8 connector on one end, shielded	
• Length 1.5 m	6ES7194-1LA01-0AA0
• Length 3 m	6ES7194-1LB01-0AA0
• Length 5 m	6ES7194-1LC01-0AA0
• Length 10 m	6ES7194-1LD01-0AA0
Connector set for motor cable, shielded, HAN Q8	6ES7194-1AB01-0XA0

¹⁾ Rated output based on the rated output current I_{rated} . The rated output current I_{rated} is based on the loading for high overload (high overload HO).

²⁾ The rated output current I_{rated} is based on the loading for high overload (high overload HO).

SINAMICS G120D

Distributed frequency inverters 0.75 kW to 7.5 kW

PM250D Power Modules

Integration

PM250D Power Modules communicate with the Control Unit via the PM-IF interface.

PM250D Power Modules feature the following interfaces as standard:

- PM-IF interface for connection of the PM250D Power Module and Control Unit.
- Motor is connected through HAN Q8 (male) including activation of the holding brake and temperature sensor
- Network is connected through HAN Q4/2 (female)

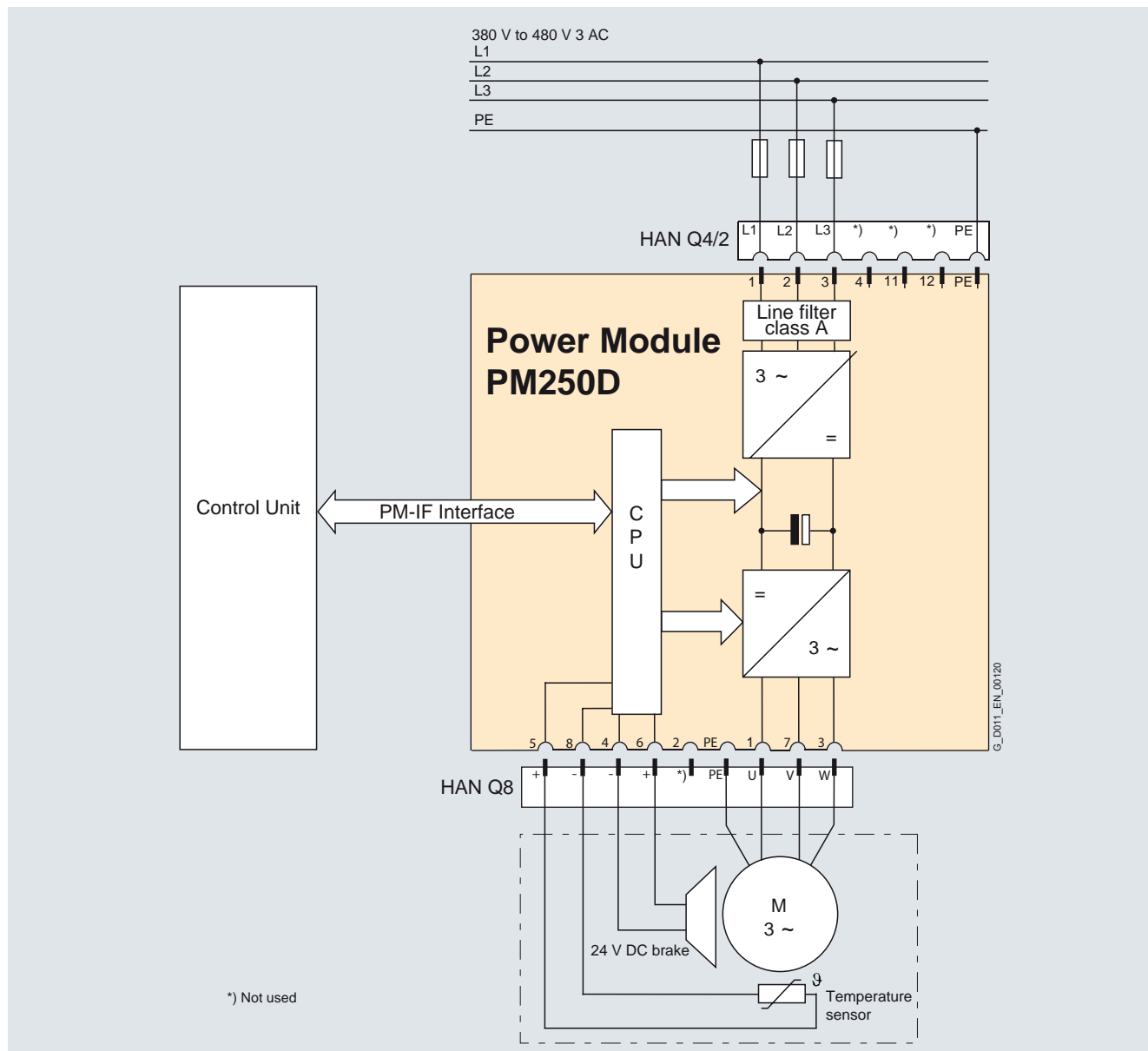

Connection diagram for PM250D Power Module with integrated line filter class A

SINAMICS G120D

Distributed frequency inverters 0.75 kW to 7.5 kW

PM250D Power Modules

Technical specifications

General technical data

PM250D Power Modules	
Line operating voltage	380 to 480 V 3 AC ±10%
Line requirements	≤ 1%
Line short circuit voltage u_k	
Input frequency	47 ... 63 Hz
Output frequency	
• Control type V/f	0 ... 650 Hz
• Control type Vector	0 ... 200 Hz
Pulse frequency	4 kHz (standard), for higher pulse frequencies, see derating data
Power factor	0.95
Inverter efficiency	95 ... 97%
Control factor	87%
Overload capability	
• High overload (HO)	<ul style="list-style-type: none"> • Average maximum rated output current during a cycle time of 300 s • 1.5 × rated output current (i.e. 150% overload) over 60 s at a cycle time of 300 s • 2 × rated output current (i.e. 200% overload) over 3 s at a cycle time of 300 s
Electromagnetic Compatibility	Integrated line filter class A according to EN 55011
Possible braking methods	Regenerative feedback in generating mode; integrated braking signal 180 V DC (corresponds to 1 AC 400 V rectified)
Degree of protection	IP65
Operating temperature	
• with standard Control Unit	-10 ... +40 °C (14 ... 104 °F) without derating, > 40 ... 55 °C, see derating characteristics
• with fail-safe Control Unit	0 ... 40 °C (32 ... 104 °F)
Storage temperature	-40 ... +70 °C (-40 ... +158 °F)
Permitted mounting position	Wall mounting and free-standing
Relative humidity	< 95% RH, non-condensing
Cooling	FSA and FSB: Convection FSC: Air cooling as required through built-in fan
Installation altitude	Up to 1000 m above sea level without derating, > 1000 m see derating characteristics
Standard SCCR (Short Circuit Current Rating) ¹⁾	10 kA
Protective functions	<ul style="list-style-type: none"> • Undervoltage • Overvoltage • Overload • Ground fault • Short-circuit • Stall prevention • Motor blocking protection • Motor overtemperature • Inverter overtemperature • Parameter interlock
Standards conformance	UL, cUL, CE, c-tick
CE mark	To Low-Voltage Directive 73/23/EEC and Machinery Directive 98/37/EEC

¹⁾ Applies to industrial control cabinet installations to NEC article 409/UL 508A. For further information, visit us on the Internet at: <http://support.automation.siemens.com/WW/view/en/23995621>

SINAMICS G120D

Distributed frequency inverters 0.75 kW to 7.5 kW

PM250D Power Modules

Technical specifications (continued)

Line voltage 3 AC 380 to 480 V	PM250D Power Modules			
		6SL3525-0PE17-5AA0	6SL3525-0PE21-5AA0	6SL3525-0PE23-0AA0
Rated output current $I_{\text{rated}}^{1)}$	A	2.2	4.1	7.7
Output current I_{max}	A	4.4	8.2	15.4
Rated power	kW	0.75	1.5	3
Rated pulse frequency	kHz	4	4	4
Efficiency η		0.97	0.97	0.97
Power loss	kW	0.047	0.061	0.103
Cooling air requirement	m ³ /s	0.004	0.005	0.009
Sound pressure level	dB(A)	–	–	–
Rated input current ²⁾	A	2.1	3.8	7.2
Line supply connection U1/L1, V1/L2, W1/L3, PE		HAN Q4/2 (male)	HAN Q4/2 (male)	HAN Q4/2 (male)
• Conductor cross-section	mm ²	1.5 ... 6	1.5 ... 6	2.5 ... 6
Motor connection U2, V2, W2, PE, brake, tem- perature sensor		HAN Q8 (female)	HAN Q8 (female)	HAN Q8 (female)
• Conductor cross-section	mm ²	1 ... 4	1 ... 4	2.5 ... 4
Motor cable length, max.	m	15	15	15
Degree of protection		IP65	IP65	IP65
Dimensions				
• Width	mm	450	450	450
• Height	mm	210	210	210
• Depth	mm	110	110	180
Frame size		FSA	FSA	FSB
Weight, approx.	kg	5.7	5.7	8

¹⁾ The rated output current I_{rated} is based on the loading for high overload (high overload HO).

²⁾ The input current depends on the motor load and line impedance. The input currents apply for rated power loading for a line impedance corresponding to $u_k = 1\%$.

SINAMICS G120D

Distributed frequency inverters 0.75 kW to 7.5 kW

PM250D Power Modules

Technical specifications (continued)

Line voltage 380 to 480 V 3 AC	PM250D Power Modules			
	6SL3525-0PE24-0AA0	6SL3525-0PE25-5AA0	6SL3525-0PE27-5AA0	
Rated output current I_{rated} ¹⁾	A	10.2	13.2	19
Output current I_{max}	A	20.4	26.4	38
Rated power	kW	4	5.5	7.5
Rated pulse frequency	kHz	4	4	4
Efficiency η		0.97	0.97	0.97
Power loss	kW	0.141	0.209	0.295
Cooling air requirement	m ³ /s	0.012	0.018	0.025
Sound pressure level	dB(A)	74.5	74.5	74.5
Rated input current ²⁾	A	9.5	12.2	17.7
Line supply connection U1/L1, V1/L2, W1/L3, PE		HAN Q4/2 (male)	HAN Q4/2 (male)	HAN Q4/2 (male)
• Conductor cross-section	mm ²	2.5 ... 6	4 ... 6	4 ... 6
Motor connection U2, V2, W2, PE, brake, temperature sensor		HAN Q8 (female)	HAN Q8 (female)	HAN Q8 (female)
• Conductor cross-section	mm ²	2.5 ... 4	4	4
Motor cable length, max.	m	15	15	15
Degree of protection		IP65	IP65	IP65
Dimensions				
• Width	mm	450	450	450
• Height	mm	210	210	210
• Depth	mm	220	220	220
Frame size		FSC	FSC	FSC
Weight, approx.	kg	8.5	8.5	8.5

¹⁾ The rated output current I_{rated} is based on the loading for high overload (high overload HO).

²⁾ The input current depends on the motor load and line impedance. The input currents apply for rated power loading for a line impedance corresponding to $u_k = 1\%$.

SINAMICS G120D

Distributed frequency inverters 0.75 kW to 7.5 kW

PM250D Power Modules

Characteristic curves

Derating data

Pulse frequency

Rated output at 400 V 3 AC		Rated output current in A at a switching frequency of						
kW	hp	4 kHz	6 kHz	8 kHz	10 kHz	12 kHz	14 kHz	16 kHz
0.75	1.0	2.2	1.9	1.5	1.3	1.1	1.0	0.9
1.5	2.0	4.1	3.5	2.9	2.5	2.1	1.8	1.6
3.0	4.0	7.7	6.5	5.4	4.6	3.9	3.5	3.1
4.0	5.0	10.2	8.7	7.1	6.1	5.1	4.6	4.1
5.5	7.5	13.2	11.2	9.2	7.9	6.6	5.9	5.3
7.5	10	19	16.2	13.3	11.4	9.5	8.6	7.6

Ambient temperature

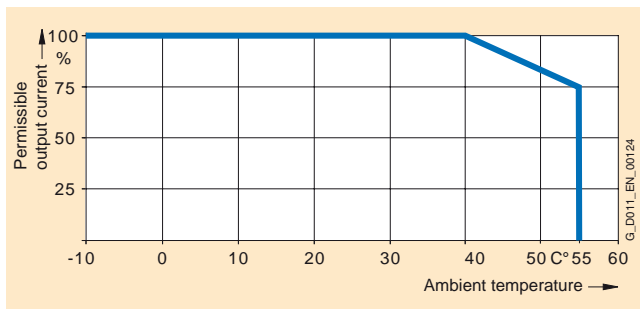

Installation altitude

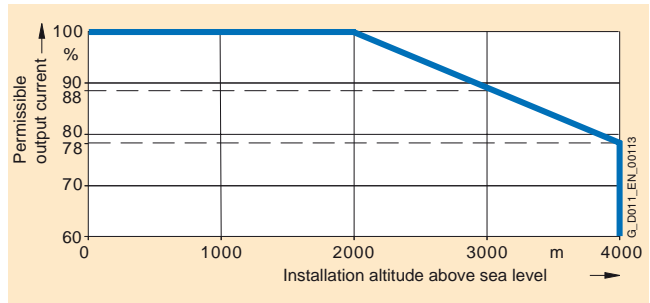
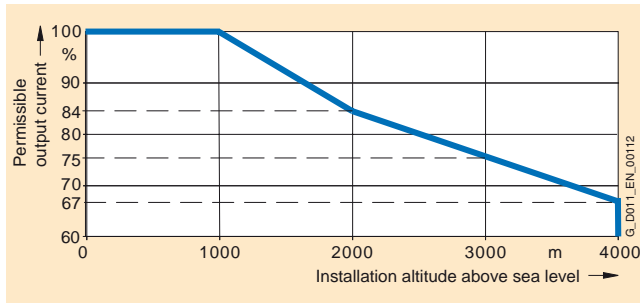

SINAMICS G120D

Distributed frequency inverters 0.75 kW to 7.5 kW

PM250D Power Modules

Dimensional drawings

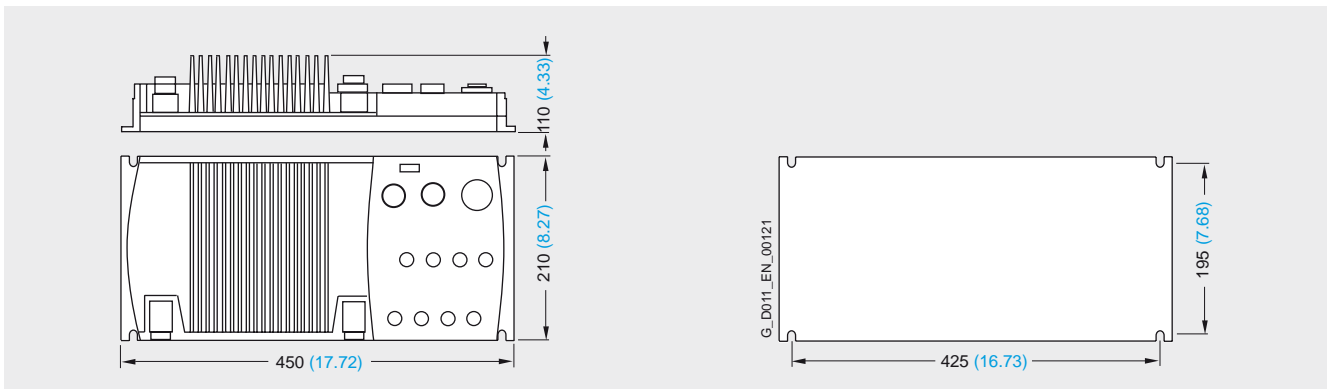

Power Module PM250D frame size FSA with integrated line filter class A and plugged-in Control Unit

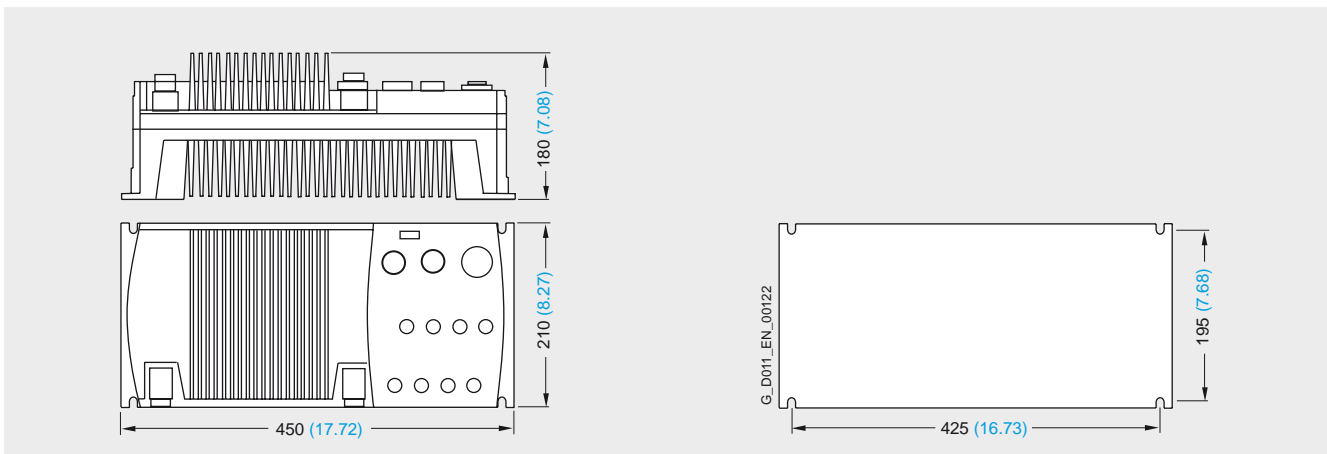

Power Module PM250D frame size FSB with integrated line filter class A and plugged-in Control Unit

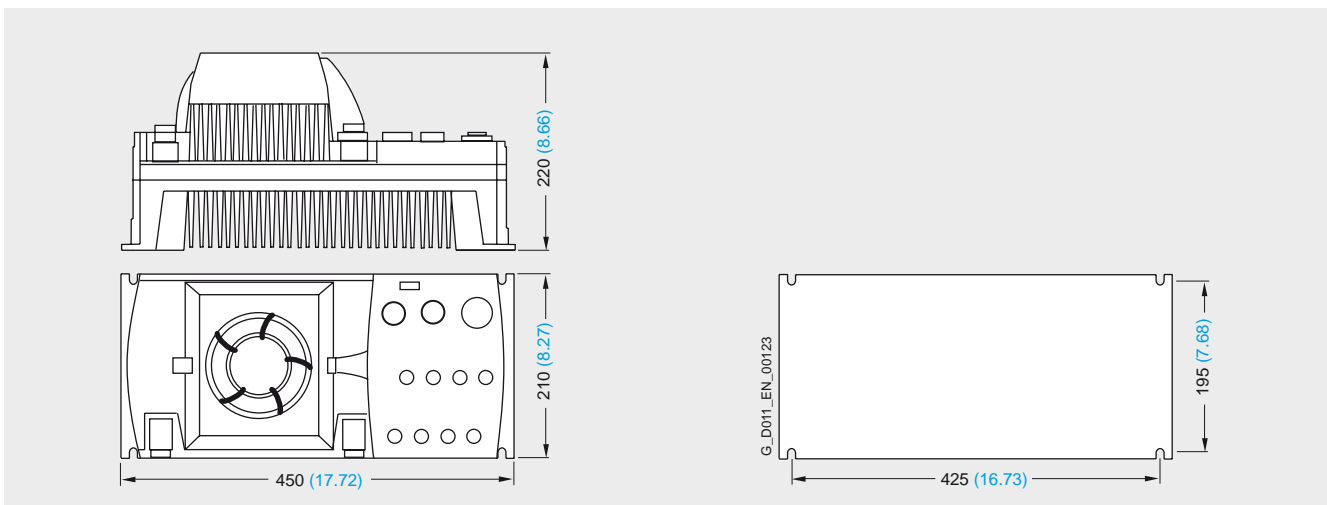

Power Module PM250D frame size FSC with integrated line filter class A and plugged-in Control Unit

Fixing with 4 M5 studs, 4 M5 nuts, 4 M5 washers

Tightening torque: 2.5 Nm (22.1 lbf-in)

Ventilation clearance required (for wall mounting) at top and bottom:
150 mm (5.9 inches)

All dimensions in mm (values in brackets are in inches).

Engineering Tools

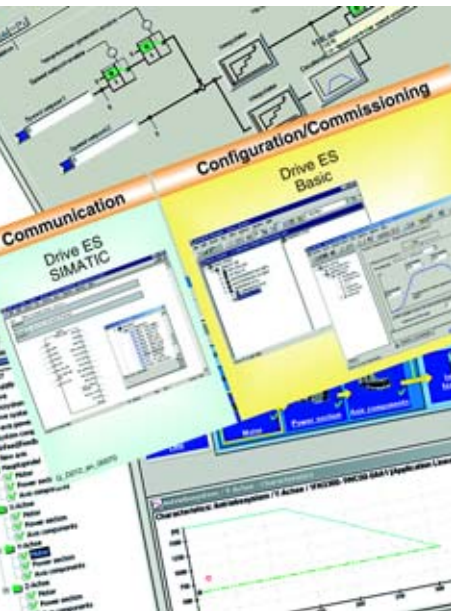

5/2	SD configurator selection aid
5/2	Overview
5/2	Selection and ordering data
5/2	Further information
5/3	SIZER configuration tool
5/3	Overview
5/3	Selection and ordering data
5/4	STARTER drive/commissioning tool
5/4	Overview
5/4	Integration
5/4	Selection and ordering data
5/4	Further information
5/5	Engineering System Drive ES
5/5	Overview
5/5	Selection and ordering data



SINAMICS G110/SINAMICS G120

Engineering Tools

SD configurator selection aid

Overview



The interactive catalog CA 01 – the offline mall of Siemens Automation and Drives (A&D) – on CD2 “Configuring” contains over 100000 products with approximately 5 million potential drive system product variants.

The SD configurator has been developed to facilitate selection of the correct motor and/or inverter from the wide spectrum of A&D SD products. It is integrated as a “selection help” in this catalog. The SD configurator is used to help locate the correct drive solution and delivers both the correct order number and relevant documentation.

It can display operating instructions, factory test certificates, terminal box documentation, etc. and generates data sheets, dimension drawings and a start-up calculation for the relevant products. It can also be used to identify a suitable inverter for the selected motor. 3D models in .stp format are also available.

The comprehensive help system not only explains the program functions, but also provides access to detailed technical background knowledge.

Product Range

The SD configurator covers the product spectrum of low-voltage motors (energy-saving and increased-safety motors) with associated documentation and dimension drawings, low-voltage inverters in the MICROMASTER 4 range, SINAMICS G110 and G120 converter chassis units and frequency inverters for the SIMATIC ET 200S FC distributed I/Os.

Hardware and software requirements

- PC with 500 MHz CPU or faster
- Operating systems
 - Windows 98/ME
 - Windows 2000
 - Windows XP
 - Windows NT (Service Pack 6 and higher)
- At least 256 MB RAM user memory
- 1024 × 768 graphics with over 256 colors/small fonts
- CD-ROM drive
- Windows-compatible sound card
- Windows-compatible mouse

Installation

You can install this catalog on your hard disk or network directly from the CD-ROM/DVD as a light or full version.

Selection and ordering data

Description	Order No.
Interactive catalog CA 01 on <u>CD-ROM</u> including selection help SD configurator, English	E86060-D4001-A110-C5-7600
Interactive catalog CA 01 on <u>DVD</u> including selection help SD configurator, English	E86060-D4001-A510-C5-7600

Further information

The interactive catalog CA 01 can be ordered from the relevant Siemens sales office or via the Internet:

<http://www.siemens.com/automation/CA01>

Links to hints, tricks and downloads for functional or content updates can be found at this address.

For technical advice and hotline support, you can also contact our hotline for catalog CA 01:

Tel.: +49 (0) 180 50 50 22 2

Email: adsupport@siemens.com

SINAMICS G110/SINAMICS G120

Engineering Tools

SIZER configuration tool

Overview

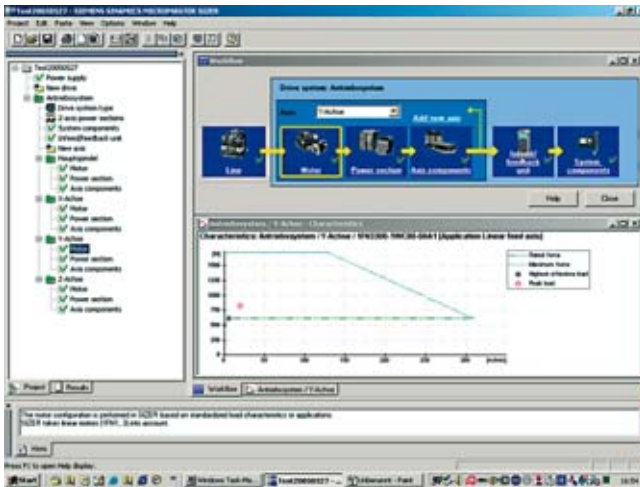

The SIZER configuration tool provides an easy-to-use means of configuring the SINAMICS and MICROMASTER 4 drive families, as well as the SINUMERIK solution line CNC control and SIMOTION Motion Control. It provides support when setting up the technologies involved in the hardware and firmware components required for a drive task. SIZER supports the complete configuration of the drive system, from simple individual drives to complex multi-axis applications.

SIZER supports all of the engineering steps in one workflow:

- Selection of the power supply
- Motor design as a result of load configuration
- Calculation of the drive components
- Selecting the required accessories
- Selection of the line-side and motor-side power options

When SIZER was being designed, particular importance was placed on high usability and a universal, function-based approach to the drive task. The extensive user guidance makes using the tool easy. Status information keeps you continually informed of the progress of the configuration process.

The SIZER user interface is available in English and German.

The drive configuration is saved in a project. In the project, the components and functions used are displayed in a hierarchical tree structure.

The project view permits the configuration of drive systems and the copying/inserting/modifying of drives already configured.

The configuration process produces the following results:

- A parts list of the components required
- Technical specifications
- Characteristic curves
- Comments on system reactions
- Location diagram and dimension drawings

These results are displayed in a results tree and can be reused for documentation purposes.

User support is provided by the technological online help menu, which provides the following information:

- Detailed technical data
- Information about the drive systems and their components
- Decision-making criteria for the selection of components

Minimum hardware and software requirements

PG or PC with Pentium™ II 400 MHz (Windows™ 2000), Pentium™ III 500 MHz (Windows™ XP)

256 MB RAM (512 MB recommended)

At least 990 MB of free hard disk space

An additional 100 MB of free hard disk space on Windows system drive

Monitor resolution, 1024×768 pixels

Windows™ 2000 SP2, XP Professional SP1, XP Home Edition SP1

Microsoft Internet Explorer 5.5 SP2

Selection and ordering data

	Order No.
SINAMICS MICROMASTER SIZER configuration tool	6SL3070-0AA00-0AG0
English/German	

SINAMICS G110/SINAMICS G120

Engineering Tools

STARTER drive/commissioning tool

Overview

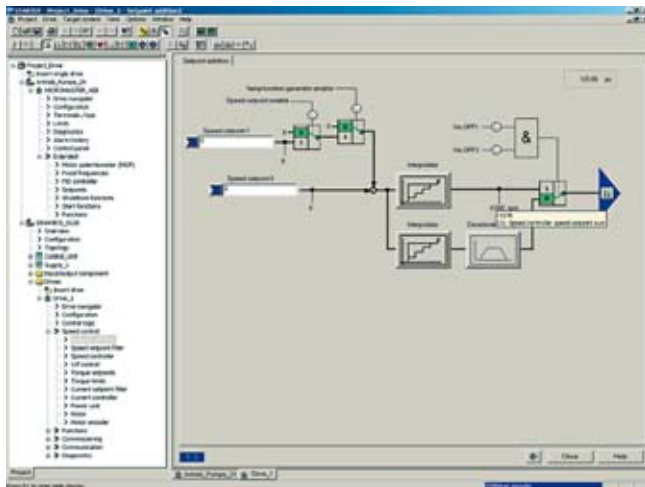

The easy-to-use STARTER drive/commissioning software can be used to:

- Start up
- Optimize and
- Diagnostics.

This software can be operated either as a standalone PC application or can be integrated into the SCOUT engineering system (on SIMOTION) or STEP 7 (with Drive ES Basic). The basic functions and handling are the same regardless.

In addition to the SINAMICS drives, the current version of STARTER also supports MICROMASTER 4 devices and inverters for the SIMATIC ET 200S FC distributed I/O system.

The project wizards can be used to create the drives within the structure of the project tree.

Beginners are supported by solution-based dialog guidance, whereby a standard graphics-based display maximizes clarity when setting the drive parameters.

First commissioning is guided by wizards, which make all the basic settings in the drive. This ensures that even though only a small number of parameter settings have been made, the drive configuration has already progressed far enough to permit axis movement.

The individual settings required are made using graphics-based parameterization screen forms, which also display the mode of operation.

Examples of individual settings that can be made include:

- Terminals
- Bus interface
- Setpoint channel (e.g. fixed setpoints)
- Closed-loop speed control (e.g. ramp-function generator, limits)
- BICO interconnections
- Diagnostics

Experts can gain rapid access to the individual parameters via the Expert List and do not have to navigate dialogs.

In addition, the following functions are available for optimization purposes:

- Self-optimization
- Trace (depending on drive)

Diagnostics functions provide information about:

- Control/status words
- Parameter status
- Operating conditions
- Communication states

Performance

- Easy to use: Only a small number of settings need to be made for successful first commissioning: axis turning
- Solution-based dialog-based user guidance simplifies commissioning
- Self-optimization functions reduce manual effort for optimization
- The built-in trace function provides optimum support during commissioning, optimization and troubleshooting.

Minimum hardware and software requirements

PG device or PC with Pentium™ II 400 MHz (Windows™ 2000), Pentium™ III 500 MHz (Windows™ XP)

256 MB RAM (512 MB recommended)

Monitor resolution, 1024×768 pixels

Windows™ 2000 SP3, XP Professional SP1

Microsoft Internet Explorer 5.01

Integration

A PROFIBUS communications module and a connecting cable are required to make the communication link between the PG/PC and a control unit.

For example, PROFIBUS communications module CP 5512 (PCMCIA type 2 card + adapter with 9-pin SUB-D socket for connection to PROFIBUS). For Windows 2000/XP Professional and PCMCIA 32)

Order No.: 6GK1551-2AA00

and connecting cable between CP 5512 and PROFIBUS
Order No.: 6ES7901-4BD00-0XA0

PC inverter connecting kits are available for MICROMASTER 4, SINAMICS G110 and SINAMICS G120 for a safe point-to-point connection to the PC.

Order No. for MICROMASTER 4: 6SE6400-1PC00-0AA0

(the scope of supply includes a 9-pin Sub-D connector and an RS232 standard cable, 3 m)

Order No. for SINAMICS G110 and SINAMICS G120:
6SL3255-0AA00-2AA1

(the scope of supply includes a 9-pin Sub-D connector and an RS232 standard cable, 3 m, and the STARTER startup tool on CD-ROM)

Selection and ordering data

	Order No.
STARTER commissioning tool for SINAMICS and MICROMASTER	6SL3072-0AA00-0AG0
English/German/French/Italian	

Further information

The commissioning tool STARTER is also available on the Internet unter

<http://www4.ad.siemens.de/WW/view/de/10804985/133100>

Overview

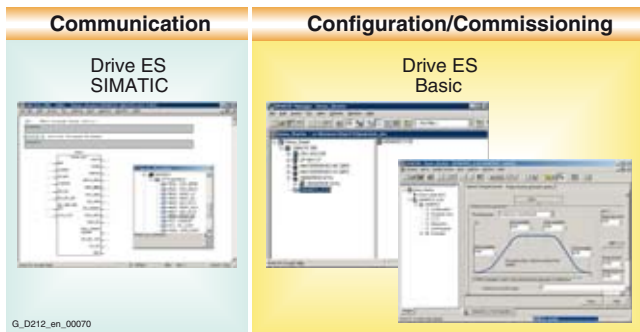

Drive ES is the engineering system used to integrate Siemens drive technology into the SIMATIC automation world easily, efficiently and cost-effectively in terms of communication, configuration and data management. The STEP 7 Manager user interface provides the basis for this procedure.

Various software packages are available for SINAMICS:

- Drive ES Basic**
for first-time users of the world of Totally Integrated Automation and the option for routing beyond network limits and the use of the SIMATIC teleservice.
Drive ES Basic is the basic software program for setting the parameters of all drives online and offline.
Drive ES Basic processes the automated system and drives on the interface of the SIMATIC Manager. Drive ES Basic is the starting point for common data archiving for complete projects and for extending the use of the SIMATIC teleservice to drives.
Drive ES Basic provides the engineering tools for the new motion control functions – peer-to-peer data traffic, equidistance and isochronous operation with PROFIBUS DP.
- Drive ES SIMATIC**
Simply parameterize the STEP 7 communication instead of programming.
In order to use Drive ES SIMATIC STEP 7 must be installed. It features a SIMATIC function block library, thereby making the programming of the PROFIBUS interface in the SIMATIC-CPU for the drives easy and secure.
There is no need for separate, time-consuming programming of the data exchange between the SIMATIC-CPU and the drive.
All Drive ES users need to remember is:
Copy – Modify – Load – Finished.
Customized, **fully-developed function blocks** are copied from the library into user-specific projects.
Frequently-used functions are set to run in program format:
 - Read out complete diagnostics buffer automatically from the drive
 - Complete parameter sets are automatically downloaded into the drive from the SIMATIC CPU – e.g. when a device has to be replaced.
 - Part parameter sets (e.g. for recipe and product change) are automatically downloaded into the drive from the SIMATIC-CPU
 - Complete parameterization or part parameter sets are uploaded from the drive into the SIMATIC-CPU, i.e. updated.
- Drive ES PCS 7**
integrates drives with the PROFIBUS interface into the SIMATIC PCS 7 process control system.
Drive ES PCS 7 can only be used with SIMATIC PCS 7 Version 5.2 and higher. Drive ES PCS 7 provides a function block library with function blocks for the drives and the corresponding faceplates for the operator station, which enables the drives to be operated from the PCS 7 process control system.

For further information please visit us on the Internet at:

<http://www.siemens.com/drivesolutions>

Selection and ordering data

	Order No.
Drive ES Basic V 5.4	
• Configuration software for the integration of drives into Totally Integrated Automation	
• Requirement: STEP 7 V 5.3 and higher, SP3	
• Supply format: on CD-ROM de, en, fr, es, it with electronic documentation	
Single license	6SW1700-5JA00-4AA0
Multi-user license, 60 pieces	6SW1700-5JA00-4AA1
Update service for single-user license	6SW1700-0JA00-0AB2
Update service for multi-user license	6SW1700-0JA00-1AB2
Upgrade from V 5.x to V 5.4	6SW1700-5JA00-4AA4
Drive ES SIMATIC V 5.4	
• Function block library for SIMATIC for the parameterization of communication with the drives	
• Requirement: STEP 7 V 5.3 and higher, SP3	
• Supply format: on CD-ROM de, en, fr, es, it with electronic documentation	
Single-user license incl. 1 x runtime license	6SW1700-5JC00-4AA0
Runtime license	6SW1700-5JC00-1AC0
Update service for single-user license	6SW1700-0JC00-0AB2
Upgrade from V 5.x to V 5.4	6SW1700-5JC00-4AA4
Drive ES PCS 7 V 6.1	
• Function block library for PCS 7 for the integration of drives	
• Requirement: PCS 7 V 6.1	
• Supply format: on CD-ROM de, en, fr, es, it with electronic documentation	
Single-user license incl. 1 x runtime license	6SW1700-6JD00-1AA0
Runtime license	6SW1700-5JD00-1AC0
Update service for single-user license	6SW1700-0JD00-0AB2
Upgrade from V 5.x to V 6.1	6SW1700-6JD00-1AA4

SINAMICS G110/SINAMICS G120

Engineering Tools

Notes

5

6

Services and Documentation

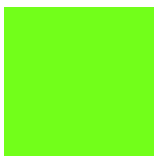

6/2	Training
6/2	Overview
6/3	Design
6/4	Function
6/5	Training case
6/5	SINAMICS G110 training case
6/5	SINAMICS G120 training case
6/6	Documentation
6/6	SINAMICS G110
6/6	SINAMICS G120
6/6	SINAMICS G120D
6/8	Replacement fans
6/8	SINAMICS G120
6/8	SINAMICS G120D
6/10	Service & Support

SINAMICS G110/SINAMICS G120

Services and documentation

Training

Overview



Training is decisive for your success

SITRAIN- Siemens Training for Automation and Industrial Solutions – provides you with comprehensive support in solving your tasks.

Training by the market leader in automation, plant installation and plant support enables you to make your decisions with certainty and full command. Especially where the optimum and efficient use of products and plants are concerned. You can eliminate deficiencies in existing plants and exclude expensive faulty planning right from the beginning.

All in all, this represents an enormous gain for your company: Shortened startup times, optimized plant components, faster troubleshooting, reduced down times. In other words, increased profits and lower costs.

Top trainers

Our trainers know their topics in practice and possess comprehensive didactic experience. Course developers have a direct wire to product development, and directly pass on their knowledge to the trainers.

Practical experience

The practical experience of our trainers enable them to pass on theoretical matter in a plausible manner. But since it is known that all theory is drab, we attach great importance to practical exercises which can comprise up to half of of the course time. You can therefore immediately implement your new knowledge in practice. We train you on state-of-the-art methodically/didactically designed training equipment. You feel absolutely certain when trained in this manner.

Wide variety

With a total of approx. 300 local attendance courses, we train the complete range of A&D products and a large portion of the system solutions from I&S. Telecourses, teach-yourself software and seminars presented on the Web supplement our classical range of courses.

Close to our customer

We are only a short distance away. You can find us approx. 60 times in Germany, and worldwide in 62 countries. You wish to have individual training instead of one of our 300 courses? Our solution: we will provide a program tailored exactly to your personal requirements. Training can be carried out in our Training Centers or at your company.

The right mixture: blended learning

Blended learning is understood to be the combination of various training media and sequences. For example, a local attendance course in a Training Center can be optimally supplemented by a teach-yourself program as preparation or follow-up. Furthermore, SITRAIN utilizes supported online training for live instruction on the Internet at agreed times.

The right mixture is the solution. Therefore blended learning can convey complex topics well and train networked thinking. Additional effect: reduced traveling costs and periods of absence through training sequences independent of location and time.

The international training portal

Additional information is available on the Internet at:

<http://www.siemens.com/sitrain>

All training facilities at a glance: search in the worldwide range of courses at leisure, call up all course dates online, utilize the daily updated display of vacant course spaces – and register directly.

Or let us advise you personally:

Course office, Infoline Germany
Tel.: +49-(0)1805-23 56 11
Fax: +49-(0)1805-23 56 12

... and request our latest training catalog on:

	Language	Order No.
ITC Catalog (paper version)	German	E86060-K6850-A101-B7
Dates and Price List including CD-ROM	German	E86060-P6850-A101-D3
SITRAINonCD interactive course information system on CD-ROM	German/ English	E86060-D6850-A100-C5-7400

Design

Training package

The courses are modular in design and are intended for a variety of target groups as well as individual customer requirements. An overview course enables decision-makers and sales personnel to get to know the SINAMICS drive family as well as its positioning in the existing Siemens drive environment.

SITRAIN offers a compact course for users of SINAMICS G110. Due to the uniform parametrization and commissioning of MICROMASTER 4 and SINAMICS G110, both technologies can well be combined in one course.

A training course on the subject of service and commissioning provides the necessary depth of technical knowledge for SINAMICS G120 and SINAMICS G120D.

SINAMICS G120 is also covered by various courses which deal more generally with the SINAMICS drive system.

All modules contain as many practical exercises as possible in order to enable intensive and direct training on the drive system and with the tools in small groups.



Title	Target group					Duration	Course code
	Decision-makers, sales personnel	Programmers	Commissioning engineers, configurators	Service personnel	Maintenance personnel		
SINAMICS system overview	✓	–	–	–	–	2 days	DR-SN-UEB
MICROMASTER MM4/SINAMICS G110	–	–	✓	✓	✓	1 day	SD-WSMM4
SINAMICS G120 commissioning and service	✓	–	✓	✓	✓	2 days	DR-G120-EXP
SINAMICS communication	–	✓	✓	✓	–	3 days	DR-SN-COM

SINAMICS G110/SINAMICS G120

Services and documentation

Training

Function

SINAMICS system overview (2 days) *DR-SN-UEB*

Description/learning target

This course has been specially designed for sales personnel and decision-makers who wish to attain a rapid overview of the SINAMICS drive concept and its position in the existing Siemens drive environment.

The system overview is supplemented by an introduction to the fundamentals of motor and inverter technology.

The SIZER configuration tool and the STARTER commissioning tool are presented and explained using short exercises.

Target group

Decision-makers and sales personnel

Content

- SINAMICS system overview
- Position with respect to existing drive systems
- Fundamentals of converter engineering and motors
- SIZER configuration tool
- STARTER commissioning tool
- Simple commissioning of a drive
- Practical exercises using the training case

MICROMASTER MM4/SINAMICS G110 compact course (1 day) *SD-WSMM4*

Description/learning target

This introductory course is designed for consultant engineers, configurators, maintenance personnel, technical sales personnel, service engineers and commissioning engineers. Previous knowledge with respect to drives is not required since basics concerning drives are taught. Standard functions of MICROMASTER 410, 420, 430, 440 as well as basic functions of the drive SINAMICS G110 are addressed.

Theoretical knowledge is already put to practice during the course and, thus, is strengthened.

We recommend the course SD-MM4-AUF to acquire advanced knowledge and to learn about controlling special functions/special applications.

Target group

Commissioning engineers, configurators, service personnel, maintenance personnel

Content

- Basics of inverter technology, difference to line-fed operation
- Product overview MICROMASTER 4, SINAMICS G110
- Commissioning with Basic Operator Panel BOP
- Commissioning with PC tool STARTER via USS interface and PROFIBUS
- Digital and analog inputs and outputs
- Control word, status word
- U/f characteristic curve and vector control
- Flexible signal interconnection with BICO technology
- Inverter functions (flying restart, braking resistor, DC brake, PID controller, etc.)

SINAMICS G120 commissioning and service (2 days) *DR-G120-EXP*

Description/learning target

This course addresses the configuration and first commissioning of the SINAMICS G120 drive system. Practical exercises with the SINAMICS G120 training case are an important component.

After finishing the course, you will be comfortable dealing with the STARTER commissioning tool. Consequently, the various inverter functions can be applied efficiently.

Target group

Decision-makers, sales personnel, commissioning engineers, configurators, servicing and maintenance personnel

Content

- Design of the SINAMICS G120 drive system
- Commissioning and parameterization with the STARTER commissioning tool
- Inverter functions (flying restart, braking, closed-loop control)
- Data storage
- Flexible signal interconnection with BICO technology
- Safety Integrated functions
- Diagnostics and troubleshooting
- Practical exercises using the training case

SINAMICS communication (3 days) *DR-SN-COM*

Description/learning target

The course is appropriate for programmers and service engineers who, as an extension to the DR-SNS-SI course, require further knowledge of the PROFIBUS and RS232 communications interfaces for STARTER and AOP30, as well as I/O terminals.

The focal point is PROFIBUS with the PROFIDrive V3 profile with routing, teleservice, and the functionalities associated with the equidistant bus cycle, isochronous mode with servo applications, and direct OP access. Also described are the libraries of DriveES SIMATIC for cyclic and acyclic data exchange.

This knowledge is expanded by practical exercises using SINAMICS and SIMATIC S7 training cases with CPU 315-2 DP.

Target group

Commissioning engineers, configurators, service engineers

Content

- PROFIBUS fundamentals
- Basic functions and drive-specific PROFIBUS data of usage
- Alignment of the SIMATIC-S7 project with the integrated STARTER project with respect to expanded standard lengths and contents of telegrams
- Isochronous mode and equidistance in the SIMATIC-S7 project
- Cyclic and acyclic data exchange with Drive ES SIMATIC components
- Operating the drive via PROFIBUS signals, speed-controlled and in positioning mode
- PROFIBUS-routing via MPI and ethernet TCP/IP
- Configuration of the PROFINET module CBE20 in the STARTER project
- Integration of the SINAMICS S120 drive into the SIMATIC-S7-PROFINET project
- Practical exercises with the training cases

SINAMICS G110/SINAMICS G120

Services and documentation

SINAMICS G110 training case

Overview



The modular SIDEMO case system for micro-systems also includes a training case for SINAMICS G110 which is designed for mobile use for sales and servicing.

The training case is equipped with an analog version of a SINAMICS G110 inverter.

The training case can be operated on its own or together with training systems such as LOGO!, SIMATIC S7-200, and SITOP DC-USV.

For this reason, a conversion guide is enclosed with the training case that enables the user to replace the inverter with a USS version (not included in the scope of supply).

The training systems are fitted in dark blue transport cases (400 x 300 x 210 mm; gross weight: 12 kg). The transport cases can be stacked.

Further information is available on the Internet at <http://www.siemens.de/sidemo>

Selection and ordering data

	Order No.
SINAMICS G110 training case (incl. BOP operator panel)	6AG1064-1AA03-0AA0
Line adapter 110 V/230 V	6AG1064-1AA02-0AA0

SINAMICS G120 training case

Application



A training case has been developed for on-site training and demonstration of the SINAMICS G120 system. It can demonstrate and increase understanding of a wide range of SINAMICS G120 functions. The case uses the CU240S DP-F as a Control Unit with which the PROFIBUS interface and safety functions can be demonstrated.

Design

- Drive system comprising:
 - CU240S DP-F Control Unit
 - Power Module PM240 frame size FSA, 0.37 kW
 - Basic operator panel (BOP)
 - Asynchronous motor 1LA7060-4AB10
 - Encoder
 - Load equipment
- Control station with toggle switches and potentiometers
- Power cable, PROFIBUS cable
- Storage and carrying case (Tanos box made of hard plastic)

The training case is supplied ready for use. As an option, the case can be supplied with a Zarges box (robust hard shell case).

Technical specifications

Input voltage	230 V 1 AC
Degree of protection to DIN VDE 0470 Part 1, EN 60529, IEC 529	IP00
Ambient temperature, perm.	
• Storage and transport	-20 ... +60 °C
• Operation	5 ... 40 °C
Dimensions	
• Width	540 mm
• Height	500 mm
• Depth	400 mm
Weight, approx.	13 kg

Selection and ordering data

	Order No.
SINAMICS G120 training case with <u>Tanos box</u>	6ZB2480-0CD00
SINAMICS G120 training case with <u>Zarges box</u>	6ZB2480-0CD00-Z A01
Line adapter 110 V/230 V	6AG1064-1AA02-0AA0

SINAMICS G110/SINAMICS G120

Services and documentation

Documentation

Übersicht

SINAMICS G110

The following manuals are available for the inverter chassis units SINAMICS G110:

	Manuals		
	Operation instructions	Parameter list	Getting started guide
Controlled Power Module			
CPM110	de, en, fr, it, es	de, en, fr, it, es	multilingual

Manuals are available in the following form:

Paper documentation

The scope of supply for each Controlled Power Module comprises a Getting started guide in hard copy form. Additionally, the Operating instructions and the Parameter list can be ordered in hard copy form.

Online version on the Internet as download

The documentation is also available on the Internet under

<http://www.siemens.com/sinamics-g110>

SINAMICS G120

SINAMICS G120 is a modular inverter system that comprises different function units – these are primarily the Control Unit and the Power Module. The documentation is also organized in a modular structure. The following manuals are available:

	Manuals			
	Installation guide	Operating instructions	List manual	Getting started
Control Unit				
CU240S	–	de, en	de, en	multilingual
Power Modules				
PM240	de, en	–	– ¹⁾	multilingual
PM250	de, en	–	– ¹⁾	multilingual
PM260	de, en	–	– ¹⁾	multilingual

Manuals are available in the following form:

Multi Language Package on CD-ROM (available soon)

A multi-language package on CD-ROM is supplied with every Control Unit which comprises all manuals in the available languages for SINAMICS G120.

Paper documentation

A Getting started guide is supplied in hard copy form with every Power Module and Control Unit.

Online version on the Internet as download

The documentation is also available on the Internet under

<http://www.siemens.com/sinamics-g120>

SINAMICS G120D

SINAMICS G120D is a modular, distributed inverter system that comprises different function units – these are primarily the Control Unit and the Power Module. The documentation is also organized in a modular structure. The following manuals are available:

	Manuals			
	Installation guide	Operating instructions	List manuals	Getting started
Control Unit				
CU250D	–	de, en	de, en	multilingual
Power Module				
PM250D	de, en	–	– ¹⁾	multilingual

The documentation is also available on the Internet under

Multi Language Package on CD-ROM

A multi-language package on CD-ROM is supplied with every Control Unit which comprises all manuals in the available languages for SINAMICS G120D.

Paper documentation

A Getting started guide is supplied in hard copy form with every Power Module and Control Unit.

Online version on the Internet as download

The documentation is also available on the Internet under

<http://www.siemens.com/sinamics-g120d>

¹⁾ The parameter settings for the Power Modules are included in the List manual for the Control Units.

SINAMICS G110/SINAMICS G120

Services and documentation

Documentation

Selection and ordering data

Type of documentation	Language	Order No.
SINAMICS G110 Operating instructions (Paper version)	de	6SL3298-0AA11-0AP0
	en	6SL3298-0AA11-0BP0
	fr	6SL3298-0AA11-0DP0
	it	6SL3298-0AA11-0CP0
	es	6SL3298-0AA11-0EP0
SINAMICS G110 Parameter list (Paper version)	de	6SL3298-0BA11-0AP0
	en	6SL3298-0BA11-0BP0
	fr	6SL3298-0BA11-0DP0
	it	6SL3298-0BA11-0CP0
	es	6SL3298-0BA11-0EP0

Further information

Language	Manual in language
de	German
en	English
fr	French
it	Italian
es	Spanish
multilingual	de, en, fr, it, es

Installation manual

The Installation manual describes the actions that have to be carried out once with or on the product in order to use the product in the desired place in the desired way. The Installation manual contains all relevant information for setting up, assembling and wiring as well as the required dimension drawings and circuit diagrams.

Usage phases: Installation and commissioning phase

Operating instructions

Operating instructions are a comprehensive collection of all information necessary for the normal and safe operation of products, process cells and complete plants (EN 62079).

Usage phases: Planning and configuration phase, implementation phase, setup and commissioning phase, application phase, maintenance and service phase.

List manual/Parameter list

The List manual and/or the Parameter list describe all parameters, function charts and faults/warning for the product/system as well as their meanings and setting options. It contains parameter data and fault/warning descriptions with functional correlations.

Usage phases: Commissioning of components that have already been connected, configuration of system functions and fault cause/diagnostics.

Getting started/Getting started guide

The Getting started and the Getting started guide provide information about getting started for the first-time user as well as references to additional information. It contains information about basic steps to be taken during commissioning. Descriptions of more advanced procedures can be found in the other documentation.

Usage phases: Commissioning of components that have already been connected.

SINAMICS G120

Services and documentation

Replacement fans for SINAMICS G120

Overview

The Power Module fans are designed for extra long service life. Replacement fans can be ordered for special applications.

Selection and ordering data

Rated output		SINAMICS G120 Power Module PM240		Replacement fan
kW	hp	Typ 6SL3224-...	Frame size and number of fans	Order No.
380 ... 480 V 3 AC				
0.37	0.50	0BE13-7UA0	FSA, 1 fan	6SL3200-0SF01-0AA0 (includes 1 replacement fan)
0.55	0.75	0BE15-5UA0		
0.75	1.0	0BE17-5UA0		
1.1	1.5	0BE21-1UA0		
1.5	2	0BE21-5UA0		
2.2	3	0BE22-2 . A0	FSB, 2 fans ¹⁾	
3.0	4	0BE23-0 . A0		6SL3200-0SF03-0AA0 (includes 1 replacement fan)
4.0	5	0BE24-0 . A0		
7.5	10	0BE25-5 . A0	FSC, 2 fans ¹⁾	
11.0	15	0BE27-5 . A0		6SL3200-0SF04-0AA0 (includes 2 replacement fans)
15.0	20	0BE31-1 . A0		
18.5	25	0BE31-5 . A0	FSD, 2 fans	6SL3200-0SF05-0AA0 (includes 2 replacement fans)
22	30	0BE31-8 . A0		
30	40	0BE32-2 . A0		6SL3200-0SF04-0AA0 (includes 2 replacement fans)
37	50	0BE33-0 . A0	FSE, 2 fans	
45	60	0BE33-7 . A0		6SL3200-0SF05-0AA0 (includes 2 replacement fans)
55	75	0BE34-5 . A0	FSF, 2 fans	
75	100	0BE35-5 . A0		6SL3200-0SF06-0AA0 (includes 2 replacement fans)
90	125	0BE37-5 . A0		
				6SL3200-0SF07-0AA0 (includes 2 replacement fans)

¹⁾ Recommendation: Even if only one fan on the Power Module is defective, it is advisable to replace both. In this case, the order quantity must be doubled.

SINAMICS G120

Services and documentation

Replacement fans for SINAMICS G120

Selection and ordering data (continued)

Rated output		SINAMICS G120 Power Module PM250		Replacement fan
kW	hp	Type 6SL3225-...	Frame size and number of fans	Order No.
380 ... 480 V 3 AC				
7.5	10	0BE25-5AA0	FSC, 2 fans ¹⁾	6SL3200-0SF03-0AA0 (includes 1 replacement fan)
11.0	15	0BE27-5AA0		
15.0	20	0BE31-1AA0		
18.5	25	0BE31-5AA0	FSD, 2 fans	6SL3200-0SF04-0AA0 (includes 2 replacement fans)
22	30	0BE31-8AA0		
30	40	0BE32-2AA0		6SL3200-0SF05-0AA0 (includes 2 replacement fans)
37	50	0BE33-0AA0	FSE, 2 fans	6SL3200-0SF04-0AA0 (includes 2 replacement fans)
45	60	0BE33-7AA0		6SL3200-0SF05-0AA0 (includes 2 replacement fans)
55	75	0BE34-5AA0	FSF, 2 fans	6SL3200-0SF06-0AA0 (includes 2 replacement fans)
75	100	0BE35-5AA0		
90	125	0BE37-5AA0		6SL3200-0SF08-0AA0 (includes 2 replacement fans)

Rated output		SINAMICS G120 Power Module PM260		Replacement fan
kW	hp	Type 6SL3225-...	Frame size and number of fans	Order No.
660 ... 690 V 3 AC				
11,0	15	0BH27-5 . A0	FSD, 2 fans	6SL3200-0SF05-0AA0 (includes 2 replacement fans)
15,0	20	0BH31-1 . A0		
18,5	25	0BH31-5 . A0		
30	40	0BH32-2 . A0	FSF, 2 fans	6SL3200-0SF07-0AA0 (includes 2 replacement fans)
37	50	0BH33-0 . A0		
55	75	0BH33-7 . A0		

Replacement fan for SINAMICS G120D

Selection and ordering data

Rated output		SINAMICS G120D Power Module PM250D		Replacement fan
kW	hp	Type 6SL3525-...	Frame size	Order No.
660 V ... 690 V 3 AC				
4.0	5.0	OPE24-0AA0	FSC	6SL3500-0SF01-0AA0 (preassembled unit with cover, fan and screws)
5.5	7.5	OPE25-5AA0		
7.5	10	OPE27-5AA0		

¹⁾ Recommendation: Even if only one fan on the Power Module is defective, it is advisable to replace both. In this case, the order quantity must be doubled.

SINAMICS G110/SINAMICS G120

Appendix

Customer Support Our Services for Every Phase of Your Project

Overview



In the face of harsh competition you need optimum conditions to keep ahead all the time: a strong starting position, a sophisticated strategy and team for the necessary support – in every phase.

Service & Support from Siemens provides this support with a complete range of different services for automation and drives.

In every phase: from planning and commissioning to maintenance and upgrading.

Our specialists know when and where to act to keep the productivity and cost-effectiveness of your system running in top form.

Online support



The comprehensive information system available round the clock via Internet ranging from Product Support and Service & Support services to Support Tools in the Shop.

<http://www.siemens.com/automation/service&support>

Technical support



Competent consulting in technical questions covering a wide range of customer-oriented services for all our products and systems.

Phone: +49 (0)180 50 50 222
Fax: +49 (0)180 50 50 223

E-Mail: adsupport@siemens.com

In the United States, call toll-free:

Phone: +1 800 333 7421
Fax: +1 423 262 2200

E-Mail: solutions.support@sea.siemens.com

In Canada, call:

Phone: +1 888 303 3353
E-Mail: cic@siemens.ca

In Asia:

Phone: +86 10 6475 7575
Fax: +86 10 6474 7474

E-Mail: adsupport.asia@siemens.com

Technical consulting

Support in the planning and designing of your project from detailed actual-state analysis, target definition and consulting on product and system questions right to the creation of the automation solution. ¹⁾

Configuration and software engineering

Support in configuring and developing with customer-oriented services from actual configuration to implementation of the automation project. ¹⁾

Service on site



With service on site we offer services for startup and maintenance, essential for ensuring system availability.

In Germany
Phone: +49 (0)180 50 50 444 ¹⁾

In the United States, call toll-free:

Phone: +1 800 333 7421

In Canada, call:

Phone: +1 888 303 3353

Repairs and spare parts



In the operating phase of a machine or automation system we provide a comprehensive repair and spare parts service ensuring the highest degree of operating safety and reliability.

In Germany
Phone: +49 (0)180 50 50 448 ¹⁾

In the United States, call toll-free:

Phone: +1 800 241 4453

In Canada, call:

Phone: +1 888 303 3353

Optimization and upgrading



To enhance productivity and save costs in your project we offer high-quality services in optimization and upgrading. ¹⁾

SPARESonWeb – online spare parts catalog



SPARESonWeb is a web-based tool for selecting the spare parts available for the SINAMICS system. After you have registered and entered the serial number and order number, the spare parts available for the relevant unit are displayed.

The delivery state for specific orders can be displayed for all shipped SINAMICS products.

<http://workplace.automation.siemens.com/sparesonweb>

¹⁾ For country-specific telephone numbers go to our Internet site at: <http://www.siemens.com/automation/service&support>

Appendix



- 7/2** Frequency inverters for SIMATIC ET 200 distributed I/O
- 7/4** Siemens contacts worldwide
- 7/5** **A&D online services – Information and ordering on the Internet and on CD-ROM**
 - 7/5 A&D in the WWW
 - 7/5 Product selection using the Offline Mall of Automation and Drives
 - 7/5 Easy shopping with the A&D Mall
- 7/6** Subject index
- 7/7** Order number index
- 7/8** Conditions of sale and delivery, Export regulations



SINAMICS G110/SINAMICS G120

Appendix

Frequency inverters for SIMATIC ET 200 distributed I/O

Frequency inverters are available for the SIMATIC ET 200 distributed I/O that are fully system-integrated modules. Inverters are available for the finely modular SIMATIC ET 200S FC system to the IP20 degree of protection as well as for the cabinet-free SIMATIC ET 200pro FC system to the IP65 degree of protection. With a broad range of possibilities, the frequency inverters expand the functional scope of the modular modules that are available in both systems (e.g. inputs and outputs, technology modules, direct and soft starters). With suitable interface modules, connection to PROFIBUS and PROFINET is possible via the ET 200 system bus as well as integration of PLC functionality into the system. Fail-safe frequency inverter functions can be activated locally or via PROFI-safe.

An overview of the features of these frequency inverters is given in the tables below. The complete product spectrum including ordering data, technical data and explanations can be found in Catalog IK PI "Industrial Communication for Automation und Drives" (SIMATIC ET 200pro FC will be available soon) and on the Internet at

<http://www.siemens.com/et200s-fc>

and

<http://www.siemens.com/et200pro-fc>

SIMATIC ET 200S FC

Main features	<ul style="list-style-type: none"> • Complete embedding of a frequency inverter into a distributed I/O system to IP20 degree of protection • Easy assembly and low susceptibility to errors thanks to self-assembling energy and communications bus • Space-saving assembly thanks to compact dimensions and common protection • Fast, tool-free replacement of the frequency inverter for a servicing requirement (hot swapping) • Frequency control (V/f), vector control with and without encoders • Line-commutated regenerative feedback by power electronics of the latest generation • Modular structure with Control Unit (closed-loop control module) and Power Module (power section) • Frequency inverter variant with integrated, autonomous, fail-safe functions without the need for complex external wiring
Rated outputs	0.75 kW, 2.2 kW, 4.0 kW
Input voltage	380 ... 480 V 3 AC ±10%
Overall width	Control Unit + Power Module up to 0.75 kW: 80 mm, otherwise 145 mm
Mains frequency	47 ... 63 Hz
Overload capability	<ul style="list-style-type: none"> • Overload current 1.5 × rated output current (i.e. 150% overload) over 60 s, cycle time 300 s • Overload current 2 × rated output current (i.e. 200% overload) over 3 s, cycle time 300 s
Output frequency	0 ... 650 Hz
Pulse frequency	8 kHz (standard), 2 ... 16 kHz (in steps of 2 kHz)
Frequency bands that can be skipped	1, programmable
Efficiency	≥ 96%
Interfaces	<ul style="list-style-type: none"> • Connection to PROFIBUS via IM151 interface module • Connection to PROFINET via IM151-3PN interface module • Integration of PLC functionality through IM151 CPU and IM151-7 F CPU interface modules • RS232 interface with USS protocol for commissioning on the PC with the STARTER commissioning software • Slot for an optional Micro Memory Card for uploading or downloading parameter settings • PTC/KTY84 interface for motor monitoring • Speed sensor interface (Sub-D connector) for unipolar HTL incremental encoder • Activation of the integrated safety functions over PROFI-safe (using the PM-D F PROFI-safe Power Module) or terminals (using the Safety Local Power Module PM-D F X1)
Standards conformance	UL, cUL, CE and c-tick, Low-Voltage Directive 73/23/EEC, EMC Directive 89/336/EEC
Functional safety	<p>Closed-loop control module with Integral safety functions to Category 3 of EN 954-1 and SIL2 of IEC 61508:</p> <ul style="list-style-type: none"> • Safety torque off • Safely limited speed • Safe stop 1 <p>The safety functions "Safely limited speed" and "Safe stop 1" are certified for encoderless asynchronous motors. These safety functions are not approved for pull-through loads as in the case of lifting gear and winders</p>
Degree of protection	IP20

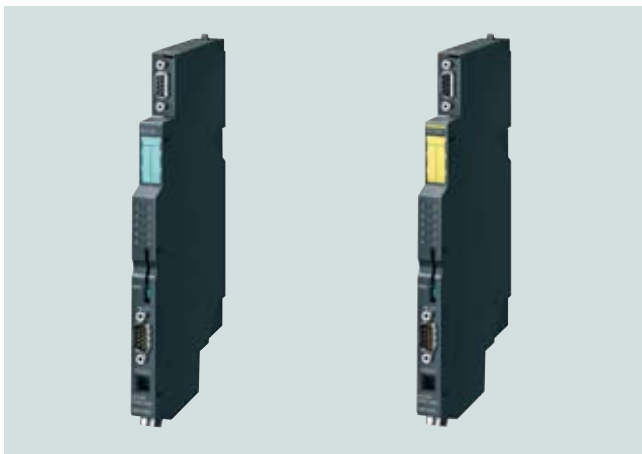

SIMATIC ET 200S FC
Control Units



SIMATIC ET 200S FC
Power Modules

SIMATIC ET 200pro FC

Main features	<ul style="list-style-type: none"> • Complete embedding of a frequency inverter into a distributed I/O system to IP65 degree of protection • Easy assembly and low susceptibility to errors thanks to self-assembling energy and communications bus • Fast replacement of the frequency inverter during servicing without interruption of the bus communication to other modules within the SIMATIC ET 200pro FC • Frequency control (V/f), vector control without encoders • Line-commutated regenerative feedback by power electronics of the latest generation • Frequency inverter variant with integrated, autonomous, fail-safe functions without the need for complex external wiring
Rated outputs	1.1 kW (at 0 ... 55 °C ambient temperature) 1.5 kW (at 0 ... 45 °C ambient temperature)
Input voltage	380 ... 480 V 3 AC ±10%
Overall width	155 mm
Mains frequency	47 ... 63 Hz
Overload capability	<ul style="list-style-type: none"> • Overload current 1.5 × rated output current (i.e. 150% overload) over 60 s, cycle time 300 s • Overload current 2 × rated output current (i.e. 200% overload) over 3 s, cycle time 300 s
Output frequency	0 ... 650 Hz
Pulse frequency	4 kHz (standard) 2 ... 16 kHz (in steps of 2 kHz)
Frequency bands that can be skipped	1, programmable
Efficiency	≥ 96%
Interfaces	<ul style="list-style-type: none"> • Connection to PROFIBUS through IM154-1 and IM154-2 interface modules • Available soon connection to PROFINET over IM154-4PN interface modules and connection to IM154-8 CPU interface modules • Optical interface with USS protocol for fiber-optic RS232 connecting cable • Control signal for 200 V DC electromagnetic motor brake • Slot for an optional memory card (MMC) for uploading or downloading parameter settings • PTC/KTY84 interface for motor temperature monitoring • Activation of the integrated safety functions through the Safety Local Isolator Module F RSM
Standards conformance	UL, cUL, CE and c-tick, Low-Voltage Directive 73/23/EEC, EMC Directive 89/336/EEC
Functional safety	<p>Variant with Integral safety functions to Category 3 of EN 954-1 and SIL2 of IEC 61508:</p> <ul style="list-style-type: none"> • Safety torque off • Safely limited speed • Safe stop 1 <p>The safety functions "Safely limited speed" and "Safe stop 1" are certified for encoderless asynchronous motors. These safety functions are not approved for pull-through loads as in the case of lifting gear and winders</p>
Degree of protection	IP65



SIMATIC ET 200pro FC
Standard frequency inverter



SIMATIC ET 200pro FC Failsafe
Frequency inverter with integrated safety functions

SINAMICS G110/SINAMICS G120

Appendix

Siemens contacts worldwide

SIEMENS

Local Partners Worldwide

Are you looking for a local contact to help you with questions regarding Siemens Automation and Drive products, solutions and services?

O.K. First, please select the city nearest to your location:

* (or to select a different country click here)

Berlin

Now select the appropriate team who you would like to deal with your enquiry:

Sales

Next >

© 2007 Siemens, Automation and Drive
www.siemens.com/automation/partner

SIEMENS

Local Partners Worldwide

Please select a sector:

Select area/sector Select city Your contact(s)

Sectors Search a Sector

Which sector* is your question regarding?

Add Sectors

- Drive Systems, Automation Systems
- Electrical Infrastructure
- Material Flow Controlling, Distribution and Logistics
- Assembly Control
- Paper Machines
- Production Automation in the Automotive Industry and Suppliers
- Production Logistics and Control Systems
- Production Machines, Textiles, Plastics, Metal Forming, Wood, Glass, Ceramic processing, Stone processing, Packaging, Printing, Cranes
- Process Control Systems
- Textile/Fiber Assembly

* This list contains industry sectors covered by Siemens Automation and Drive products and solutions.

Please select the team who you would like to deal with your enquiry:

Sales

Next >

© 2007 Siemens, Automation and Drive
www.siemens.com/automation/partner

SIEMENS

Local Partners Worldwide

Please select a Siemens product group:

Select area/product Select city Your contact(s)

Product Catalog Search a Product

Which product* does your question refer to?

- Drive Technology
- Automation systems
- Communication/Informatics
- Low-voltage Control
- Electrical Installation Technology
- Process Automation
- Sensor, measuring and testing technology
- Power supplies
- Safety systems - Safety integrated
- System solutions and products for branches

* This list contains products and solutions provided by Siemens Automation and Drive.

Please select the team who you would like to deal with your enquiry:

Sales

Next >

© 2007 Siemens, Automation and Drive
www.siemens.com/automation/partner

At

<http://www.siemens.com/automation/partner>

you can find details of Siemens contact partners worldwide responsible for particular technologies.

You can obtain in most cases a contact partner for

- Technical Support,
- Spare parts/repairs,
- Service,
- Training,
- Sales or
- Consultation/engineering.

You start by selecting a

- Country,
- Product or
- Sector.

By further specifying the remaining criteria you will find exactly the right contact partner with his/her respective expertise.

A&D in the WWW



A detailed knowledge of the range of products and services available is essential when planning and configuring automation systems. It goes without saying that this information must always be fully up-to-date.

The Siemens Automation and Drives Group (A&D) has therefore built up a comprehensive range of information in the World Wide Web, which offers quick and easy access to all data required.

Under the address

<http://www.siemens.com/automation>

you will find everything you need to know about products, systems and services.

Product selection using the Offline Mall of Automation and Drives

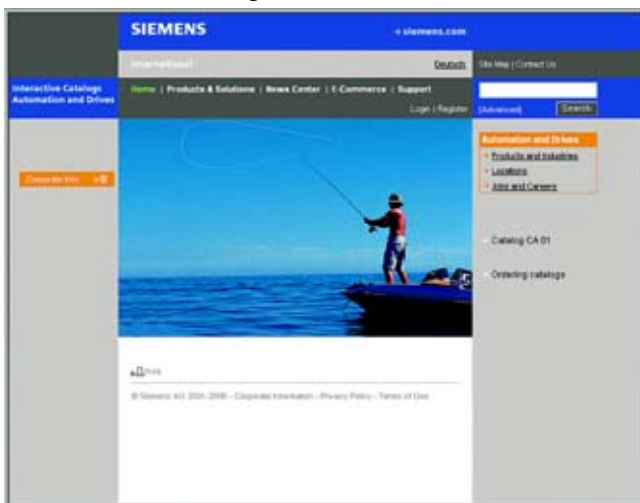

Detailed information together with convenient interactive functions:

The Offline Mall CA 01 covers more than 80,000 products and thus provides a full summary of the Siemens Automation and Drives product base.

Here you will find everything that you need to solve tasks in the fields of automation, switchgear, installation and drives. All information is linked into a user interface which is easy to work with and intuitive.

After selecting the product of your choice you can order at the press of a button, by fax or by online link.

Information on the Offline Mall CA 01 can be found in the Internet under

<http://www.siemens.com/automation/ca01>

or on CD-ROM or DVD.

Easy shopping with the A&D Mall



The A&D Mall is the virtual department store of Siemens AG in the Internet. Here you have access to a huge range of products presented in electronic catalogs in an informative and attractive way.

Data transfer via EDIFACT allows the whole procedure from selection through ordering to tracking of the order to be carried out online via the Internet.

Numerous functions are available to support you.

For example, powerful search functions make it easy to find the required products, which can be immediately checked for availability. Customer-specific discounts and preparation of quotes can be carried out online as well as order tracking and tracing.

Please visit the A&D Mall on the Internet under:

<http://www.siemens.com/automation/mall>

SINAMICS G110/SINAMICS G120

Appendix

Subject index

	Part/Page		Part/Page
A		I	
Accessories		Integrated EMC filter SINAMICS G110	2/13
SINAMICS G110	2/9	Integration	
SINAMICS G120	3/51	SINAMICS G120 PM240	3/17
SINAMICS G120D	4/7, 4/10	SINAMICS G120 PM250	3/32
Adapter for DIN rail attachment	3/67	SINAMICS G120 PM260	3/44
Additional EMC filter, class B	2/13	Inverter chassis units	
Application		SINAMICS G110	2
SINAMICS G110	2/3	SINAMICS G120	3
SINAMICS G120	3/3		
SINAMICS G120D	4/3	L	
B		Line reactor	
Basic Operator Panel (BOP)		SINAMICS G110	2/13
SINAMICS G110	2/9	SINAMICS G120	3/52
SINAMICS G120	3/64	Line filter SINAMICS G120	3/50
Benefits		Line-side power components	
SINAMICS G110	2/2	SINAMICS G110	2/14
SINAMICS G120	3/3	SINAMICS G120	3/55
SINAMICS G120D	4/3	M	
Brake Relay SINAMICS G120	3/65	Memory card for Control Units	3/15
Braking resistors SINAMICS G120	3/57	MMC memory card	3/15
C		N	
Characteristic curves (derating data)		NEMA1 mounting kit SINAMICS G120	3/68
SINAMICS G120 PM240	3/25	O	
SINAMICS G120 PM250	3/39	Output reactors SINAMICS G120	3/59
SINAMICS G120 PM260	3/48	Overview	
SINAMICS G120D PM250D	4/15	SINAMICS G110	2/2
Circuit diagrams SINAMICS G110	2/11	SINAMICS G120	3/2
Configuration		SINAMICS G120D	4/2
SINAMICS G120	3/5	P	
SINAMICS G120D	4/4	PC inverter connection kit SINAMICS G120	3/64
Connection diagram		Power Modules	
CU240	3/9	PM240	3/16
PM240	3/17	PM250	3/31
PM250	3/32	PM260	3/43
PM260	3/44	R	
Control Units CU240	3/7	Replacement fan	
Control Unit CU240D	4/7	SINAMICS G120	6/8
Controlled Power Modules	2/8	SINAMICS G120D	6/9
D		S	
Derating data		Safe Brake Relay SINAMICS G120	3/66
SINAMICS G110	2/5	Safety Integrated	3/3
SINAMICS G120 PM240	3/25	SD configurator	5/2
SINAMICS G120 PM250	3/39	Selection and ordering data	
SINAMICS G120 PM260	3/48	SINAMICS G110	2/8
SINAMICS G120D PM250D	4/15	SINAMICS G120 CU240	3/7
Design		SINAMICS G120 PM240	3/24
SINAMICS G110	2/3	SINAMICS G120 PM250	3/38
SINAMICS G120	3/4	SINAMICS G120 PM260	3/48
SINAMICS G120D	4/3	SINAMICS G120D CU240D	4/7
Dimensional drawings		SINAMICS G120D PM250D	4/10
SINAMICS G110	2/10	Shield connection kit SINAMICS G120	3/67
SINAMICS G120 PM240	3/26	SINAMICS G110	2
SINAMICS G120 PM250	3/40	SINAMICS G120	3
SINAMICS G120 PM260	3/49	SINAMICS G120D	4
SINAMICS G120D PM250D	4/16	SIZER	5/3
Distributed frequency inverters SINAMICS G120D	4	Standards conformance SINAMICS G110	2/6
Documentation	6/6	STARTER	5/4
Drive ES	5/5	Starter kit SINAMICS G110	2/12
E		T	
Electromagnetic compatibility	2/7	Technical specifications	
EMC filter, class B SINAMICS G110	2/13	SINAMICS G110	2/4
Engineering Tools	5	SINAMICS G120	3/6
F		SINAMICS G120D	4/5
Frequency inverter, distributed SINAMICS G120D	4	Training	6/2
Function SINAMICS G110	2/3	Training case	6/5

			Order number index		
		Part/Page			Part/Page
3NA			6SL		
3NA3...	Fuse	2/14, 3/55, 3/56	6SL3224-OBE...	Power Module PM240 SINAMICS G120	3/23
3NE			6SL3224-OBH...	Power Module PM260 SINAMICS G120	3/48
3NE1...	Fuse	3/55, 3/56	6SL3225-OBE...	Power Module PM250 SINAMICS G120	3/38
3RK			6SL3244-OBA2...	Control Unit SINAMICS G120	3/7
3RK1911-2BE..	Connector set for line supply SINAMICS G120D	4/10	6SL3252-0BB00-0AA0	Brake Relay for SINAMICS G120	3/65
3RK1922-2BP00	RS232 interface cable for SINAMICS G120D	4/7	6SL3252-0BB01-0AA0	Safe Brake Relay for SINAMICS G120	3/66
3RV			6SL3254-0AM00-0AA0	MMC memory card	3/15, 4/7
3RV10...	Circuit-breaker	2/14, 3/55, 3/56	6SL3255-0AA00-2AA1	PC inverter connection kit for SINAMICS G120	3/64
3VL			6SL3255-0AA00-2AA1	PC inverter connection kit for SINAMICS G110	2/9
3VL...	Circuit-breaker	3/55, 3/56	6SL3255-0AA00-4BA1	Basic Operator Panel BOP for SINAMICS G120	3/64
6AG			6SL3255-0AA00-4BA1	Operator panel BOP for SINAMICS G110	2/9
6AG1064-1AA02-0AA0	Line adapter SINAMICS G110	6/5	6SL3261-1B...	Adapter for DIN rail attachment for SINAMICS G110	2/9
6AG1064-1AA03-0AA0	SINAMICS G110 training case	6/5	6SL3262-1A...	Shield connection kit for SINAMICS G120	3/67
6ES			6SL3262-1B...	Adapter for DIN rail attachment for SINAMICS G120	3/67
6ES7194-1AB01-0XA0	Connector set for motor cable for SINAMICS G120D	4/10	6SL3262-1C...	NEMA1 mounting kit SINAMICS G120	3/68
6ES7194-1L...	preassembled motor cable for SINAMICS G120D	4/10	6SL3262-1F...	Shield connection kit for SINAMICS G120	3/67
6SE			6SL3271-0CA00-0AG0	Documentation CD for SINAMICS G110	2/9
6SE6400-2FA00-6AD0	Line filter class A for SINAMICS G120	3/51	6SL3298-0...	Documentation for SINAMICS G110	6/7
6SE6400-2FB00-6AD0	Line filter class B for SINAMICS G120	3/51	6SL3500-0SF01-0AA0	Replacement fan for SINAMICS G120D	6/9
6SE6400-2FLO...	Filter class B with low leakage currents for SINAMICS G110	2/14	6SL3500-OSK01-0AA0	Spare parts kit for SINAMICS G120D	4/7
6SE6400-2FS0...	Additional EMC filter, class B for SINAMICS G110	2/14	6SL3525-OPE...	Power Module SINAMICS G120D	4/10
6SE6400-3CC...	Line reactor	2/14, 3/54	6SL3544-OFA2...	Control Unit SINAMICS G120D	4/7
6SE6400-3TC...	Output reactor for SINAMICS G120	3/63			
6SE6400-4BD...	Braking resistor for SINAMICS G120	3/58			
6SL			6SW		
6SL3070-0AA00-0AG0	SIZER	5/3	6SW1700-...	Drive ES	5/5
6SL3072-0AA00-0AG0	STARTER	2/9, 5/4			
6SL3200-0AB10-0AA0	Starter kit SINAMICS G110	2/12	6ZB		
6SL3200-0SF0...	Replacement fan for SINAMICS G120	6/8, 6/9	6ZB2480-0CD00	Training case SINAMICS G120	6/5
6SL3201-0BE12-0AA0	Braking resistor for SINAMICS G120	3/58	E86060		
6SL3202-0A...	Output reactor for SINAMICS G120	3/63	E86060-D4001-A...	Interactive catalog CA 01	5/2
6SL3203-0B...	Line filter class B for SINAMICS G120	3/50	E86060-D6850-A100-C5-7400	SITRAIN course infor- mation system	6/2
6SL3203-0C...	Line reactor for SINAMICS G120	3/54	E86060-K6850-A101-B7	Catalog ITC	6/2
6SL3211-0AB...	Inverter chassis units SINAMICS G110	2/8	E86060-P6850-A101-D3	Dates and price list SITRAIN	6/2

SINAMICS G110/SINAMICS G120

Appendix

Conditions of sale and delivery Export regulations

Terms and Conditions of Sale and Delivery

By using this catalog you can acquire hardware and software products described therein from Siemens AG subject to the following terms. Please note! The scope, the quality and the conditions for supplies and services, including software products, by any Siemens entity having a registered office outside of Germany, shall be subject exclusively to the General Terms and Conditions of the respective Siemens entity. The following terms apply exclusively for orders placed with Siemens AG.

For customers with a seat or registered office in Germany

The "General Terms of Payment" as well as the "General Conditions for the Supply of Products and Services of the Electrical and Electronics Industry" shall apply.

For software products, the "General License Conditions for Software Products for Automation and Drives for Customers with a Seat or registered Office in Germany" shall apply.

For customers with a seat or registered office outside of Germany

The "General Terms of Payment" as well as the "General Conditions for Supplies of Siemens Automation and Drives for Customers with a Seat or registered Office outside of Germany" shall apply.

For software products, the "General License Conditions for Software Products for Automation and Drives for Customers with a Seat or registered Office outside of Germany" shall apply.

General

The dimensions are in mm. In Germany, according to the German law on units in measuring technology, data in inches only apply to devices for export.

Illustrations are not binding.

Insofar as there are no remarks on the corresponding pages, - especially with regard to data, dimensions and weights given - these are subject to change without prior notice.

The prices are in € (Euro) ex works, exclusive packaging.

The sales tax (value added tax) is not included in the prices. It shall be debited separately at the respective rate according to the applicable legal regulations.

Prices are subject to change without prior notice. We will debit the prices valid at the time of delivery.

Surcharges will be added to the prices of products that contain silver, copper, aluminum, lead and/or gold if the respective basic official prices for these metals are exceeded. These surcharges will be determined based on the official price and the metal factor of the respective product.

The surcharge will be calculated on the basis of the official price on the day prior to receipt of the order or prior to the release order.

The metal factor determines the official price as of which the metal surcharges are charged and the calculation method used. The metal factor, provided it is relevant, is included with the price information of the respective products.

An exact explanation of the metal factor and the text of the Comprehensive Terms and Conditions of Sale and Delivery are available free of charge from your local Siemens business office under the following Order Nos.:

- 6ZB5310-0KR30-0BA1
(for customers based in Germany)
- 6ZB5310-0KS53-0BA1
(for customers based outside Germany)

or download them from the Internet
<http://www.siemens.com/automation/mall>
(Germany: A&D Mall Online-Help System)

Export regulations

The products listed in this catalog / price list may be subject to European / German and/or US export regulations.

Therefore, any export requiring a license is subject to approval by the competent authorities.

According to current provisions, the following export regulations must be observed with respect to the products featured in this catalog / price list:

AL	<p>Number of the <u>German Export List</u></p> <p>Products marked other than "N" require an export license.</p> <p>In the case of software products, the export designations of the relevant data medium must also be generally adhered to.</p> <p>Goods labeled with an "<u>AL</u>" <u>not equal to "N"</u> are subject to a European or German export authorization when being exported out of the EU.</p>
ECCN	<p><u>Export Control Classification Number</u></p> <p>Products marked other than "N" are subject to a reexport license to specific countries.</p> <p>In the case of software products, the export designations of the relevant data medium must also be generally adhered to.</p> <p>Goods labeled with an "<u>ECCN</u>" <u>not equal to "N"</u> are subject to a US re-export authorization.</p>

Even without a label or with an "AL: N" or "ECCN: N", authorization may be required due to the final destination and purpose for which the goods are to be used.

The deciding factors are the AL or ECCN export authorization indicated on order confirmations, delivery notes and invoices.

Errors excepted and subject to change without prior notice.

A&D/VuL_ohne MZ/En 05.09.06

Catalogs of the Automation and Drives Group (A&D)

Further information can be obtained from our branch offices listed in the appendix or at www.siemens.com/automation/partner

Automation and Drives	<i>Catalog</i>		
Interactive catalog on CD-ROM and on DVD			
• The Offline Mall of Automation and Drives	CA 01		
Automation Systems for Machine Tools			
SINUMERIK & SIMODRIVE	NC 60		
SINUMERIK & SINAMICS	NC 61		
Drive Systems			
<u>Variable-Speed Drives</u>			
SINAMICS G130 Drive Converter Chassis Units, SINAMICS G150 Drive Converter Cabinet Units	D 11		
SINAMICS G110 Inverter Chassis Units	D 11.1		
SINAMICS GM150/SINAMICS SM150 Medium-Voltage Converters	D 12		
SINAMICS S120 Drive Converter Systems	D 21.1		
SINAMICS S150 Drive Converter Cabinet Units	D 21.3		
Asynchronous Motors Standardline	D 86.1		
Synchronous Motors with Permanent-Magnet Technology, HT-direct	D 86.2		
DC Motors	DA 12		
SIMOREG DC MASTER 6RA70 Digital Chassis Converters	DA 21.1		
SIMOREG K 6RA22 Analog Chassis Converters	DA 21.2		
SIMOREG DC MASTER 6RM70 Digital Converter Cabinet Units	DA 22		
SIMOVERT PM Modular Converter Systems	DA 45		
SIEMOSYN Motors	DA 48		
MICROMASTER 410/420/430/440 Inverters	DA 51.2		
MICROMASTER 411/COMBIMASTER 411	DA 51.3		
SIMOVERT MASTERDRIVES Vector Control	DA 65.10		
SIMOVERT MASTERDRIVES Motion Control	DA 65.11		
Synchronous and asynchronous servomotors for SIMOVERT MASTERDRIVES	DA 65.3		
SIMODRIVE 611 universal and POSMO	DA 65.4		
<u>Low-Voltage Three-Phase-Motors</u>			
IEC Squirrel-Cage Motors	D 81.1		
<u>Automation Systems for Machine Tools SIMODRIVE</u>	NC 60		
• Main Spindle/Feed Motors			
• Converter Systems SIMODRIVE 611/POSMO			
<u>Automation Systems for Machine Tools SINAMICS</u>	NC 61		
• Main Spindle/Feed Motors			
• Drive System SINAMICS S120			
<u>Drive and Control Components for Hoisting Equipment</u>	HE 1		
Electrical Installation Technology			
<i>PDF: ALPHA Small Distribution Boards and Distribution Boards, Terminal Blocks</i>	ETA 1		
<i>PDF: ALPHA 8HP Molded-Plastic Distribution System</i>	ETA 3		
<i>PDF: BETA Low-Voltage Circuit Protection</i>	ET B1		
<i>PDF: DELTA Switches and Socket Outlets</i>	ET D1		
GAMMA Building Controls	ET G1		
Human Machine Interface Systems SIMATIC HMI	ST 80		
Industrial Communication for Automation and Drives		<i>Catalog</i>	IK PI
Low-Voltage			
Controls and Distribution – SIRIUS, SENTRON, SIVACON		LV 1	
Controls and Distribution – Technical Information SIRIUS, SENTRON, SIVACON		LV 1 T	
SIDAC Reactors and Filters		LV 60	
SIVENT Fans		LV 65	
SIVACON 8PS Busbar Trunking Systems		LV 70	
Motion Control System SIMOTION			PM 10
Process Instrumentation and Analytics			
Field Instruments for Process Automation		FI 01	
Measuring Instruments for Pressure, Differential Pressure, Flow, Level and Temperature, Positioners and Liquid Meters			
<i>PDF: Indicators for panel mounting</i>		MP 12	
SIREC Recorders and Accessories		MP 20	
SIPART, Controllers and Software		MP 31	
SIWAREX Weighing Systems		WT 01	
Continuous Weighing and Process Protection		WT 02	
Process Analytical Instruments		PA 01	
<i>PDF: Process Analytics, Components for the System Integration</i>		PA 11	
SIMATIC Industrial Automation Systems			
SIMATIC PCS Process Control System		ST 45	
Products for Totally Integrated Automation and Micro Automation		ST 70	
SIMATIC PCS 7 Process Control System		ST PCS 7	
Add-ons for the SIMATIC PCS 7 Process Control System		ST PCS 7.1	
Migration solutions with the SIMATIC PCS 7 Process Control System		ST PCS 7.2	
pc-based Automation		ST PC	
SIMATIC Control Systems		ST DA	
SIMATIC Sensors			
Sensors for Factory Automation		FS 10	
SIPOS Electric Actuators			
Electric Rotary, Linear and Part-turn Actuators		MP 35	
Electric Rotary Actuators for Nuclear Plants		MP 35.1/.2	
Systems Engineering			
Power supplies SITOP power		KT 10.1	
System cabling SIMATIC TOP connect		KT 10.2	
System Solutions			
Applications and Products for Industry are part of the interactive catalog CA 01			
TELEPERM M Process Control System			
<i>PDF: AS 488/TM automation systems</i>			PLT 112

PDF: These catalogs are only available as pdf files.

www.siemens.com/sinamics

Siemens AG

Automation and Drives
Standard Drives
Postfach 31 80
91050 ERLANGEN
Germany

www.siemens.com/automation

The information provided in this catalog contains descriptions or characteristics of performance which in case of actual use do not always apply as described or which may change as a result of further development of the products. An obligation to provide the respective characteristics shall only exist if expressly agreed in the terms of contract. Availability and technical specifications are subject to change without notice.

All product designations may be trademarks or product names of Siemens AG or supplier companies whose use by third parties for their own purposes could violate the rights of the owners.

Order No. E86060-K5511-A111-A4-7600

SIEMENS

SINAMICS G110 • SINAMICS G120D

SINAMICS G120 • SINAMICS G120D

SINAMICS G110 • SINAMICS G120

SINAMICS G110 • SINAMICS G120

SINAMICS G110 • SINAMICS G120

SINAMICS G110 • SINAMICS G120

CATALOG

D 11.1 • 2007

Catalog D 11.1 • 2007

Catalog D 11.1 • 2007

Catalog D 11.1 • 2007

Catalog D 11.1 • 2007

Catalog D 11.1 • 2007

emera AG 2